

West Africa Regional Scientific Observer Training Manual



Compiled by K.S. Dietrich for ICCAT Fisheries Capacity Building Fund in collaboration with Teresa Turk¹, Kate Wynne² and Manjula Tiwari³

¹Division of International Affairs, NOAA Fisheries, Silver Spring, MD USA

²University of Alaska Fairbanks, Alaska Sea Grant Marine Advisory Program, Kodiak, AK USA

³Marine Turtle Ecology & Assessment Program, Protected Resources Division, NOAA Fisheries, LaJolla, CA USA

Contents

BACKGROUND

Acknowledgements.....	vii
1 Introduction.....	1-1
1.1 Learning objectives	1-1
1.2 Manual Organization.....	1-1
1.3 Overview of MCS	1-1
1.3.1 What is MCS?.....	1-1
1.3.2 Why have MCS?.....	1-2
1.3.3 How is data utilized?.....	1-2
1.4 Global fisheries – Gear, Issues & Management Instruments	1-3
1.4.1 Commercial fishing gear.....	1-3
1.4.2 Issues.....	1-3
1.4.3 International Management Instruments	1-4
1.5 Regional Fisheries Bodies	1-5
2 Scientific Observer Program – Objectives, Rights and Responsibilities.....	2-7
2.1 Learning objectives	2-7
2.2 Introduction	2-7
2.3 SOP Goal & Objectives.....	2-7
2.4 Rights and Responsibilities	2-8
2.4.1 Management Agency Responsibilities.....	2-8
2.4.2 Vessel Rights and Responsibilities	2-8
2.4.3 Observer Rights and Responsibilities	2-9
2.5 Observer Sampling Priorities, Duties and Required Skills	2-10
2.5.1 Code of conduct	2-12
3 Essential Information	3-1
3.1 Learning Objectives	3-1
3.2 Introduction	3-1
3.3 Data collection overview.....	3-1
3.4 Observer Logbook.....	3-2
3.4.1 Calculations.....	3-2
3.4.2 Rounding Rules.....	3-2
3.5 Life at Sea Basics	3-3
3.5.1 Living Conditions	3-3
3.5.2 Nautical terminology	3-3
3.5.3 Communication.....	3-4
3.5.4 Navigation.....	3-6
3.6 Fundamental statistical concepts.....	3-8
3.6.1 What is a “statistically representative sample”?	3-8
3.6.2 Why is random sampling important?.....	3-8
3.6.3 Steps in Taking a Random Sample	3-9
3.6.4 Random Systematic Sampling	3-10
3.6.5 Sample Bias	3-10
3.7 First day(s) on board	3-11
4 Vessel and Trip Information	4-1
4.1 Learning objectives	4-1

4.2	Introduction	4-1
4.3	List of Priorities.....	4-1
4.4	Forms/Instructions.....	4-1
4.4.1	Vessel Information.....	4-1
4.4.2	Trip Summary	4-11
5	Catch Composition Form.....	5-1
5.1	Learning objectives	5-1
5.2	Introduction	5-1
5.3	List of Priorities.....	5-1
5.4	Forms/Instructions.....	5-1
5.4.1	Catch Composition Form.....	5-1
6	Trawl – Finfish.....	6-1
6.1	Learning objectives	6-1
6.2	Introduction	6-1
6.3	List of Priorities.....	6-1
6.4	Gear Description	6-1
6.5	Forms/Instructions.....	6-4
6.5.1	Gear Description – Finfish Trawl	6-4
6.5.2	Trawl Effort / Total Catch Form.....	6-14
6.6	Total Catch Estimation.....	6-17
6.6.1	Methods of Total Catch Weight Estimation	6-17
6.7	Catch Composition Sampling	6-23
6.7.1	Diversity of Fleet and Effects on Sampling.....	6-23
6.7.2	Haul Selection.....	6-25
6.8	Biological Data.....	6-26
7	Trawl – Shrimp	7-1
7.1	Learning objectives	7-1
7.2	Introduction	7-1
7.3	List of Priorities.....	7-1
7.4	Gear description	7-1
7.5	Forms/Instructions.....	7-4
7.5.1	Gear Description – Shrimp Trawl.....	7-4
7.5.2	Trawl Effort / Total Catch Form.....	7-12
7.6	Catch Composition Sampling	7-12
7.7	Biological Data.....	7-12
8	Pelagic Longline	8-13
8.1	Learning objectives	8-13
8.2	Introduction	8-13
8.3	List of Priorities.....	8-13
8.4	Gear Description	8-13
8.5	Fishing Description	8-16
8.6	Forms/Instructions.....	8-17
8.6.1	Gear Description Form – Pelagic Longline	8-17
8.6.2	Set and Haul Information Form	8-21
8.6.3	Catch Composition Sampling	8-28
8.7	Catch Composition and Biological Data	8-32
9	Purse Seine – Large Pelagics	9-1
9.1	Learning objectives	9-1
9.2	Introduction	9-1

9.3	List of Priorities.....	9-1
9.4	Gear Description	9-2
9.5	Fishing Description	9-4
9.6	Forms/Instructions.....	9-5
9.6.1	Gear Description Form	9-5
9.6.2	Daily Activity Log	9-9
9.6.3	Floating Object Record	9-17
9.6.4	Set Information & Catch Composition Form	9-22
9.7	Total Catch Estimation.....	9-27
9.8	Catch Composition Sampling	9-27
9.9	Biological Data.....	9-28
10	Biological Data & Specimen Collection.....	10-1
10.1	Learning objectives.....	10-1
10.2	Introduction	10-1
10.3	List of Priorities	10-1
10.4	Length Measurements.....	10-1
10.4.1	Fish (bony & cartilaginous)	10-2
10.4.2	Invertebrates.....	10-11
10.5	Additional Collections	10-16
10.5.1	Collection of whole fish / invertebrates	10-16
10.5.2	Tagged Animals	10-17
10.6	Species Identification	10-19
10.7	Fish and Invertebrate Forms/Instructions	10-21
10.7.1	Fish / Invertebrate Length Frequencies.....	10-21
10.7.2	Specimen Collection	10-23
10.7.3	Tag Encounter and Recovery	10-25
10.7.4	Species Identification forms	10-27
11	Marine Mammals, Sea Turtles & Seabirds – Catch, Sightings & Interactions.....	11-1
11.1	Learning objectives.....	11-1
11.2	Introduction	11-1
11.3	List of Priorities	11-1
11.3.1	Marine Mammals	11-1
11.3.2	Sea Turtles	11-1
11.3.3	Seabirds.....	11-6
11.4	Forms/Instructions	11-6
11.4.1	Marine Mammal and Turtle Sighting and Interaction Form.....	11-6
11.4.2	Marine Mammal Carcass Examination Form	11-16
11.4.3	Sea Turtle Capture form.....	11-20
11.4.4	Seabird Species Identification Form.....	11-29
12	Regulations and Compliance Monitoring	12-1
12.1	Learning objectives.....	12-1
12.2	Introduction	12-1
12.2.1	Observe	12-1
12.2.2	Inform	12-1
12.2.3	Document.....	12-2
12.3	Summary of Regulations	12-3
12.4	Forms/Instructions	12-4
12.4.1	Observer Logbook	12-4
12.4.2	Compliance Checklist	12-4

13	Surveillance.....	13-1
13.1	Learning objectives.....	13-1
13.2	Introduction	13-1
13.3	IUU Fishing – What is it?.....	13-1
13.4	List of Priorities	13-3
13.5	Forms/Instructions	13-3
13.5.1	Vessel and Aircraft Sightings	13-3
14	Marine Debris	14-1
14.1	Learning Objectives.....	14-1
14.2	Introduction	14-1
14.3	List of Priorities	14-1
14.4	Forms/Instructions	14-1
14.4.1	Marine Debris Encounter	14-1
15	Health & Safety Information	15-1
15.1	Learning objectives.....	15-1
15.2	Introduction	15-1
15.3	List of Priorities	15-1
15.4	Your Safety Responsibilities	15-1
15.5	Vessel Hazards	15-2
15.5.1	Safety on deck.....	15-2
15.5.2	Boarding vessels	15-3
15.5.3	Vessel transfers	15-4
15.5.4	Bacteria and Fungus.....	15-4
15.5.5	Heavy lifting and repetitive motion issues.....	15-5
15.5.6	Radar	15-5
15.6	Personal health & safety	15-5
15.6.1	Hydration	15-6
15.6.2	Hyperthermia & Hypothermia	15-7
15.6.3	Fatigue and sleep deprivation	15-7
15.6.4	Noise	15-7
15.6.5	Seasickness	15-7
15.6.6	Harassment.....	15-8
15.7	Survival at Sea	15-12
15.7.1	Life saving equipment.....	15-12
15.8	Seven Steps to Survival	15-18
15.9	Types of emergencies	15-19
15.9.1	Person Overboard.....	15-20
15.9.2	Fire	15-20
15.9.3	Flooding	15-21
15.9.4	Abandon Ship.....	15-22
15.10	Psychology of Survival.....	15-23
15.11	Forms/Instructions	15-23
15.11.1	Safety Checklist.....	15-23
16	References.....	16-1
17	Index	17-1
Appendix 1.	Country-Specific Information	17-3
Appendix 2.	Country-Specific Contacts	17-3
Appendix 3.	Country-Specific Vessel Names / Codes	17-3
Appendix 4.	List of Known IUU Vessels	17-4

Appendix 5.	Country & IRCS Codes.....	17-6
Appendix 6.	Fishing Gear Codes	17-8
Appendix 7.	Species Names and Codes.....	17-10
Appendix 8.	International and National Fishing Boundaries – Gulf of Guinea	17-60
Appendix 9.	Map of African Time Zones.....	17-61
Appendix 10.	Common Formulas & Conversion Factors	17-62
Appendix 11.	Random Number Tables.....	17-64
Appendix 12.	Sea State	17-66
Appendix 13.	Standard Phonetic Alphabet.....	17-67
Appendix 14.	International Conventions Signed by West African Nations	17-68
Appendix 15.	CITES Listed Marine Vertebrates – Southern & West Africa.....	17-70
Appendix 16.	Glossary.....	17-72

Acknowledgements

The following sources were invaluable during the development of this manual: (FAO 2002), (Davies and Reynolds 2002), (Van Helvoort 1986), (Hanrahan et al. 1997), (AMSEA 2006), the Western and Central Pacific Fisheries Commission Regional Observer Programme (forms online), and FAO/GEF shrimp trawl bycatch reduction project forms for Cameroon (supplied by Dr. Oumarou Njifondjou).

Shrimp trawl sampling protocols were greatly enhanced by the participation of George Chiambeng (Fisheries and Oceanographic Research Station, Limbé, Cameroon) during at-sea trials in November 2009.

Our deepest appreciation goes to the following organizations and people who provided copies of observer manuals and training materials and answered an endless list of questions:

- Alaska Marine Safety Education Association, USA - Jerry Dzugan
- CapFish, South Africa – Chris Heineken
- Department of Fisheries and Oceans, Newfoundland, Canada - Todd Inkpen
- Inter-American Tropical Tuna Commission - Ernesto Altamirano
- Institute for Research and Development (IRD), France - Daniel Gaertner, Pierre Chavance
- International Monitoring, Control and Surveillance Network - Marcel Kroese
- Secretariat of the Pacific Community - Deirdre Brogan and Tim Lawson
- Ministry of Fisheries and Marine Resources, Namibia - E.C. Kruger
- Muni-Pomadze Ramsar Site, Ghana - Andrews Agyekumhene
- Pacific Islands Regional Observer Program, USA - Stuart Arceneaux
- Southeast Shrimp and Reef Fish Observer Program, Galveston, USA - Elizabeth Scott-Denton, James Nance, and Mike Harrelson
- West Coast Groundfish Observer Program, Seattle, USA - Janell Majewski, John LaFargue and John McVeigh
- WWF Responsible Fisheries Programme, South Africa – Samantha Petersen
- Ebol Rojas - Certified ICCAT - IOTC - CCSBT - CCAMLR Observer

Country-specific sections and substantial input submitted by the following:

Cameroon: Dr. Pierre Nolasque Meke Soung (Brigade of Control and Surveillance of Fishing Activities, Ministry of Livestocks, Fisheries and Animal Industries, Department of Fisheries and Aquaculture, Yaoundé) and Baba Malloum Ousman (Ministry of Livestocks, Fisheries and Animal Industries, Department of Fisheries and Aquaculture, Yaoundé)

Sierra Leone: Sheku Sei (Ministry of Fisheries and Marine Resources)

Funding for manual development was provided by ICCAT through the NOAA Fisheries Special U.S. Capacity Building Fund.

1 Introduction

1.1 Learning objectives

- Explain the linkages and separate tasks of Monitoring, Control and Surveillance.
- List three management issues facing global fisheries.

1.2 Manual Organization

The purpose of this **Scientific Observer Sampling Manual** is to have a resource for training and at-sea field deployment of scientific observers on commercial fishing vessels in the east Atlantic Ocean including the Gulf of Guinea (Figure 1-1). The manual contains four main sections focusing on background information (Chapters 1-3) and the different aspects of Monitoring, Control and Surveillance (Chapters 4-10, 12 and 15, and 13, respectively). Chapters are organized around specific gear types and target fisheries. Country-specific information developed by individual observer programs is included as in Appendices 1-3. There is an extensive index of topics and a glossary of terms and acronyms. Each chapter begins with explicit learning objectives for the chapter that parallel the training modules. The objectives are followed by a brief introduction, a list of sampling priorities (where appropriate) and form instructions.

WEST AFRICA



Figure 1-1 West Africa and the Gulf of Guinea.

1.3 Overview of MCS

1.3.1 What is MCS?

In the most basic form, monitoring, control and surveillance or MCS is an integrated information gathering, rule-making and enforcement system used to manage fisheries. Everett (2005-2009) and Flewwelling et al. (2002) define each component more specifically as follows:

- **Monitoring** consists of the collection, measurement and analysis of fishing activity. The monitoring component of MCS should receive, integrate and verify information from the licensing unit, sea-going units (sightings and inspections), observers, vessel monitoring systems (VMS) and satellite imagery, radar, port inspection, regular dockside monitoring of landings, fishing logbooks, production logbooks, and air sightings for vessel identification, activity and location. This information is primary data that fisheries managers use to arrive at management decisions. If this information is unavailable, inaccurate or incomplete, managers will be handicapped in developing and implementing management measures.
- **Control** involves the specification of the enforceable terms and conditions under which resources can be harvested. These specifications are normally contained in national fisheries legislation and other arrangements that might be nationally, sub-regionally, or regionally agreed. The legislation provides the basis for which fisheries management arrangements, via MCS, are implemented.
- **Surveillance** involves the regulation and supervision of fishing activity to ensure that national legislation, conditions of access, and management measures are observed. The surveillance component of MCS will require fisheries personnel who not only collect data for the monitoring aspect of MCS during their surveillance duties, but can also communicate with and educate stakeholders involved in participatory conservation activities. These personnel must have the appropriate equipment and facilities, operating funds and training both to encourage voluntary compliance and to enforce laws where necessary. Surveillance is usually the largest and most expensive component to fund. This activity is critical to ensure that resources are not over exploited, poaching is minimized and management arrangements are implemented.

MCS has land, sea and air components. The land component entails port inspections, dockside monitoring, and the monitoring of transshipments and trade in fish products to ensure compliance with relevant rules. The sea component patrols national waters, employs no-force methods such as on board observers and technology (radar, sonar). The aerial component patrols using aircraft or satellite technology (e.g., VMS).

MCS utilizes both preventive and deterrent approaches to regulatory compliance. Preventive approaches enhance awareness by disseminating information to the fishers and the public to educate them on the rules or other issues. The deterrent approach implements fines or revokes fishing privileges if the rules are not followed.

1.3.2 Why have MCS?

The goal of fisheries management is to maximize the economic opportunities and benefits from a State's waters within sustainable harvesting limits (Flewellling et al. 2002). Various management schemes have been applied in different fisheries, but most are based on limiting entry licenses and include vessel and gear restrictions. Regardless of the management scheme, this goal cannot be achieved without MCS.

1.3.3 How is data utilized?

Data collected through MCS are utilized for stock assessment (e.g., how many fish can be removed safely while maintaining a healthy stock), fisheries management (e.g., decisions made to balance biological needs of the stock and economic and social needs of the humans dependent on the stock) and enforcement (e.g., the intervention of the government to control a fishery; (Davies and Lesch 1998, Wallace and Fletcher 2000, Cooper 2006)).

Each of these user groups has different information needs. For instance, stock assessment modelers may require total catch estimates by species (weight and numbers), length-weight or length-age relationships of catch and size at maturity (to determine breeding grounds and timing, recruitment) depending on the model used.

1.4 Global fisheries – Gear, Issues & Management Instruments

1.4.1 Commercial fishing gear

Commercial fishing gear can be categorized as either passive whereby fish move to the gear (e.g., longline, traps, gillnet) or active where gear moves to the fish (e.g., trawl, purse seine). There are more than 60 gear types classified by the International Standard Statistical Classification of Fishing Gear (Appendix 6); however, the majority of global catch is taken by five gear types: purse seine, mid-water trawl, bottom trawl, gillnet and hook and line (based on 1950-2001 data; Watson et al. 2006). In general, purse seine nets catch fish by surrounding fish from all sides as well as underneath. Both mid-water and bottom trawl nets are towed nets consisting of a wide opening with wings that herd fish into a cone-shaped body and are collected in the terminal end or codend. Gillnets consist of a wall of nearly invisible net in which fish become gilled or entangled. Hook and line gear consists of natural or artificial bait placed on a hook fixed to the end of a line. Hook and line gear can be configured with a single hook up to tens of thousands of hooks (Nedelec and Prado 1990).

1.4.2 Issues

The primary issues constraining global marine capture fisheries in the last decade and facing fisheries in the future include:

1. **Illegal, Unreported and Unregulated (IUU)** fishing constitutes a serious threat to: (i) fisheries, especially those of high-value that are already overfished (e.g. cod, tuna, redfish and swordfish); (ii) marine habitats, including vulnerable marine ecosystems; and (iii) food security and the economies of developing countries (FAO 2009b). IUU is considered an environmental crime involving theft of resources. There is an international initiative in progress to implement binding port state measures. IUU is discussed in more detail in Chapter 13;
2. **Bycatch and discards** can have significant consequences for populations, food webs and ecosystems. The most recent estimate of annual global discards was 7.3 million tons (1992-2001; (Kelleher 2005)). Several international initiatives (e.g., the development of International Plans of Action or IPOAs) focused on reducing the catch of specific taxonomic groups have been successful in raising awareness of the issue and reducing global catch. Bycatch reduction devices (BRDs) are discussed further in Chapters 6-7;
3. **Overfishing and overcapacity** of fishing fleets (Beddington et al. 2007);
4. **Trade and trade subsidies** as they relate to overfishing and overcapacity; and
5. **Climate change** impacts on fish distribution and the frequency of extreme weather events.

1.4.3 International Management Instruments

International law is the system of rules governing the relationship among States (and between States and international organizations). The rules of international law are reflected primarily in treaties which generally create obligations only for those States party to the treaty (i.e., treaties do not bind countries that did not sign the treaty). Other rules of international law arise from general international practice accepted as law (so-called “customary international law”), although it is sometimes difficult to determine whether a particular practice has become accepted as law by States.

Flewwelling et al. (2002) summarizes the major international laws and treaties pertaining to fisheries as follows:

1. The 1982 *United Nations Convention on the Law of the Sea* (UNCLOS), which entered into force in 1994, forms the backbone of the international legal framework for fisheries management. UNCLOS is the umbrella instrument to all of the others. It sets out the rights and duties of coastal, port and flag States in respect of each of the principal maritime zones recognized by international law. These zones include the territorial sea, the exclusive economic zone and the high seas. It also deals with a range of other important issues that are related, including the legal regimes applicable to internal waters, archipelagic waters, the contiguous zone, the continental shelf, and the right of innocent passage and passage through international straits.
2. The *FAO Compliance Agreement* (1994) seeks to strengthen the provisions in UNCLOS relating to high seas fishing. This treaty has two primary objectives: 1) to require all States whose vessels fish on the high seas to take a range of steps to ensure that those vessels do not undermine measures to conserve and manage the living resources of the high seas; and 2) to increase the transparency of all high seas fishing operations through the collection and dissemination of data.
3. The *FAO Code of Conduct for Responsible Fisheries* (CCRF; 1995) is a broad and comprehensive but non-binding document which prescribes principles and standards for the conservation and management of all fisheries, as well as for fish processing, trade in fish and fishery products, fishing operations, aquaculture, fisheries research and the integration of fisheries into coastal area management. A fundamental objective of CCRF is “to serve as an instrument of reference to help States to establish or to improve the legal and institutional framework required for the exercise of responsible fisheries and in the formulation and implementation of appropriate measures.”
4. The *UN Fish Stocks Agreement*, relating to the Conservation and Management of Straddling Fish Stocks and Highly Migratory Fish Stocks, sets forth a broad range of obligations designed to create greater control over fisheries for certain valuable stocks, including the strengthening of MCS capabilities. This treaty builds on several general provisions of UNCLOS in an effort to strengthen cooperation in the conservation and management of certain fish stocks that occur both within national Exclusive Economic Zones (EEZs) and on the high seas. Entered into force on 11 December 2001.
5. To date, four IPOAs have been developed within the framework of the Code of Conduct (CCRF). FAO adopted three of these instruments in 1999 to deal with the incidental catch of seabirds in longline fisheries, the conservation and management of sharks and the

management of fishing capacity. The fourth IPOA is designed to prevent, deter and eliminate illegal, unreported and unregulated (IUU) fishing.

6. *Convention on International Trade in Endangered Species of Wild Fauna and Flora*, or CITES, is an international agreement among governments to ensure that international trade in specimens of wild animals and plants does not threaten their survival. The Convention entered into force on 1 July 1975 and currently has a membership of 173 countries. Many marine mammal and all turtles are listed. Appendix 15 contains a more detailed list of marine species covered by CITES.

International law primarily regulates the relationship among States whereas domestic (or national) law regulates the relationships between persons (including legal persons such as companies) within a particular State. Domestic law extends to territorial waters (12 nmi), national EEZs (to 200 nmi) and continental shelf waters (when sedentary species extend beyond 200 nmi). Flag states are responsible for controlling the fishing activities of a vessel, no matter where the vessel operates (including the high seas).

1.5 Regional Fisheries Bodies

Regional Fishery Bodies (RFB) and Regional Fishery Management Organizations (RFMO) consist of groups of states or organizations that have agreed to a set of rules in order to work together towards the conservation and management of fish stocks. Six RFBs operate in the eastern central Atlantic. Each RFB focuses on a specific group of species (e.g. tuna) or covers multiple targets and fisheries on the high seas and within national waters. The coverage of several of these RFBs overlap (Figure 1-2).

The oldest and largest RFB in the Atlantic is the International Commission for the Conservation of Tuna (ICCAT). Data collected by observers on tuna vessels will be passed on to ICCAT for the management of tunas and tuna-like species.

Convention on the Conservation and Management of Fisheries Resources in the South East Atlantic Ocean established the Southeast Atlantic Fisheries Organization (SEAFO). This convention covers a sizeable part of the high seas of the South East Atlantic Ocean and includes sedentary / discrete and straddling species such as alfonso, orange roughy, oreo dories, armourhead, sharks, deepwater hake and red crab.

The Fishery Committee for the Eastern Central Atlantic (CECAF) covers a large portion of the Eastern Central Atlantic between Cape Sparte (Morocco) and the Congo River. The Committee covers all living marine resources within its area of competence. There are currently 34 member countries. Within the CECAF zone, there are three additional committees that include the national waters of the following countries:

- Sub-Regional Fisheries Commission (SRFC) - Cape Verde, Gambia, Guinea Bissau, Guinea, Mauritania, Senegal and Sierra Leone;
- Regional Fisheries Committee for the Gulf of Guinea (COREP) – Congo, Democratic Republic of Congo, Gabon, Sao Tome and Principe;
- Fishery Committee for the West Central Gulf of Guinea (FCWC) - Benin, Cote d'Ivoire, Ghana, Liberia, Nigeria and Togo.

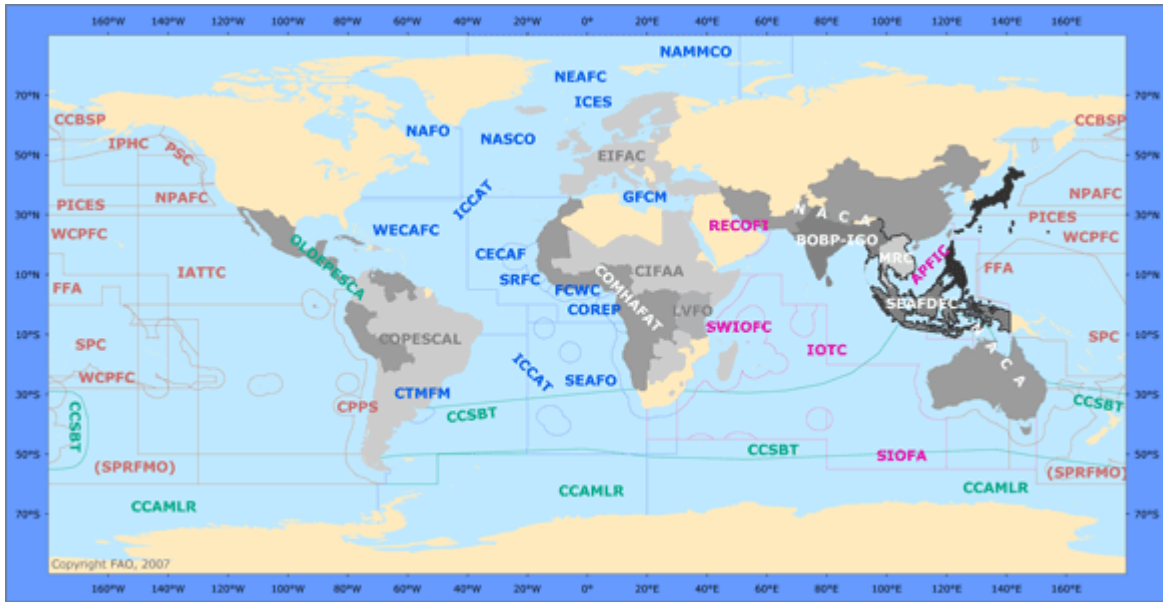

Figure 1-2 Approximate boundaries of Regional Fisheries Bodies (FAO 2001-2010).

2 Scientific Observer Program – Objectives, Rights and Responsibilities

2.1 Learning objectives

- Describe at least 5 objectives of Scientific Observer Programs
- Discuss the importance of professional conduct with industry and other personnel

2.2 Introduction

This chapter describes the goal and objectives of Scientific Observer Programs (SOPs). In order to achieve the goal and objectives, all stakeholders (i.e., government agencies, the fishing industry) have significant roles to play. This chapter explains in great detail the responsibilities and expectations of each group. Laubstein (1999), Davies and Reynolds (2002), WCPFC (2003), NWFSC (2006), AFSC (2007), Kranz (2007) and WCPFC (2009) were valuable resources when compiling the list of responsibilities and duties.

2.3 SOP Goal & Objectives

The overarching goal of an SOP is to collect independent, reliable and accurate data on fishing operations, catches and interactions with the environment by the vessel and its fishing gear to ensure long-term conservation and sustainable use of living aquatic resources and ecosystems in the east Atlantic Ocean. To achieve this goal, the SOP has the following specific objectives:

- Estimate total fishing effort (i.e., position, time, total catch) for all hauls;
- Estimate weight and/or numbers of all species caught (catch composition) and establish disposition (e.g., retained, discarded, dead or alive) on a subsample of hauls;
- Collect biological information (e.g. lengths) on target and non-target species on a subsample of hauls;
- Monitor fish or fish product offloads and transshipments;
- Monitor IUU activity;
- Document types of vessel equipment utilized (e.g. gear characteristics, electronics) and record vessel characteristics (e.g. registration numbers, licenses, etc);
- Collect catch and biological data on marine mammals and sea turtles (including sightings);
- Document the presence of marine debris.

Additional objectives, depending on the country, may include:

- Evaluate the effectiveness of bycatch reduction devices (BRDs; including turtle excluder devices or TEDs);
- Educate fishers regarding BRDs, careful release techniques for sea turtles, seabirds and marine mammals and other relevant rules/regulations;
- Collect economic data;
- Provide input to future regulatory changes utilizing observer data;
- Monitor fish quality.

2.4 Rights and Responsibilities

2.4.1 Management Agency Responsibilities

The agency controlling the SOP is responsible for the following:

- Set observer coverage levels for each fishery/gear type on an annual basis.
- Develop an observer placement plan (for fisheries with <100% coverage in the future) including how vessels will be selected, time observed, etc.
- Ensure that the vessel owners, permit holders and captains are fully aware of all fishing and observer requirements and obligations that the vessel may be under (including assessment of fees for observer coverage, safety, accommodation, etc). This can be accomplished during the permit process via a letter of intent explaining SOP objectives and/or meetings in ports with industry groups and individual fishers.
- Coordinate a briefing of the observer and the vessel captain before departure to review the obligations regarding the observer and vessel before the observer departs. This meeting should include a review of the observer data collection priorities and duties, observer and vessel responsibilities, adequate accommodation, vessel insurance, vessel compliance with required safety standards and review emergency procedures, access to bridge equipment needed to carry out observer duties (i.e. GPS, communications), ensure sampling area is safe, etc.
- Development of policies relating to the Observer Code of Conduct, and promote national regulations needed to avoid sampling interference or any other interference on the observer duties, and harassment on the part of the crew;
- Supply all relevant equipment and forms to the observer for carrying out their duties, including the collection of data and biological sampling;
- Inform observer about 1) trip requirements and expectations, 2) sampling regimes, 3) data collection priorities if different than manual, and 4) any alleged questionable issues recorded in previous observer trips on the same vessel;
- Assist with the procurement of observer visas, entry permits, waivers and any travel documents required to transport the observer to the departure or from arrival port of the vessel;
- Organize all travel arrangements including air, bus, or ferry as necessary;
- Coordinate communication schedule with the observers; and
- Establish data confidentiality policies.

2.4.2 Vessel Rights and Responsibilities

The rights of vessel captains and crew shall include:

- Expectation that a reasonable period of prior notice of the placement or replacement of an observer shall be given.
- Opportunity to review and comment on the observer's data forms, including the right to include additional information deemed relevant or a personal statement.
- Ability to conduct lawful fishing operations with minimum interference due to the observer's presence and performance of necessary duties.
- Reasonable expectation of privacy in crew personal areas.

The duties and responsibilities of vessel captains and crew shall include:

- Accepting an approved observer if required by the SOP.
- Inform the SOP 24 hours prior to landing or departing any port.

- Assisting the observer to safely embark and disembark the vessel at an agreed place and time.
- Assisting the observer to carry out all duties safely.
- Providing the observer with food, accommodations, medical facilities, and sanitary facilities of a reasonable standard equivalent to those normally available to an officer on board the vessel.
- Facilitating access by the observer to all areas and facilities of the vessel necessary to conduct observer duties, including the bridge, communications equipment and personnel, deck, and areas used to process, weigh, and store fish, gear, and equipment.
- Provide access to certificate of registry, safety certificate and navigation and fishing log.
- Permitting the observer to remove samples from the catch and providing appropriate storage space for specimens collected and retained by the observer.
- Ensuring actions and equipment are consistent with fishing regulations and permit conditions.
- Ensuring that captain or crew do not obstruct, intimidate, influence, or interfere with the observer or impede or delay observer duties. Observers may not act as vessel crew.

2.4.3 Observer Rights and Responsibilities

The observer's rights include:

- Access to all areas and facilities of the vessel necessary to conduct observer duties, including the bridge, deck, areas used to process, weigh, and store fish, gear, and equipment..
- Access to the vessel's records including its logs and documentation for the purpose of records inspection, access to navigational equipment, charts and radios, and reasonable access to other information relating to fishing.
- Access to and use of communications equipment and personnel, upon request, for entry, transmission, and receipt of work related data or information.
- Access to additional equipment, if present, to facilitate the work of the observer while on board the vessel, such as binoculars, electronic means of communication, etc.
- Access to the working deck during net or line retrieval and to specimens (alive or dead) in order to collect samples.
- Notice of at least fifteen (15) minutes before fish are brought on board, unless the observer specifically requests not to be notified.
- Access to food, accommodations, medical facilities, and sanitary facilities of a reasonable standard equivalent to those normally available to an officer on board the vessel.
- The provision of adequate space on the bridge or galley for clerical work and adequate space on the deck for observer duties.
- Freedom to carry out their duties without interference, intimidation, or obstruction.

The observer's responsibilities include:

- Acceptance and compliance with agreed confidentiality rules and procedures with respect to the fishing operations of the vessels. Data, images and other information collected by the observer shall remain confidential and should be handled in a secure manner.
- Maintenance of independence and impartiality at all times while on board the fishing vessel.
- Documenting compliance with the laws and regulations set by the managing agency.
- Respecting the hierarchy and general rules of behavior that apply to all vessel personnel.
- Performance of duties in a manner that minimizes interference with fishing operations.

- Achieve a basic familiarity with the emergency procedures aboard the vessel, including the locations of life rafts, fire extinguishers, and first aid kits.
- Communicating regularly with the vessel captain and maintain open communication with vessel personnel.
- Observers may be required to embark or disembark in another country. Before observer departs for a trip, the observer must possess a valid passport with at least 6 months before the expiration date. Observer will obtain relevant visas and immunizations.
- Observers will be required to be medically fit.
- Observers must be on board and ready to depart at least 1-hour prior to the agreed boarding date/time. All pre-trip requirements should be completed by this time.
- Communicate with observer program daily or on schedule requested by SOP.
- Maintain observer code of conduct (below).
- Collect data according to the protocols described in the SOP manual. Observers are accountable for all data, issued equipment, and manuals. Loss of data can be grounds for dismissal.
- Data entry of during off-vessel time.

2.5 Observer Sampling Priorities, Duties and Required Skills

Observers are responsible for a wide array of duties. Observers must be able to work under demanding conditions, both psychological and physical. There are times when you will not be able to complete all duties. Use the list below, ordered from highest to least important, to prioritize when it is not possible to complete all duties. For each duty (left column), there is an associated list of required skills (right column).

Duties	Skills
1. For each gear deployment, record total fishing effort (e.g., position, time) and make an independent estimate of total catch on a random subset of gear deployments (Trawl Effort-Catch;Pelagic Longline-Set-Haul Information;Purse Seine-Daily Activity Log);	<ul style="list-style-type: none"> • Understand navigational and position information • Be able to review the vessels fishing log, assess validity and transfer information correctly • Select appropriate random sample table (RST) and use RST correctly • Apply mathematical formulas to calculate total catch weight
2. Estimate weight and/or numbers of all species caught (catch composition) and establish disposition (e.g. retained, discarded) on random subset of hauls (Catch composition forms)	<ul style="list-style-type: none"> • Understand random sampling concepts, correctly apply different sampling strategies depending on situation and accurately record sampling methods • Accurately identify target species and common bycatch species • Become familiar with vessel operations so that percent retained can be assessed using the observer's random sample (not applicable to shrimp trawl)
3. Collect biological information (e.g.	<ul style="list-style-type: none"> • Apply appropriate sampling strategy

sexed lengths) from target on all (Pelagic Longline Catch Composition) or a subset of hauls (generic Length form);	to collect random subsample of lengths <ul style="list-style-type: none"> • Be able to determine gender of target species
4. Collect biological information (e.g. lengths) from non-target species on a subsample of hauls (Length form);	<ul style="list-style-type: none"> • Same as #3
5. Monitor fish or fish product offloads and transshipments	<ul style="list-style-type: none"> • Be familiar with vessel's product labels
6. Document vessel sightings including vessel name, type, IUU activity, location (Vessel and Aircraft Sighting Form);;	<ul style="list-style-type: none"> • Understand navigational and position information • Coordinate assistance from captain/crew
7. Collect catch and biological data on marine mammals and sea turtles (Marine mammal or sea turtle catch form).	<ul style="list-style-type: none"> • Accurately identify species
8. Record information on sightings of marine mammals and sea turtles in the vicinity of the fishing vessel (Marine mammal and sea turtle sighting form).	<ul style="list-style-type: none"> • Accurately identify species
9. Document types of vessel equipment utilized (e.g. gear characteristics, electronics) and record vessel characteristics (e.g. registration numbers, licenses, etc) (Gear Description, Vessel and Trip forms).	<ul style="list-style-type: none"> • Be familiar with the type and construction of fishing gear used and measure and otherwise take note of any special meshes or attachments to the gear which may affect its performance
10. Accurately record all data on relevant forms or in the observer logbook.	<ul style="list-style-type: none"> • Attention to detail • Understand how the forms and different elements of information are inter-related
11. Document any instances of gear loss in the observer logbook.	<ul style="list-style-type: none"> • Coordinate with captain or deck crew
12. Document suspected violations (including permit conditions) – see Chapter 12 for documentation protocol;	<ul style="list-style-type: none"> • Understand the permit conditions and be familiar with fishing regulations • Be able to bring any issue or discrepancy to the attention of the Master in simple language and if necessary report the issue or discrepancy to the SOP
13. Preparing reports and providing the	<ul style="list-style-type: none"> • Attention to detail

vessel captain with an opportunity to include any information or statements deemed relevant.	
14. Report to SOP according to communications schedule.	<ul style="list-style-type: none"> • Ability to use vessel's communication equipment (radio, cell phone, email)

2.5.1 Code of conduct

Observers have an important image to maintain as professional data collectors. Observers must avoid behaving in a manner that could adversely affect the public confidence in the integrity of the SOP, the data provided or other observers. Observers should adhere to the following code of conduct:

1. Observers must perform their assigned duties as described in the Scientific Observer Sampling Manual.
2. Observers must accurately record their sampling data, write complete reports and report accurately any observations of suspected violations.
3. Observers must not disclose collected data or observations to any person other than the vessel owner or operator of the observed vessel or observer program staff (e.g. fishing positions, catch). Observers shall ensure that data and information collected while on board are kept secure and confidential at all times.
4. Observers shall develop a diligent and professional working routine as soon as possible upon boarding vessel. Observers must maintain an unbiased and/or neutral approach to fisheries management issues while on the job.
5. Observers must maintain their independence at all times and must report any attempt to compromise or harass them.
6. Observers must refrain from engaging in any illegal / inappropriate actions. These includes, but are not limited to:
 - Engaging in the use, possession or distribution of illegal drugs;
 - Drinking alcohol on board the vessel;
 - Soliciting or accepting bribes in money or kind (e.g. gifts, favors, etc.) for neglect of duty or any other act deleterious to their proper duties;
 - Engaging in physical sexual contact with vessel personnel;
 - Falsification of data.
7. Observers shall not have a direct financial interest in the vessel s/he is deployed on. The interests of a spouse or minor child are considered those of the observer.
8. Observers shall ensure that they do not hinder or interfere with the proper functioning of the vessel for fishing or navigation purposes and shall respect the safety and sanitary rules of the ship.
9. Observers shall attempt at all times to have a professional and courteous relationship with the master and crew.
10. Observers will respect all property and equipment and living space on board the vessel, including documents, logbooks and plans of the vessel.
11. Observers are not law enforcement officers but will be firm, fair and tactful in giving official notice to the Master, captain and/or any member of the crew. Observers have no authority to apprehend or direct any fishing vessel or give operational advice.

12. Observers shall refrain from using bad language, exhibiting bad behavior and making public complaints about other persons on board the vessel or on shore.
13. Observers should attempt to walk away from arguments or confrontations.
14. Observers shall not smoke in areas where this is forbidden.
15. Observers will respect the various customs and cultures of the vessels and crew they are involved with.
16. Observers are not crew. While voluntarily helping out with day to day chores or fish sorting is perfectly acceptable (and encouraged), there are a few things to avoid: deploying/retrieving gear, standing watch or serve as the regular cook.

3 Essential Information

3.1 Learning Objectives

- List five components that must be completed in the Observer Logbook
- Describe three types of communications equipment (including advantages and disadvantages of each)
- Demonstrate how to call another vessel on the VHF radio
- Calculate the distance between two points on a chart
- Define random sampling and explain why it is important
- List at least three levels where sampling occurs
- Describe how to use the random sample and number tables

3.2 Introduction

This chapter provides a brief overview of the types of data collected by the SOP and describes the Observer Logbook. Next, it reviews some basic components of at-sea life including nautical terminology, communication options and navigation equipment as well as fundamental statistical concepts. The chapter concludes with tips for the first day or two on board.

3.3 Data collection overview

The SOP is tasked with collecting an assortment of data from commercial fisheries. Each type of data serves a specific purpose relating to fisheries management or stock assessment science. There are five primary data types:

1. **Fishing Effort Information** – This data is used by managers to understand where fish are caught, what gear is used, which species are targeted and how much effort it takes to catch these fish.
2. **Total Catch Estimation** – the amount of fish and other biological material removed is important for both management and stock assessment.
3. **Catch Composition** – Catch composition data is used to estimate relative abundance of each species in a haul. It includes the species specific weights and counts. Catch composition also includes an estimate and reason for discards.
4. **Biological Data** – Biological data is used by stock assessors to gauge the age composition of the population, the length to age ratio, the potential spawning population, and the male to female ratio. It includes determining gender, measuring lengths, taking weights, and collecting age structures from individual fish.
5. **Economic Data** – Economic data is used by economists to determine profitability of the fisheries. Ideally, this information will be collected directly from vessel owners by the management agency.

Each of the data types above are collected at different times and frequencies throughout the trip. For instance,

- For each trip¹, you will complete the Safety and Compliance Checklists, Trip Summary, Vessel Information, and Gear Description forms as well as make entries in the Observer Logbook.
- For each gear deployment, there will be an entry on the Fishing Effort and Total Catch form.
- For each ‘sampled’ gear deployment, a Catch Composition and Length (if assigned) form should be completed.
- Additional forms will be completed as appropriate. These include sightings (animal & vessel), photo log, fish/invertebrate species identification, marine mammal/sea turtle/seabird catch forms and marine debris forms.

Prior to each trip, you should be briefed on any changes to protocol. In addition, if the vessel has previously taken an observer, you should read through the previous observer’s logbook and make note of the vessel diagram and how he or she sampled.

At the end of each trip (or trips), you will go through a debriefing process which includes an in-depth interview regarding how you sampled, data editing and data entry. This is also your opportunity to discuss sampling problems and ideas for making the sampling situation better.

3.4 Observer Logbook

You will be issued an Observer Logbook for each trip. The observer logbook is where all of the details of your deployment will be recorded. Record events as they occur. The following should be recorded on the cover page of the vessel logbook: observer name/code, trip number, vessel name/code, gear type and target species. Within the logbook, there are several forms you will need to complete for each trip: Safety Checklist (Chapter 15), Vessel Information and Trip Summary forms (Chapter 4), and Compliance Checklist (Chapter 12). Finally, there are specific sections for providing a vessel diagram (including measurements of the sample area), a written summary of sampling techniques, a sampling record form, all calculations and formulas used, daily notes, and a photo log.

3.4.1 Calculations

All total catch calculations, must be recorded in your logbook. Average weight calculations (when used to calculate animal counts or sample weights) can be recorded on the catch composition form. Record and label your calculations so that another person could easily understand them without any interpretation. **Calculations may be in pencil, but all other logbook entries should be made in ink!**

3.4.2 Rounding Rules

When you are performing a calculation, carry the numbers out full field (on the calculator) until you have reached your *final product*. Do not round any numbers

Bongo average weight:

$$14.7 \text{ kg} / 50 \text{ fish} = 0.294 \text{ kg per fish}$$

Calculate the number of fish in 75.3 kg:

$$75.3 \text{ kg} / 0.294 \text{ kg per fish} = 256.122448 \approx 256 \text{ fish}$$

$$\text{Incorrect: } 75.3 \text{ kg} / 0.29 \text{ kg per fish} = 259.655172$$

¹ A **fishing trip** is defined as the time between one full or partial offload to the next full or partial offload.

within the calculation! It is important for you to recognize what final product you are calculating when deciding when to round a number. For example, you may need to use an average weight to calculate the total number of fish within your sample (see box). In this calculation, you would not round until you had calculated the total number of that species. It is a common mistake to round once the average weight is calculated. When you round a number to put on a form, round to the number of decimal places required by the column.

To round your final product, look *only at the first digit* to the right of the number you are rounding. If its ≥ 5 round up, if its <5 round down. For example, the final total weight estimate on the Trawl Effort and Total Catch Form is recorded to two decimal places. If your final calculation was 4.9258226, you would round up to 4.93 mt. If your final calculation was 4.9748226, you would round down to 4.97 mt.

3.5 Life at Sea Basics

3.5.1 Living Conditions

Cleanliness, upkeep, safety, comfort of quarters, quality of food, and general attitude of the vessel personnel vary widely from vessel to vessel. Observers must be flexible and function professionally under a wide variety of living conditions. Chapter 14 addresses health and safety aboard commercial fishing vessels in more detail.

General guidelines for being a good shipmate include:

- Show respect to others and it will be returned to you.
- Clean up after yourself and make a conscious effort to maintain a professional appearance.
- Adapt to the situation - observers with an easygoing attitude will likely receive more cooperation than those who criticize and make demands.

3.5.2 Nautical terminology

The maritime industry uses specialized terminology (see also the glossary; Appendix 16). For instance, aft, bow, port, starboard, and stern are all terms referring to directionality on a vessel (Figure 3-1).

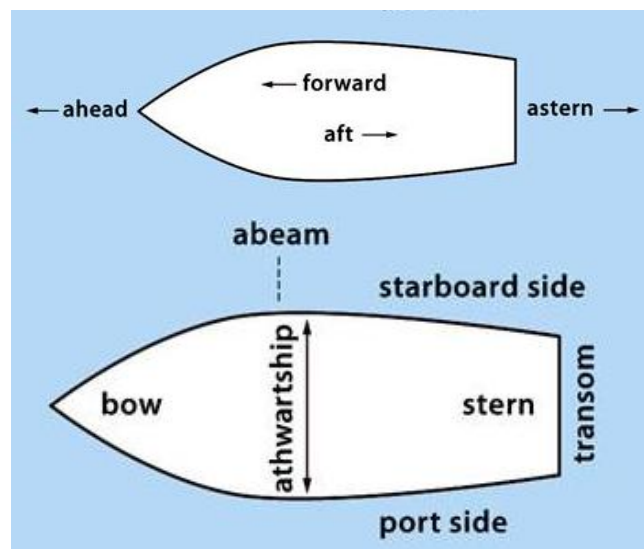

Figure 3-1 Terms for directionality on a vessel. Modified from (United States Coast Guard Auxiliary 2007).

Common nautical terms that may be useful for observers include:

BEAM – vessel width at its widest point.

BEARING - The direction of an object expressed either as a true bearing as shown on the chart, or as a bearing relative to the heading of the boat.

BIGHT - The part of the rope or line, between the end and the standing part, on which a knot is formed.

BILGE - The interior of the hull below the floor boards.

BRIDGE - The location from which a vessel is steered and its speed controlled; also called wheelhouse.

BULKHEAD - A vertical partition separating compartments (e.g., wall).

CABIN - A compartment for passengers or crew.

CAPSIZE - To turn over.

CHART - A map for use by navigators.

COURSE - The direction in which a boat is steered.

CURRENT - The horizontal movement of water.

DECK - A permanent covering over a compartment, hull or any part thereof.

DRAFT - the vertical distance between the waterline and the bottom of the hull (keel), with the thickness of the hull included.

FOREPEAK - A compartment in the bow of a small boat.

GALLEY - The kitchen area of a boat.

HATCH - An opening in a boat's deck fitted with a watertight cover.

HEAD - A marine toilet.

HULL - The main body of a vessel.

LAZARETTE - A storage space in a boat's stern area.

LEE - The side sheltered from the wind.

LINE - Rope and cordage used aboard a vessel.

RUDDER - A vertical plate or board for steering a boat.

SCREW - A boat's propeller.

SCUPPERS - Drain holes on deck, in the toe rail, or in bulwarks.

3.5.3 Communication

3.5.3.1 Types of communication equipment

3.5.3.1.1 Radio

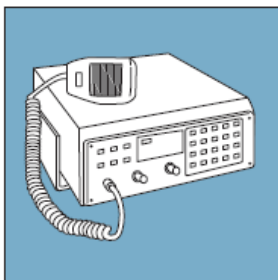

There are two types of radios used by fishing vessels - VHF and SSB. VHF stands for **V**ery **H**igh **F**requency. This band is divided into 71 channels with a frequency range of 156.000 to 163.000 MHz. Channel 16 is the International Distress Safety and Calling Channel. The transmission distance of VHF is a function of antennae height and in general, is slightly more than the distance one can see.

Figure 3-2 SSB Radio. Image from (Transport Canada 2003).

Radio communications over distances beyond twenty miles, will require you to use a high frequency radio frequency referred to as **S**ingle **S**ide **B**and or SSB (Figure 3-2). The frequency range is 2 to 26 MHz. Signal quality is inferior to VHF and susceptible to slight

atmospheric shifts. Lower frequencies are used for medium distances and higher frequencies for greater distances. All ship SSB radios must be capable of operating on 2182 KHz (the International Distress Safety and Calling Frequency) and at least two other frequencies. Depending on national telecommunications rules, you may be required to obtain a radio operators license to use the SSB.

General radio calling guidelines

Radios are different from telephones in that they cannot transmit and receive simultaneously. Keep in mind that people on other ships can also hear your conversations. Speak directly into the microphone; speaking loudly, slowly, and distinctly. Upon completing a transmission you must sign off by identifying your station and using the words "clear" or "out." If you expect to resume contact with the same station soon you may sign off using the phrase "standing by." Remember, in cases other than an emergency, when hailing another station on VHF channel 16 or SSB frequency 2182 you must switch to another working channel after initial contact is established. Finally, keep transmissions short and concise, giving the other station or person a chance to respond, ask questions, or confirm an unclear message. Radio transmissions should be short in duration except for emergency calls.

General calling procedures

1. Make sure radio is on and appropriate channel is selected. Listen momentarily to make sure the channel is not in use.
2. Background static from the radio speaker can be reduced with the squelch control. However, too much squelch can drown out incoming transmissions. Adjust the squelch so that a small amount of static is barely audible or to the point where the static first stops.
3. If there is no traffic on that channel, begin by depressing the button on the microphone and calling the name of the vessel or other station you are trying to contact three times, followed by your vessel name and call sign and the channel you are broadcasting on since most ships and stations listen simultaneously to several channels.

Example: "Delta I, Delta I this is the Bibamba TJAE on channel 16 over."

4. If there is no initial response to your call, wait two minutes before repeating the call. If there is no reply the hail may be repeated at two-minute intervals up to three times, after which you should sign off and wait at least 15 minutes before making another attempt.
5. If contact is established, you must switch to a working channel (VHF) or frequency (SSB) to continue your transmission.
6. When you have temporarily finished talking and are ready to listen, say "over," and release the button on the microphone. When the other party is ready to listen they will say "over."
7. After you have completed your message end with the vessel name, call sign, and the word "out" to signal the end of your transmission. Example: "....Mungo TJBV out."

Distress calling procedures require very specific information to be communicated (see page 15-17 in Health & Safety chapter for more details).

3.5.3.1.2 Mobile phone

When vessels are in mobile or cellular service range, communications can occur via mobile phone. Appendix 2 contains the contact names / numbers of SOP staff.

3.5.3.1.3 Satellite

Some vessels may have satellite service for phone, email and fax. Ask the captain for specific instructions on your vessel.

3.5.3.2 Routine communication with the SOP

Observers will be expected to communicate with the SOP on a regular basis. Each country has its own requirements for the frequency of contact and what you need to report (Appendix 1). The observer will be able to receive/send radio calls using the radio of the vessel. Remember, if you are using the radio, you may need to communicate some of the fishing information using codes provided by the SOP. Alternatively, the observers can send SMS from their cell phones when they are within service range.

3.5.3.3 Emergency communications

In case of a medical emergency, contact the SOP as soon as possible. Appendix 2 lists the contact names / numbers of SOP staff.

3.5.4 Navigation

Navigation is the act of determining a vessel's position, ascertaining speed and directing the course of a ship by using charts and electronic aids.

3.5.4.1 Geographic structure of the earth

The earth is almost spherical in shape with an axis of rotation around an imaginary line through the north and south poles. The equator (0°) is a circle around the earth's surface that is perpendicular to the rotational axis and it splits the earth into two sections – the northern and southern hemispheres (Figure 3-3). Lines of latitude, or parallels, run horizontally circling the globe like a belt. The poles at the furthest north and south locations are at 90° . Lines of longitude, or meridians, run vertically splitting the globe into two sections – east and west. There are 180° of longitude in each direction. When the two systems are combined, you get coordinates that define specific places on the planet.

A position can be expressed in degrees of latitude and longitude. Degrees can be split into smaller units called minutes of arc (these minutes have nothing to do with time). Each degree consists of 60 minutes of arc. Subunits of minutes are in seconds (60 seconds = 1 minute). GPS readings can be in multiple formats (e.g., degrees, minutes, seconds- N $03^\circ 25' 30''$ or degrees, minutes and 10ths of minutes- N $03^\circ 25.5'$ or decimal degrees- N 03.425°). Be aware of the format when recording position data from the vessel's GPS unit.

3.5.4.2 Nautical measurements

A degree of latitude is equal to 60 nautical miles. One nautical mile equals 1,852 meters. Because the meridians of longitude get closer to one another as they approach the poles, distance between degrees of longitude decreases as you approach the poles. Vessel speed is typically measured in knots (1 knot = 1 nautical mile per hour). Commercial fishing vessels rarely travel at more than 10 knots (18 km/hr).

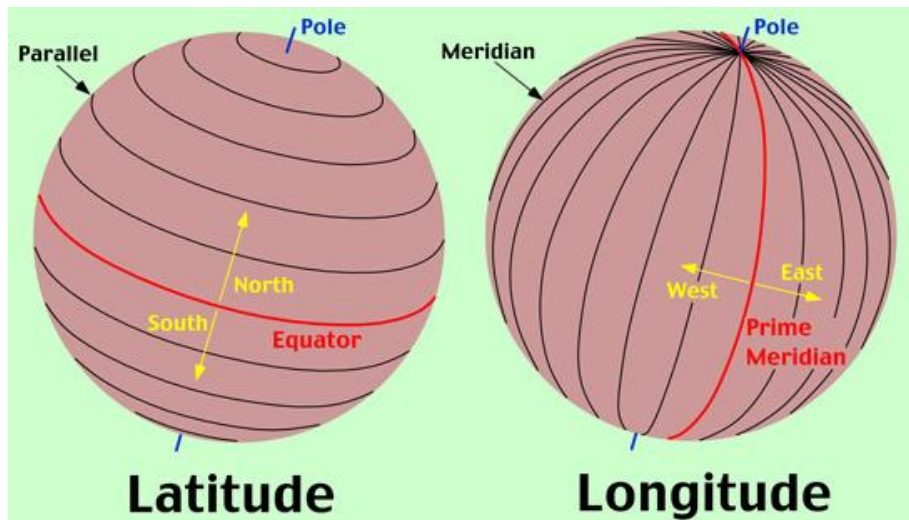

Figure 3-3 Globe with latitude (left) and longitude (right). Image from <http://www.physicalgeography.net/fundamentals/2b.html>.

3.5.4.3 Charts & other navigational aids

A **chart**, the nautical term for a map, is a reproduction of the earth's surface designed for convenient use in navigation. A chart is basically a projection of the earth's sphere onto a flat surface. Most industrial vessels use electronic nautical charts (or a chart plotter) that are linked to GPS, a gyrocompass and/or radar for navigation.

A **compass** is an instrument for determining directions, as by means of a freely rotating magnetized needle that indicates magnetic north. Because a vessel is in constant motion, most vessels have a gyrocompass which in simple terms is a sophisticated compass consisting of a rotating wheel mounted so that its axis can turn freely in all directions. This device may also be referred to as a gyrocompass or just a gyro. The gyro assists the vessel in maintaining the same absolute direction in space in spite of vessel movements.

GPS or a global positioning system is a system of satellites, computers, and receivers that is able to determine the latitude and longitude of a receiver on Earth by calculating the time difference for signals from different satellites to reach the receiver.



Radar uses an electromagnetic wave to detect solid objects (e.g., land or other vessels) day or night and regardless of weather. They may also be used to help find gear (e.g., longline) by detecting radar deflectors attached to the gear. The radar can estimate distance to a given object and determine the speed an object is moving.

A **radio direction finder (RDF)** shows the direction of a radio beacon, which may be situated at an entrance to a port, on top of a light house or on a marker buoy attached to a piece of fishing equipment (e.g., longline or Fish Aggregating Device (FAD)).

3.6 Fundamental statistical concepts

Sampling fish catch may sound simple but collecting a statistically representative sample of commercial catch is challenging. Each vessel and gear type poses unique sampling demands and hazards.

3.6.1 What is a “statistically representative sample”?

In general, it is a selection of individual observations intended to yield some knowledge about a population of concern. For fisheries managers/scientists, the population of concern is all commercial catch and other biological life caught (not just retained) by fishing vessels. When random sampling is used to sample (sometimes called a subsample), **every member of the population must have an equal probability of occurring in the sample.** If every member of the population is equally likely to occur in the sample and sampling is repeated over time, then the collection of samples can be used to draw conclusions about the population.

3.6.2 Why is random sampling important?

Random sampling removes subjectivity and allows managers, fishers and other end users to feel confident that observer data is not biased. When data is collected randomly, scientists can justify using certain statistical methods to estimate population parameters based on the data collected. Sampling allows management agencies to estimate the total weight (or number) of fish removed from the ocean. Sampling may also allow scientists to determine the age of fish taken and a whole suite of other information for assessing the status of fish populations.

Sampling can occur at multiple levels including the fishery (which fisheries will be selected for observer coverage), vessel (which vessels take observers), trip (which trips within vessel), haul and/or net (which hauls are selected for catch composition), and species (which species and/or individual are selected for length, age structures and other biological sampling). Observers will be most concerned with sampling at the haul and species level whereas the management agency must address sampling at the level of fishery, vessel and trip.

Observers will be provided with two different random sample tables (RST) in the Observer Logbook. RSTs prescribe which hauls to sample. Each RST is designed for a different number of hauls per day as follows:

Hauls per day	RST	Target sample rate
1-2	None	100%
3-4	#1	70-75%
5+	#2	65%-70%

General guidelines for haul-level sampling:

- Collect the sample before any sorting occurs (except some shrimp trawl sampling scenarios);
- Do not hand pick the sample. There is a subconscious tendency to select large or otherwise obvious individuals;
- Collect sample from multiple points (on deck or from bin);

- Collect as large a sample as possible. Ideally, a minimum of 20% of the entire catch amount. However, it is better to take a smaller sample and be able to identify individuals to species rather than a larger sample with identification at a higher taxonomic level.

Document all sampling procedures including difficulties and why a set/haul wasn't sampled if it should have been in the Observer Logbook.

3.6.3 Steps in Taking a Random Sample

1. **Define the population.** The population is the total set of items that we wish to draw inferences about. Populations observers take samples from include:

- All individuals in a haul.
- All individuals of a given species in a sample.

2. **Define a sampling frame.** A sampling frame is a conceptual framework, which divides the population into in dependent, countable sampling units. There are two general categories of sampling frames: spatial and temporal.

Spatial – Based on a unit of space or a unit of gear. Examples are:

- **Space** - Bin, Trawl Alley, or Baskets.
- **Gear** –Skate/basket, Tub, Pole, Stick, or Pot.

Temporal – Based on units of time. Examples are:

- Sample 20 minutes of a 60-minute set.
- Collect a sample at a pre-selected point in time.

3. **Define your sample units.** It must be possible to collect *all* individuals within a single unit. Be sure not to use sample units that are so large it may be impossible to collect all individuals. Examples:

- **Spatial** – A trawl alley is divided into six sections. Each of the six sections is a sample unit. Or all catch is shoveled into 10 baskets. Each basket becomes a sample unit.
- **Temporal** – A one-hour sort time is divided into six 10-minute sample units. Each 10-minute segment is a sample unit.

4. **Number all of the sample units in your sampling frame.** If your units are sections of deck or individual baskets, assign a number to each. If your units are time increments, number them consecutively. Gear segments on fixed gear vessels can also be numbered consecutively.

5. **Pick random numbers to choose which units to sample.** Generate random numbers between 1 and your maximum sample unit number (inclusive) to determine which sample unit(s) to select. You will be issued a random number table with your gear and another can be found in Appendix 11 Random Number Tables. Other options for generating random numbers include dice, the second hand of a watch, or numbered pieces of paper.

6. **Select the sample units corresponding to the random numbers.** This is your sample.

- **Spatial** - Collect all of the individuals from each randomly selected deck section, gear unit or basket.
- **Temporal** - Collect all individuals during the time increment.

3.6.4 Random Systematic Sampling

Another way to take a random sample is to set up a random systematic frame. Random systematic sampling can only be used when you know, or have a reasonable estimate of, the **total** number of sample units. Systematic sampling involves taking a sample during every “nth” defined sample unit. For a random systematic frame, randomize the selection of your first sample unit and then take every “nth” unit thereafter. The steps for taking a random systematic sample are the same as #1-4 above. Then,

5. Determine how many of the sample units you want in your sample.
6. Divide the total number of sample units by the number of units you want in your sample. This gives you your value for “n”.
7. Randomly select a number between 1 and n. This will be the first sample unit in your sample.
8. Sample every nth unit thereafter.

Example: There are 25 baskets of unsorted catch.

1. Define population – 25 baskets of catch.
2. Define sampling frame – Spatial Systematic, using baskets.
3. Define sample units – Individual baskets of fish.
4. Number all sample units – Baskets numbered as 1 – 25.
5. Determine how many sample units to sample – Decide to sample 5 baskets or 20%.
6. Calculate value of “n”: $25/5 = 5$.
7. Randomly select a number between 1 and “n” – For our example this = 2.
8. Sample baskets **2**, **7** (2+5), **12** (7+5), **18** (12+5) and **23** (18+5).

More examples for applying random sampling protocols to the specific gear types are in the following chapters. The same general principles apply to selecting individual fish for biological data collection (e.g., lengths, age structures).

3.6.5 Sample Bias

Samples can be biased in a number of ways and how you sample may increase or decrease this bias. For instance,

- Fish stratify within trawl nets while gear is fishing. Therefore, if a sample is collected from only one section, there’s potential for bias.
- Different species may have preferred depth distributions. When sampling fixed gear such as longline, if samples are taken from the same depth strata all the time, then the overall sample may become biased.
- If crew is sorting retained and discard species by hand, these fish may end up being sorted out by size as well as species. Be aware of crew sorting bias if sampling discarded catch after they have sorted. This is not an ideal technique but sometimes the only way you can get a sample.
- Hand selecting fish should be avoided as the natural tendency is to select bigger or brighter specimen.
- Small sample size can influence the variation among the samples and sometimes this can have negative impacts on statistical analyses.

3.7 First day(s) on board

As soon as possible upon boarding a vessel, observers should present their identifications to the Master of the vessel and complete any formalities needed for joining the vessel (Davies and Reynolds 2002). You should coordinate a convenient time to meet with the captain and observer program representative (if possible) to get a vessel tour including assistance needed to complete the Safety Checklist. You should also discuss the quirks of vessel, stowage location for sampling and personal gear and sampling location options. Because the SOP is new for some gear groups, you will likely need to review the objectives of the SOP as well as the observer's role. You should also talk about the types of data collected (i.e. fishing positions, times, estimating total catch and sampling for catch composition, gear characteristics, monitoring of IUU vessels, regulations & violations), the equipment you need access to and discuss the types of information you will need from the captain. You should find out what areas of the vessel are off-limits to you and how best to minimize interference with fishing operations in performing your duties.

Before departing port, complete the Safety Checklist. A good time to work on the Vessel Information form is during the steam to the fishing grounds.

When choosing a sampling location, look for a location that will have:

- 1) minimal interference with vessel operations;
- 2) easy access to catch;
- 3) space to store data sheets and small sampling equipment;
- 4) a place to measure fish;
- 5) a place to hang scales;
- 6) sufficient lighting; and
- 7) is safe (ideally, not under warps or other cables under tension).

Once fishing begins, become familiar with how the crew sorts retained and discarded catch. What are the criteria for retaining each species (e.g., minimum or maximum lengths, certain genders, etc)? Why are various fish/invertebrates discarded and will this be consistent throughout a trip? Make a sampling plan based on your observations of the first 1-2 retrievals.

Familiarize yourself with the species caught. Accurate species identification is a fundamental skill for scientific observers. Take some time the first day or two on board to complete species identification forms and learn the dominant species and species groups that are coming aboard. Start with the retained species and then move on to the discard species.

Finally, as you become familiar with species identification and your composition sampling procedures (1-2 days), practice determining sex for a variety of species before you begin collecting sexed length samples if this duty is assigned to you.

Your first days on board will be overwhelming. **Don't be discouraged – sampling gets easier with practice!**

4 Vessel and Trip Information

4.1 Learning objectives

- Describe two ways data from the Vessel Information form can be utilized.
- List the three primary sections that will be completed on every Vessel Information form.
- Describe two ways information from the Trip Summary form can be utilized.
- List the two primary components of the Trip Summary form.

4.2 Introduction

Information gathered on the Vessel Information form can be utilized to monitor changes in fishing capacity, fishing efficiency as well as processing capability. For instance, larger engines may increase towing power which can increase the size of a net towed by a vessel. If capacity is unknown, a problem with a fish stock may not be easily detected if catch remains constant while fishing capacity increases. Processing capability can have impacts on food quality. The primary sections of the Vessel Information form include: general vessel characteristics (e.g., length, ownership, flag, and engines), electronic equipment such as communications, refrigeration types and capacity and gear-specific sections for purse seine and trawl vessels.

Information gathered on the Trip Summary form can be utilized to observe movement of key crew among the fleet and to simplify the debriefing process by providing a trip overview. The primary components of the Trip Summary form are: general trip characteristics (where & when you boarded, crew, gear type and target species), summary of forms completed and post-trip data tracking fields.

4.3 List of Priorities

1. Complete one Vessel Information form at the beginning of each trip.
2. Complete one Trip Summary form by the end of each trip.

4.4 Forms/Instructions

Vessel Information and Trip Summary forms are part of the Observer Logbook (example in Figure 4-1). The asterisk (*) indicates priority fields.

4.4.1 Vessel Information

Complete one Vessel Information form per trip². Images from (Brogan et al. 2006).

Field	Definition
*Vessel name	Record the vessel name.
*Country Registration No.	Identifying numbers (ie country registration number or Lloyd's number). Use the registration number on the Certificate of Registry.
*Flag	Enter the 3-letter ISO3 country code for nation where vessel is

²By 2011, the frequency may change to once per year since the baseline information should not change very frequently.

flagged (Appendix 5).

Home port	Record the vessel's home port city and country (use ISO3 country code). This may be listed on the stern or Certificate of Registry.
Previous vessel names	List previous vessel names (if known).
Previous flag	Record 3-letter ISO3 country code for nation(s) where vessel was previously flagged (if known).
Length overall	Record total length of the vessel in tenths of meters (to one place past decimal). Obtain from safety certificate, Certificate of Registry or fishing permit.
Draft	Record draft of vessel in meters (tenths).
Beam	Record beam of vessel in meters (tenths). Defined as vessel width at its widest point.
*IMO No.	Record the IMO (or Lloyd's Register-Fairplay) number or "NA" if not available. The International Maritime Organization (IMO) number is seven digits and remains unchanged upon transfer of the ship's registration to another owner/country. Vessels used exclusively for fishing are exempt for mandatory assignment of IMO numbers (http://www.imo.org/TCD/mainframe.asp?topic_id=388).
MMSI No.	Record MMSI or enter "NA" if vessel does not have one. Currently, only vessels > 100 GRT are required to have a Maritime Mobile Service Identity (MMSI) number. It is a series of nine digits which are sent in digital form over a radio frequency channel in order to uniquely identify ship stations, ship earth stations, coast stations, coast earth stations, and group calls (http://en.wikipedia.org/wiki/Maritime_Mobile_Service_Identity).
Int'l Radio Call Sign	International Radio Call Sign (IRCS) – issued by flag nation using standardized International Telecommunication Union prefixes (www.itu.int) Appendix 5 provides list of country names and call sign prefixes. Note that the format varies by country.
Global Registry ID	Record Global Registry Identification or "NA" if vessel does not have one. Note: This registry is currently under development (FAO 2008).
Hull material	Circle the appropriate construction material(s) for hull: wood, iron/steel, fiberglass. If material is different than these three, please circle other and write in the material type.
*Permit /	Record the country-specific fishing permit number. All vessels

license no.	observed by the SOP must have a fishing permit or license. If the vessel is targeting tuna, record the ICCAT Register number in the comments section.
*Permit expiration	Record the date of expiration of the permit/license.
*Tonnage	Enter tonnage of vessel and circle tonnage type: GT – Gross tonnage, NT – Net tonnage, GRT – Gross Registered Tonnage, NRT – Net Registered Tonnage. Currently, GT and NT are the international standard units; however, record the unit recorded on the Certificate of Registry.
Owner name/address	Record the name and address of the vessel owner
*Permit holder name/address	If permit holder is different than the owner, record the name and address of the permit holder. This may also be the ships agent or company representative.
Year built	Enter the year the vessel was built. Typically on the Certificate of Registry.
No. propellers & blades	Record the number of propellers and the number of blades per propeller.
Propeller pitch & diameter	Record the pitch (meters) and diameter (meters) of the propeller(s). Pitch is the displacement a propeller makes in a complete spin of 360° degrees.
Ducted propeller?	Circle Yes if the vessel has a ducted propeller (also called a kort nozzle or rice nozzle) and No if it has regular propellers.
Bow thruster present?	Does the vessel have a bow thruster? Circle Yes or No
Engine (main & auxiliary)	Record the manufacturer and model for each engine as well as kilowatts (Kw) and RPMs. If unit of power is only known in horsepower, be sure to indicate a different unit.
Generator	Record the manufacturer and model as well as power (Kw).
Transmission	Record the manufacturer and model as well as gear ratio.
Winches	Record the manufacturer and model of the deck winches. Also note the type (electric, hydraulic, or other), how many, maximum hoisting weight.

Other	Record manufacturer and model of any other primary equipment not already specified.
Water capacity	Record the capacity for fresh water storage on board (cubic meters).
Fuel capacity	Record the fuel capacity and circle appropriate unit (cubic meters or tonnes).
Fuel consumption	Record the average daily fuel consumption while fishing (tonnes / day)

Electronics: For each device, circle **Yes** or **No** for whether the device was present on board. If present, record a usage code, manufacturer and model and provide additional information requested in the additional information column. Usage codes are defined as:

- | | | | |
|---|---|---|--------------------------|
| 1 | Used continuously during fishing | 5 | Rarely used |
| 2 | Used often during fishing | 6 | Used only during transit |
| 3 | Used sometimes during fishing | 7 | No longer used |
| 4 | Broken during this trip but used normally | 8 | Unknown |

Field	Definition
GPS	Global Positioning Satellite device to determine vessel position in latitude and longitude. Record the accuracy of GPS unit in meters. If range is unknown, record “unknown” in the additional information column.
VMS	Vessel Monitoring System - A VMS in its basic form is essentially a global positioning system (GPS) linked to a satellite communications transponder, with a small processor to poll the vessel automatically and transmit information on the vessel position, course and speed (Flewwelling et al. 2002). Indicate in comment whether the VMS system had an internal or external GPS.
Radar	Device uses electromagnetic waves to locate solid objects. If vessel has more than one type, record secondary radar information in ‘other’ rows. If you are on a purse seine vessel and they have specialized bird radar, record information in purse seine section on back side of form.
Sonar	Device uses sound transmission to estimate bottom depth (also called a depth sounder or echo sounder) or fish in water column (also fish finder). Space is provided for 2 systems. If more than 2 devices, record in ‘other’ rows.





ADCP (current profiler)

Acoustic Doppler Current Profiler – Specialized type of sonar used to detect direction and strength of currents at multiple depths. Record the frequency used in Comments column.



Radio beacon direction finder

Device used to find radio buoys.



Radio buoys / beacons

Include how many the vessel has on board and the frequencies they transmit on.

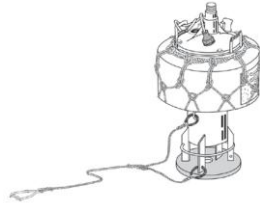

GPS buoys

Include how many the vessel has on board.



SST gauge

Temperature sensor to monitor sea surface temperature which can be important for finding some fish species.



XBT (bathythermograph)

An expendable bathythermograph is a specialized device used to collect a temperature profile at varying depths. The information is used to find thermoclines, ocean fronts or current eddies that will indicate the presence of fish especially tuna. Vessels may have automated or manually operated XBTs. If an XBT is used by the vessel, a probe may be deployed regularly.



Other

Complete for other devices as necessary.

Communications: Circle **Yes** or **No** and provide appropriate numbers/codes for the communication equipment on board.

Satellite

Include the phone number and the provider of satellite service.



Fax

Record the fax number if applicable

Email:

Provide the email address if available

VHF

Record how many **V**ery **H**igh **F**requency radios are on board.

SSB

Record how many **S**ingle **S**ide **B**and radios are on board.

GMDSS

The **G**lobal **M**aritime **D**istress **S**afety **S**ystem is an internationally agreed-upon set of safety procedures, types of equipment, and communication protocols used to increase safety and make it easier to rescue distressed ships, boats and aircraft.

(http://en.wikipedia.org/wiki/Global_Maritime_Distress_Safety_System)

AIS

Automatic **I**dentification **S**ystem is a short range coastal tracking system. If there is an AIS on board, note the class type (A or B).

Weather fax

Does the vessel have a weather fax?

Other

Provide information on any additional communications equipment on board.

Refrigeration: Circle **Yes** or **No** for the presence various refrigeration types on board and for all “Yes” responses, record the capacity.

Blast freeze?

Blast (or plate) freezers are able to quickly freeze product to extremely cold temperatures. Unit of capacity is tons /day. If applicable, record which gas is used for the freezing process (e.g., freon, ammonia).

Freezer hold?

Unit of capacity is volume (e.g. cubic meters)

Ice?

Unit of capacity is volume (e.g. cubic meters)

RSW

Refrigerated **s**ea (salt) **w**ater is typically used to transport small pelagic fish. Unit of capacity is a volume (e.g. cubic meters)

- Brine A super-saturated solution of salt water, commonly used for tuna. Unit of capacity is volume (e.g. cubic meters)
- Other If vessel uses some other form of refrigeration, please describe and include the capacity.

Waste Management: Check all methods of waste (rubbish) management used by the vessel and list types of materials for each. For example, plastics may be disposed on shore and galley food waste may be thrown overboard.

Purse Seine: Complete this section only if this trip was on board a purse seine vessel. For each device, circle yes or no for whether the device was present on board, record a usage code (same definitions as Electronics section), and provide additional comments as necessary.

- Ring stripper Device that automatically feeds the purse rings onto a drum or other apparatus during gear retrieval. Also referred to as hairpin.
- Speedboats Record the number of functional speed boats on board and their engine power (e.g., 3: 45, 45, 65 hp).
- Raft Did the vessel have a raft or personal watercraft for assisting with the release of marine mammals?
- Bird radar This may be in addition to radar above.
- Net mensuration Record the make/model of any net measuring equipment/sensors the vessel used to detect the shape of the net when deployed.
- Diver / dive equipment Ask the captain if there is a person on board who will act as a diver for the release of marine mammals. Was a diver ever used to rescue dolphins or other marine mammals from net?
- High-intensity floodlight Was the vessel equipped with a high-intensity floodlight and was it in operable condition. This is important if setting on dolphins and retrieval extends into night.
- Spotter aircraft Circle type: aircraft or helicopter or none. Also provide the manufacturer, model, registration number, and range (in kilometers) it can fly without returning to the vessel.

Trawl: Complete this section only if this trip was on board a shrimp or finfish trawl vessel. For each device, circle yes or no for whether the device was present on board, record a usage code, manufacturer and model, and provide additional comments as necessary.

- Bottom contact sensor Used to monitor footrope or door contact with bottom.

Catch sensors	Used to monitor fullness of net
Net sensors	Used to monitor net opening (e.g. horizontal and vertical spread) as well as catch entering the net. Circle whether or not this system is hard Wired (via a third cable) or wireless .
Hydrophone	Hull mounted receiver or towed hydrophone used to communicate with various net monitoring devices.
Other	Record additional devices as necessary.

Comments: Use this space to provide further information regarding fields on this form.

Vessel Information

General Vessel Characteristics									
Vessel name HappySailer		Country Registration No. XYZ 3856			Flag SLÆ		Home port (city, country) Freetown, SLÆ		
Previous vessel names		Previous flag			Length overall (LOA; m) 23.5		Draft (m) 5 Beam (m) 8		
IMO No.		Int'l radio call sign (IRCS) 9LC 27			Hull material (circle): Wood / (Steel) Fiberglass / Other _____				
MMSI No. 123456789		Global Registry ID:			Tonnage: 187 (GT) NT / GRT / NRT				
Permit/license No. SLÆ 27		Permit expiration (dd-mm-yy): 31-12-09		Year built 1976					
Owner Name/address Sailer Tom 7 Prawn Road Lungi, SLÆ		Permit holder name/address same as owner			No. propellers: 1 No. blades: 3		Propeller pitch: Diameter (m): 1.1		
				Ducted propeller? Y / (N)		Bow thruster present? (Y) / N			
		Manufacturer		Model					
Engine (main)		Caterpillar		C32		Kw: 1156		RPM: 2300	
Engine (auxiliary)		Caterpillar		C18 ACERT Aux		Kw: 372		RPM: 1800	
Generator		Caterpillar		C18 ACERT Genset		Power (Kw) 50 Hz - 275 kw			
Transmission (gear box)		Renk				Ratio 1.5-4			
Winches (on deck)		TWG		H8		Type: Electric / (Hydraulic) / Other _____			
How many? 2				Max hoisting weight 3800 kg					
Other:									
Other:									
Water capacity (m3): 2000		Fuel capacity: 75 m3 (tonnes)		Fuel consumptions (tonnes/day): 1.6					
Electronics									
					Present?	Usage	Manufacturer	Model	Additional Information
Plotter & GPS		GPS	(Y) / N	1	SAMYUNG ENC	SGP-330	Accuracy (m) 15		
		VMS	(Y) / N	1	BlueTraker		GPS: (Internal) / external		
		Radar	(Y) / N	1	Samyung	SMR-3600	KHz:		
		Sonar	(Y) / N	1	Simrad	ES60 Single	KHz: 120		
		Sonar	Y / N				KHz:		
		ADCP (current profiler)	Y / (N)				KHz:		
		Radio beacon direction finder	Y / (N)						
		Radio buoys / beacons	Y / (N)				How many?	Frequency:	
		GPS buoys	Y / (N)				How many?		
		SST gauge	Y / (N)						
		XBT (Bathythermograph)	Y / (N)						
Other:			Y / N						
Other:			Y / N						
Other:			Y / N						
Other:			Y / N						
Usage Codes									
1 Used continuously during fishing		5 Rarely used							
2 Used often during fishing		6 Used only during transit							
3 Used sometimes during fishing		7 No longer used							
4 Broken during this trip but used normally		8 Unknown							

Communications	Satellite	<input checked="" type="radio"/> Y / <input type="radio"/> N	Phone No.	111 111 111	Provider:	Iridium
	Fax	<input checked="" type="radio"/> Y / <input type="radio"/> N	Fax No		Email	<input checked="" type="radio"/> Y / <input type="radio"/> N
	VHF	<input checked="" type="radio"/> Y / <input type="radio"/> N	#:	4	GMDSS	<input checked="" type="radio"/> Y / <input type="radio"/> N
	SSB	<input checked="" type="radio"/> Y / <input type="radio"/> N	#:	2	AIS	<input checked="" type="radio"/> Y / <input type="radio"/> N
Other Information	Weather fax	<input checked="" type="radio"/> Y / <input type="radio"/> N	Other:			<input type="radio"/> Y / <input type="radio"/> N
	Other:	<input checked="" type="radio"/> Y / <input type="radio"/> N	Other:			<input type="radio"/> Y / <input type="radio"/> N

Refrigeration						
Blast freeze?	<input checked="" type="radio"/> Y / <input type="radio"/> N	Capacity (t/day):	15	Gas:	RSW?	<input checked="" type="radio"/> Y / <input type="radio"/> N
Freezer hold?	<input checked="" type="radio"/> Y / <input type="radio"/> N	Capacity (m3):	1587	Gas:	Brine?	<input checked="" type="radio"/> Y / <input type="radio"/> N
Ice?	<input checked="" type="radio"/> Y / <input type="radio"/> N	Capacity:		Other:		<input checked="" type="radio"/> Y / <input type="radio"/> N

Waste Mangement (check all that apply & note types of materials for each)			
Incinerator:		<input checked="" type="checkbox"/> X	Dispose on shore: everything but paper
Burned on board:		<input checked="" type="checkbox"/> X	Throw overboard: Paper

Purse Seine				
	Present?	Usage	Comments	
Ring stripper?	<input checked="" type="radio"/> Y / <input type="radio"/> N			
Speedboats	<input checked="" type="radio"/> Y / <input type="radio"/> N		How many?	Engine power (hp):
Raft	<input checked="" type="radio"/> Y / <input type="radio"/> N			
Bird radar	<input checked="" type="radio"/> Y / <input type="radio"/> N			
Net mensuration	<input checked="" type="radio"/> Y / <input type="radio"/> N		Make / Model	
Diver / dive equipment	<input checked="" type="radio"/> Y / <input type="radio"/> N		Used to rescue dolphins?	
High-intensity floodlight	<input checked="" type="radio"/> Y / <input type="radio"/> N		Operable? <input type="radio"/> Y / <input type="radio"/> N	
		Manufacturer	Model	Registration
Spotter aircraft: plane / helicopter / none				Range (km)

Trawl					
Sensors	Present?	Usage	Manufacturer	Model	Comments
Bottom contact	<input checked="" type="radio"/> Y / <input type="radio"/> N				
Catch	<input checked="" type="radio"/> Y / <input type="radio"/> N		Simrad	PI Catch	
Net sensors	<input checked="" type="radio"/> Y / <input type="radio"/> N		Simrad	FS70	<input checked="" type="radio"/> Wired <input type="radio"/> wireless
Hydrophone	<input checked="" type="radio"/> Y / <input type="radio"/> N				Hull mounted / towed
Other: Warp winch-2	<input checked="" type="radio"/> Y / <input type="radio"/> N	1	TWG	M30	11,340 kg pull capacity
Other:	<input type="radio"/> Y / <input type="radio"/> N				
Other:	<input type="radio"/> Y / <input type="radio"/> N				

Comments:

Version 1.0 6/2010

Figure 4-1 Example Vessel Information form.

4.4.2 Trip Summary

Complete one trip summary form for each trip on board a vessel (Figure 4-2).

Field	Definition
Embarkation, Departure, Return and Debarkation: enter dates, times and locations. Also make a note if the vessel made additional stops during the fishing trip.	
Date	Record date in day/month/year (dd/mm/yy) format
Time	Record time in 24-hr notation (e.g. 1:05 pm = 1305)
Time zone	Record the time zone in which the vessel operated and you recorded data. This must be consistent throughout the trip. Record the number (+/-) of hours in Coordinated Universal Time (UTC). See map in Appendix 9.
Port	Enter the city & country code (Appendix 5). If transfer to or from a vessel occurs at sea, also record vessel name, location for vessel transfers.
Captain, First Mate and Fish Master	
Name/address	Record full name and address of each primary officer. This may be the company address.
Nationality	Record nationality for each person
Years in fishery	Enter the number of years each has worked in the fishery
Crew size	Record the total number of crew on board (excluding the observer)
Crew List?	Circle Yes or No . Ideally, the crew list would be a full manifest of all crew member names, position on board and nationality
Gear type	Circle appropriate gear type as defined below and if otter trawl, fill in appropriate number. If you are on a vessel that is using a different gear type, record most appropriate gear type based on the complete list in Appendix 6.

TBB	Beam trawl
OTB-1	Otter trawl – bottom – side deployment
OTB-2	Otter trawl – bottom – stern deployment
OTM-1	Otter trawl – midwater – side deployment
OTM-2	Otter trawl – midwater – stern deployment
TBS	Shrimp trawl
PS	Purse seine – 1 vessel (Note: there's a different code if using 2 vessels)

LLD	Drifting or pelagic longline
LLS	Set or demersal longline
GND	Drifting gillnet

Primary and secondary target species	Ask the captain what the primary and secondary target species are and record 3-letter species codes (0). Only report primary target if there is only one.
Packaging	Circle packaging types utilized: Boxed or bagged / Binned on ice / Loose.
Fish sales	Record the location and buyer name if you are on board when fish are offloaded.
Products	For each product type, list the record 3-letter species codes (0) that were retained on board.

Debriefing Section

Forms Completed - Place an 'X' next to each form type that you completed during this trip.

Total sets/hauls	Record the total number of sets/hauls made on this trip
# sets/hauls sampled	Record the number of sets/hauls sampled for catch composition during this trip
Mortality and Sightings	Circle Yes or No for marine mammal, sea turtle or seabird mortality and sightings. Record species codes (0) and number encountered for all Yes responses
Accommodations	Circle Yes or No as appropriate.
# crew assigned to room	Record the number of people assigned to your room (including yourself)
Storage	Did you have adequate storage for personal and sampling gear?
Food	Was the food served on board at least 2x/day?
Water	Was there fresh, clean drinking water on board?
Toilet	Was a toilet available on board? If no, describe what was used (ie, bucket, etc).
Sampling	Do you have any advice for future observers regarding sampling

advice? on this vessel?

Debriefing & Data checking

Debriefer name Enter debriefer name

Debriefing date / location Record the date and location (city) of debriefing

Date data submitted Record date data was submitted by the observer to the SOP

Date data finalized Record date that data was finalized by the SOP

Date data entry Record date that data was first entered into database

Date data entry verified Record date that data was verified in database

Trip Summary				
Embarkation	Date (dd/mm/yy) 18-09-09	Time (24-hr clock) 1045	Time zone (+/- hrs) 0	Port (city, country) Conakry, GIN
Departure	Date (dd/mm/yy) 19-09-09	Time (24-hr clock) 0500	Port (city, country) Conakry, GIN	
Return	Date (dd/mm/yy) 27-11-09	Time (24-hr clock) 2300	Port (city, country) Freetown, SLE	
Debarkation	Date (dd/mm/yy) 28-11-09	Time (24-hr clock) 1530	Port (city, country) Freetown, SLE	
Additional stops?				
Captain name / address Finn Malulu, 100 Tuna Ave, Conakry, GIN			Nationality SLE	Years in fishery 12
Mate name / address Mac Diel, Accra, GHA			Nationality GHA	Years in fishery 7
Fish master name / address			Nationality	Years in fishery
Crew size (excl. observer)	17	Crew list attached?	Y / <input checked="" type="radio"/> N	
Gear type (circle one)	TBB / OTB-__ / OTM-__ / TBS / PS <input checked="" type="radio"/> LLD / LLS / GND / Other: _____			
Primary target BET	Packaging (circle one)	Boxed or bagged / Binned on ice / <input checked="" type="radio"/> Loose / Other _____		
Secondary target YFT				
Fish sales				
Location(s):		Freetown, SLE		
Buyer name(s):		Bigshot Bob		
Products (list species groups for each)				
<input checked="" type="checkbox"/>	Whole:	BSH		
	Tail off:			
	Head off:			
<input checked="" type="checkbox"/>	Head & tail off:	SWO		
	Head off & gutted:			
	Fillet:			
<input checked="" type="checkbox"/>	Other:	Gilled: & gutted: BET, YFT, SKI, ALB		
	Other:			

Debriefing									
Forms Completed (check all applicable)									
Observer Logbook	<input checked="" type="checkbox"/>	Compliance checklist	<input checked="" type="checkbox"/>	Vessel and aircraft sighting	<input checked="" type="checkbox"/>				
Vessel Information	<input checked="" type="checkbox"/>	Safety checklist	<input checked="" type="checkbox"/>	Floatsam (PS only)					
Trip Summary	<input checked="" type="checkbox"/>	Species ID (new spp encountered)	<input checked="" type="checkbox"/>	Daily log (applies to PS only)					
Gear Description	<input checked="" type="checkbox"/>	Lengths		<i>Fish Health & Sanitation Audit</i>	<input checked="" type="checkbox"/>				
Total catch & effort (set/haul)	<input checked="" type="checkbox"/>	Age structures							
Catch composition	<input checked="" type="checkbox"/>	Photo log	<input checked="" type="checkbox"/>						
Total sets/hauls	42	# sets/hauls sampled	40						
Mortality & sightings (circle Y or N for each)									
		Mortality	Species (code, #)	Sightings	Species (code, #)				
Marine mammal	<input checked="" type="checkbox"/>	<input checked="" type="checkbox"/>		<input checked="" type="checkbox"/> / N	<i>DSA-2; PYW-1</i>				
Sea turtle	<input checked="" type="checkbox"/>	N	<i>TTL, 1</i>	Y / <input checked="" type="checkbox"/>					
Seabirds	<input checked="" type="checkbox"/>	N	<i>PRX, 1</i>	Y / <input checked="" type="checkbox"/>					
		Y / N		Y / N					
Accommodations									
# crew assigned to room	3	Fresh water	<input checked="" type="checkbox"/> / N						
Adequate storage	<input checked="" type="checkbox"/> / N	Toilet	Y / <input checked="" type="checkbox"/>	<i>used bucket on deck</i>					
Food	<input checked="" type="checkbox"/> / N								
Sampling advice? <i>Bring extra snacks unless you like fish for every meal</i>									
Debriefing and data checking/tracking									
Debriefing name									
Debriefing date / location									
Date data submitted		Date data entry							
Date data finalized		Date data entry verified							
Debriefing Notes									
Version 1 6/2010									

Figure 4-2 Example Trip Summary form

5 Catch Composition Form

5.1 Learning objectives

- Describe the guidelines for selecting hauls for catch composition.
- List and define five of the eight primary elements of the catch composition form.

5.2 Introduction

Scientific observers will collect a random sample for catch composition from a subset of hauls. There are a few exceptions where each haul/set will be sampled (e.g., pelagic longline and tuna purse seine). Catch composition data is used to estimate relative abundance of each species in a haul. All catch within the sample should be identified to the species or lowest possible taxonomic level. Catch composition includes the species-specific weights and counts as well as an estimated quantity retained and reason for discards.

The term “haul” will be used throughout the gear-specific chapters; however, the terms haul, set, station or shot when used as nouns, refer to a fishing event from beginning to end. Since slightly different sampling procedures apply to the various gear types, more specific information on sampling procedures and expectations are described more fully in the gear-specific chapters.

The general guideline for selecting hauls for catch composition sampling is:

- If there are 1-2 hauls per day, sample all hauls;
- If there are 3-4 hauls per day, use Random Sample Table (RST) #1 to select hauls;
- If there are 5 or more hauls per day, use RST#2 to select hauls.

Both RSTs and more detailed instructions on their use are in the Observer Logbook.

5.3 List of Priorities

1. Randomly select hauls to sample for catch composition and document procedure in Observer Logbook.
2. Collect sample to determine catch composition from selected hauls.
3. Complete catch composition form for each sampled haul.

5.4 Forms/Instructions

5.4.1 Catch Composition Form

Complete one catch composition form for each sampled haul (see Figure 5-1).

Field	Definition
Observer Code:	Write the observer program identification code assigned by the program.
Vessel Code:	Record the vessel code (Appendix 3). If your vessel is not on this list, contact the SOP immediately.

Trip ID Enter the trip identification number assigned by the SOP.

Date Record the date haul was retrieved (dd/mm/yy).

Haul Record the haul number.

Mixed? Was this haul mixed with another prior to sampling? Circle **Yes** or **No**. This should not happen often.

Species Name Record the common or scientific name for the species. Note that if there are multiple sample types, there may be more than one entry (row) for some species. For example, shrimp species A may be part of the retained species sample (sample type 3A) and part of the discard sample (sample type 3C).

Code Record the 3-letter code for the species or species group (0).

ST Record the appropriate code for **Sample Type**. Codes are defined as follows:

1	Whole haul	The entire haul was monitored for this species and you are 100% confident that all individuals were seen.
2	Unsorted random sample	Used for trawl samples collected before crew does any sorting
3A-C	Sorted sample	Used for trawl samples collected after crew sorts retained from discards.
3A	Retained (sorted by species)	All retained fish that have been sorted to species should be weighed. Collect a random subsample of retained species that are mixed together (typically smaller sizes of several similar looking fish). Sort & weigh by species. Estimate total weight of the mixed species and record on page 2.
3B	Retained (mixed species)	
3C	Discard sample	Collect a random subsample of discards. Sort & weigh by species or species groups. Estimate total weight of the discards and record on page 2.
4	Longline, bottom	Use for Marine Mammals and Sea Turtles if you are not 100% certain
5	Gillnet	
7	Other	

you saw all marine mammals or sea turtles. May also be used if an individual was sorted out of the catch before you could collect your sample (e.g., large shark).

Note: If code 3 is used, there must be an entry for 3A and 3C at a minimum. Pelagic longline and purse seine have their own catch composition forms.

Number	Record the count of animals for each species or species group in the sample. This may be a direct count or can be calculated by dividing the sample weight by an average weight. Record all calculations in the space provided at the bottom of the form (back side).
Weight	Record the weight of each species or species group in the sample.
Sample weight	Record a unique sample weight for each sample type. The sample weight for a whole haul is the total catch weight from the total effort and catch form. For example, if one sea turtle was caught, this would be considered a whole haul sample. The sample weight for an unsorted random sample (ST=2) is the sum of all species weights from that sample.
% Ret.	Record the percentage of each species (species group) retained by weight for sale or onboard consumption.
Reason Discard	If % retained is <100, enter the most appropriate code describing the reason discard occurred. <ol style="list-style-type: none"> 1 Regulation (e.g., retention of species not allowed or size restrictions) 2 Market (e.g., there is currently no market to sell this species) 3 Damaged (e.g. fish was eaten by another species on line or in net) 4 Marketable but sorting error (common in shrimp trawl fishery) 5 Other – make notes in the comment section regarding other reasons for discard

There may be more than one sample type and associated sample weight for a given haul. For instance, a haul could contain a marine mammal (recorded as sample type “1” for whole haul) and a random sample of all other catch (recorded as sample type “2”).

Record “APL”, “X2” or “X1” for miscellaneous vegetation and plant material, plastic material and all other rubbish (excluding plastics), respectively.

Observer code		Vessel code		Trip ID	Date (dd/mm/yy)	Haul	Mixed?
SLE 0001		12345		75	24/03/10	223	Y (N)
Sample Type (ST)						Reason Discard	
1 Whole haul	3A	Shrimp trawl I - retained by species		4 LL-bottom		1 Regulation	4 Error
2 Unsorted random	3B	Shrimp trawl I - retained mixed species		5 Gillnet		2 Market	5 Other
	3C	Shrimp trawl I - discard sample				3 Damage	
Species Name	Code	ST	Number	Weight	Sample Weight	% Ret.	Reason Discard
<i>Penaeus notialis</i>	SOP	3A	700	35	113.78	100	
<i>Caranx hippos</i>	CVJ	↓	17	4.25	↓	↓	
<i>Drepane africana</i>	SIC	↓	2	1.04	↓	↓	
<i>Galeoides decadactylus</i>	GAL	↓	26	8.84	↓	↓	
<i>Lutjanus goreensis</i>	LJO	↓	3	3.15	↓	↓	
<i>Pentanamus quinquarius</i>	PET	↓	98	10.78	↓	↓	
<i>Raja miraletus</i>	JAI	↓	2	5.4	↓	↓	
Crab, Unid	CRA	↓	1	1.5	↓	↓	
<i>Portunus validus</i>	PVQ	↓	2	1.6	↓	↓	
<i>Sepia officinalis</i>	CIC	↓	4	2.2	↓	↓	
<i>Pseudolithus sp</i>	CKW	↓	45	16.2	↓	↓	
<i>Pomadourus jubelini</i>	BUR	↓	9	2.07	↓	↓	
<i>Trichiurus lepturus</i>	LHT	3A	87	21.75	113.78	↓	
<i>Drepane africana</i>	SIC	3B	3	0.69	20.99	↓	
<i>Galeoides decadactylus</i>	GAL	↓	33	3.3	↓	↓	
<i>Lutjanus goreensis</i>	LJO	↓	7	4.2	↓	↓	
<i>Pentanamus quinquarius</i>	PET	↓	53	2.65	↓	↓	
<i>lati</i>	ILI	3B	29	10.15	20.99	100	
Shrimps, unid	DCP	3C	300	15	47.15	0	3/4
Bivalves	CLX	↓	19	0.95	↓	↓	2
<i>Brachyleuterus auritus</i>	GRB	↓	3	0.3	↓	↓	2
<i>Galeoides decadactylus</i>	GAL	↓	20	3.6	↓	↓	2
<i>lati</i>	ILI	↓	75	7.5	↓	↓	2
<i>Raja miraletus</i>	JAI	↓	5	1.75	↓	↓	1
<i>Sardinella maderensis</i>	SAE	↓	17	1.7	↓	↓	2
Plant material	X1	↓	1	10.5	↓	↓	
Crab, Unid	CRA	↓	17	0.85	↓	↓	1
Plastic	X2	3C	1	5	47.15	0	
Notes / Calculations						Total weight	
Sampled 1 of 4 baskets of mixed species (sample type 3B) and 2 of 10 baskets of discard (sample type 3C);						3A	113.78
$SOP\ ave. = 2.5/50 = 0.05\ kg$						3B	80.75
$SOP\ no. = 35.0 / 0.05 = 700$						3C	224.5
$LHT\ ave. = 6.25 / 25 = 0.25\ kg$							
$LHT\ no. = 21.75 / 0.25 = 87$							
$lati\ ave. = 4.0/40 = 0.1\ kg$							
$lati\ no. = 7.5 / 0.1 = 75$							
$PET\ ave. = 3.85 / 35 = 0.11\ kg$							
$PET\ no. = 7.5 / 0.11 = 98$							

Version 1.0 6/2010

Figure 5-1 Catch Composition example.

6 Trawl – Finfish

6.1 Learning objectives

- Explain the differences between beam and otter trawls.
- Describe two methods to estimate total catch.
- List the 3 forms that are specific to finfish trawlers
- List 4 things that may impact how you sample.

6.2 Introduction

Trawl fisheries targeting fish account for nearly 50% of global landings (Kelleher 2005). Demersal finfish trawling is second only to shrimp trawling in the quantity of global discards (1.7 million tons) but the global discard rate is substantially lower for demersal finfish trawling (9.6%, Kelleher 2005). The global average discard rate for pelagic trawling is 3.4%.

Observer data will be used to determine the status of fish stocks by complementing available survey data and to determine the extent of other bycatch.

6.3 List of Priorities

1. Collect information on fishing effort
2. Randomly sample catch for species composition
3. Record gear characteristics
4. Collect length-frequency data on target and non-target catch

6.4 Gear Description

Trawling is an active fishing method that involves pulling a cone-shaped net through the water behind one or more boats. Trawls can target fish and invertebrates on the bottom (demersal trawl) or in the water column (midwater or pelagic trawl; Figure 6-1). Trawl nets are designed and configured to accommodate specific target species and their unique behaviors; however, the two most common configurations hold the net open with either a rigid beam (beam trawl) or trawl doors (otter trawl; Figure 6-2). The doors (or otter boards) are hydrodynamically designed to open the net as it's pulled through the water.

As the trawl net is being towed (2-5 knots), fish are herded into the net opening by the wings. Fish pass through the body and are retained in the codend (Figure 6-3). These generalized sections are highly variable among vessels and you will need the crew/captain's assistance for gathering measurements and other information about the gear.

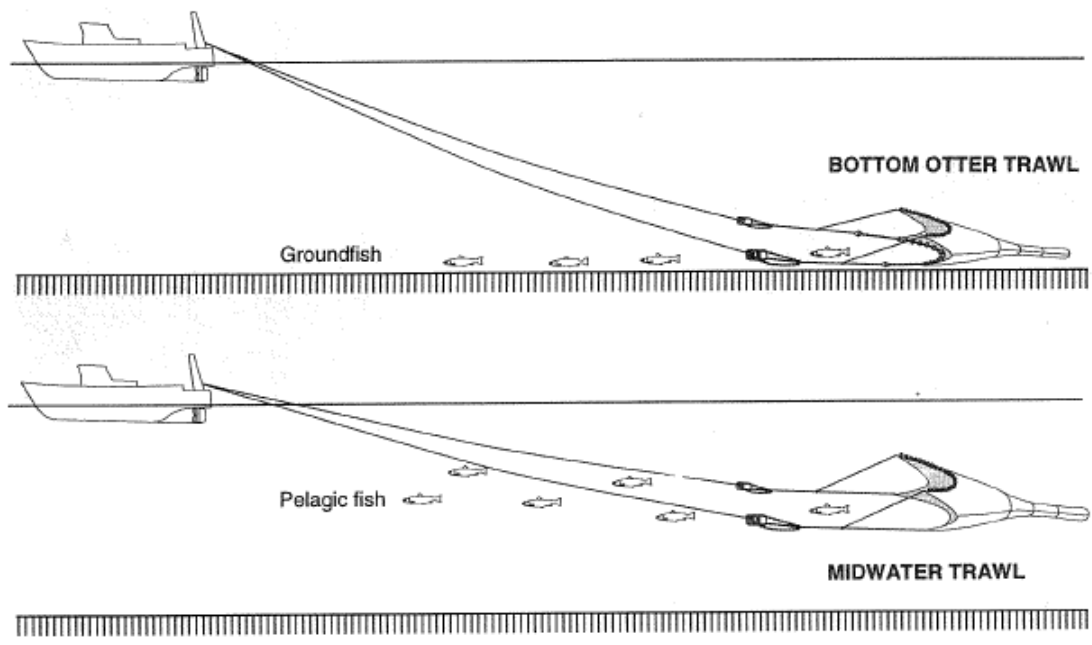
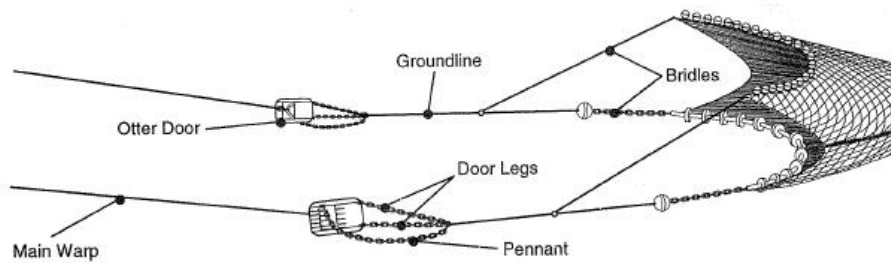

Figure 6-1 Bottom and midwater trawl nets target fish in different parts of the water column. Drawing from (Hanrahan et al. 1997).

A) Otter Trawl



B) Beam Trawl

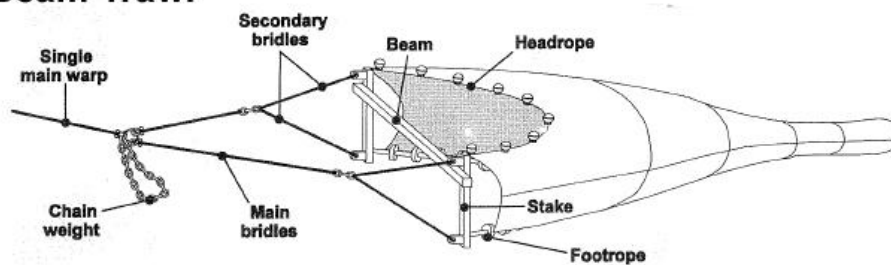

Figure 6-2 Otter (A) and beam (B) trawl configurations. The otter trawl in (A) is a bottom type trawl (note the rollers attached to the footrope). Drawing modified from (Hanrahan et al. 1997).

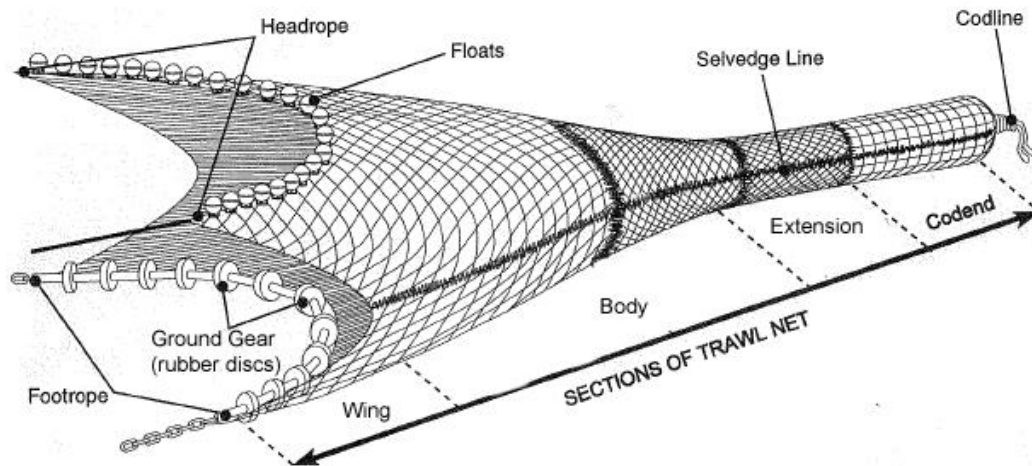

Figure 6-3 Generalized otter trawl net components. Net components are similar regardless of beam or otter trawl configuration. Drawing modified from (Hanrahan et al. 1997).

Gear deployment: The codend is lowered over the stern (or side) of the vessel and released into the water. Vessel speed is increased to create enough drag to pull the remainder of the net into the water. Bridles are then connected to the doors which are attached to the main warps or cables. The warps are set out until the trawl reaches the desired fishing depth. Once the trawl is deployed, the vessel is slowed to a preferred towing speed.

Gear retrieval: The haulback begins by winching in the main warps until the doors are at the stern. The pennants are removed from the doors and attached to the net reel transferring the strain from the warps to the net reel and groundline. The groundline and net are hauled back onto the net reel (Figure 6-4) until the ground gear is on board and the remainder of the net/codend is hoisted aboard in sections (side trawl) or all at once (stern trawl).

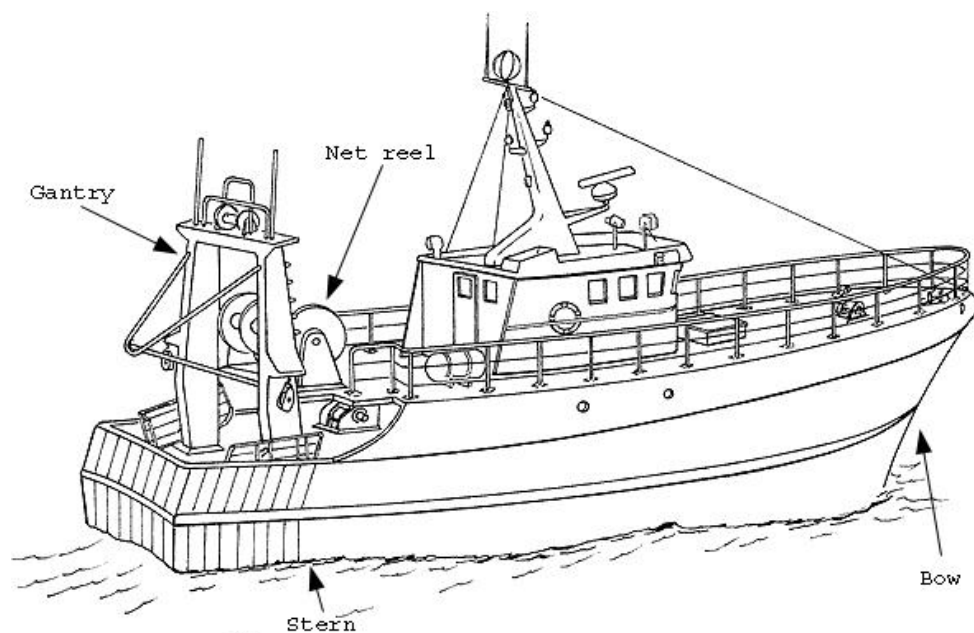

Figure 6-4 Mid-sized trawler configuration. Drawing modified from (FAO 1985).

6.5 Forms/Instructions

6.5.1 Gear Description – Finfish Trawl

Complete one form for each unique net (see example in Figure 6-9). If possible, complete before departure. Total number of pages equals total number of unique nets fished. Write your name on the first page.

Field	Definition
Observer Code:	Record your observer program identification code.
Vessel Code:	Record the vessel code (Appendix 3). If your vessel is not on this list, call the SOP immediately.
Trip ID	Enter the trip identification number assigned by the SOP.
Net type	Check the type of net: midwater or bottom
Net #	Record information on each uniquely configured net on board. If there is only one net, enter '1'.
Configuration	Check the type of trawl configuration: Otter trawl, beam trawl (Figure 6-2) or other. If other, draw diagram in comments section.
Net deployment position	Check the position where the net is deployed from: stern, port side or starboard side.
Net manufacturer / design name	Ask the captain for the name of the net manufacturer and model or design name.

Otter Trawl Section (Figure 6-2A)

Doors – Main & Dummy – The main doors may also be referred to as otter boards. The dummy door, or sledge, is used as a center door during twin trawl operations. If vessel fishing only 1 net, leave dummy door fields blank.

Material Circle the construction material of the doors.

Length & height Record the length and height of both door types in meters (Figure 6-5).

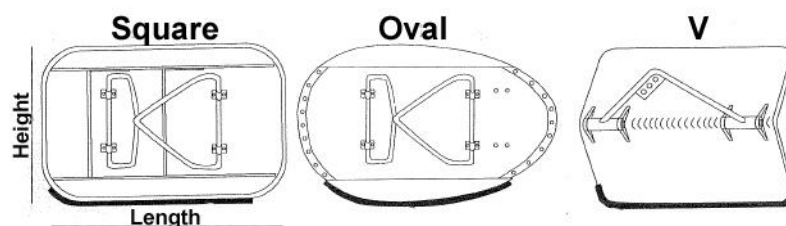

Figure 6-5 Door types and measurements. Drawing modified from (Hanrahan et al. 1997).

Weight Record the door weight in kilograms (from Captain).

Type Circle square, oval, V or other.

For each of the following components, record the length (meters), diameter (millimeters), material (e.g., iron chain for door legs and steel cable for bridle) and other information as necessary. For the various types of chain, record overall length (meters), diameter (mm; diagram below) and material.



Chain link diameter (Image from <http://www.mcmaster.com>).

Door legs Door legs, also known as back strops or back straps, connect the doors to the groundline. They also serve to keep the doors upright and stable during fishing operations.

Pennant The pennant is a loosely attached cable between the groundline and door which facilitates deployment and retrieval of the trawl. If absent, leave blank.

Groundline The groundline, or ground cable, connects the door legs to the bridle. If there is no groundline, leave blank.

Bridle The bridle connects the groundline to the net.

Beam Trawl Section (Figure 6-2B)

Beam & stake Record the length (m), weight (kg) and material (e.g., steel, aluminum, wood) of the main beam and the stakes.

For bridles and chain weights, record the length (meters), diameter (millimeters), material and other information as necessary.

Bridle (main) The bridle connects the doors to the warp (main cable to vessel).

Bridle (secondary-top) The top length of the secondary bridle is measured from the point of main bridle attachment to the top of the stakes.

Bridle (secondary-bottom) The bottom length of the secondary bridle is measured from the point of main bridle attachment to the bottom of the stakes.

Chain weight A chain weight can be attached to the front of the main bridle. Leave blank if not present. Provide total weight in ‘Other’ column.

Beam and Otter Trawl Section

For each of the following components, record the length (meters), diameter (millimeters), type of material (e.g., steel, poly, Spectra, or nylon) and other information as necessary.

- *Warp Warp (or main cable) connects the vessel to the otter trawl doors or beam trawl bridle. For otter trawl vessels, record the information for one side only (the assumption is both sides are the same).

- 3rd wire The 3rd wire cable connects the vessel to specialized net sonar equipment. The 3rd wire consists of a communications cable imbedded within an outer layer of steel cable. If absent, leave blank.

- Head rope Also known as head line, float line, or float rope. Record number of floats or headline kites attached to head rope and describe in 'Other' column.

- Foot rope Also known as lead line or ground rope.

- Selvedge line The seam along each side of the trawl that separates the top from the bottom.

- Tickler chain or ticklers The tickler chain or ticklers (smaller loops of chain) functions to dislodge or lift fish off the bottom and into the net. These are more common on shrimp trawlers.

Complete the next 5 fields on bottom trawl vessels only. Depending on the target species and bottom type (e.g., mud, rock), a variety of ground gears (or footgear) may be attached to the foot rope. Ground gear ensures close contact with the bottom and enables fishing on rough bottoms without damage to the trawl net (Løkkeborg 2005). Provide width (cm), diameter (cm), material and a count of how many for each ground gear component present. Ground gear images below from Hanrahan et al. (1997).

Metal
bobbins &
spacers

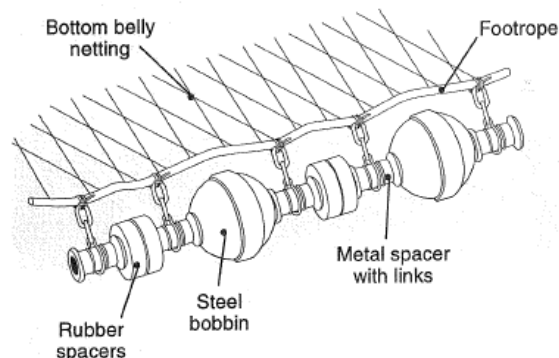

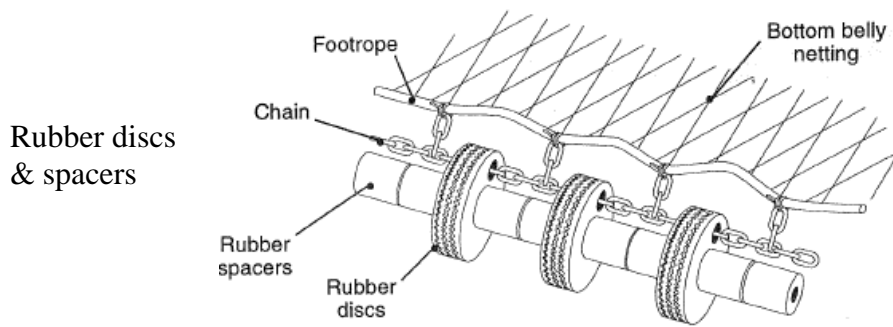

Net Characteristics Section

Most of the net specification will need to be obtained from the captain. Specifications indicated with an asterisk (*) should be measured by the observer.

Total length Record the total net length in meters. You will likely need to ask the captain.

Mouth width Record the mouth width in meters.



Mouth height Record the mouth height in meters.



Record the material type (e.g., nylon, poly, sapphire, or spectra), line or twine diameter (mm), stretched mesh opening (tenths of cm), indicate if mesh opening measurement was made when the gear was wet (W) or dry (D), count the number of meshes on the long or horizontal axis and the number of meshes around the net (vertical axis). Use a wedge gauge to measure the stretched mesh opening. Insert gauge with manual force in a direction perpendicular to the plane of the net and measure at least 20 meshes. Measure from inner knot to inner knot (Figure 6-6). Mesh may be hung in either diamond or square configuration which impacts fish (and bycatch) catch rates (Figure 6-7); circle the diamond or square for how the codend mesh is hung.

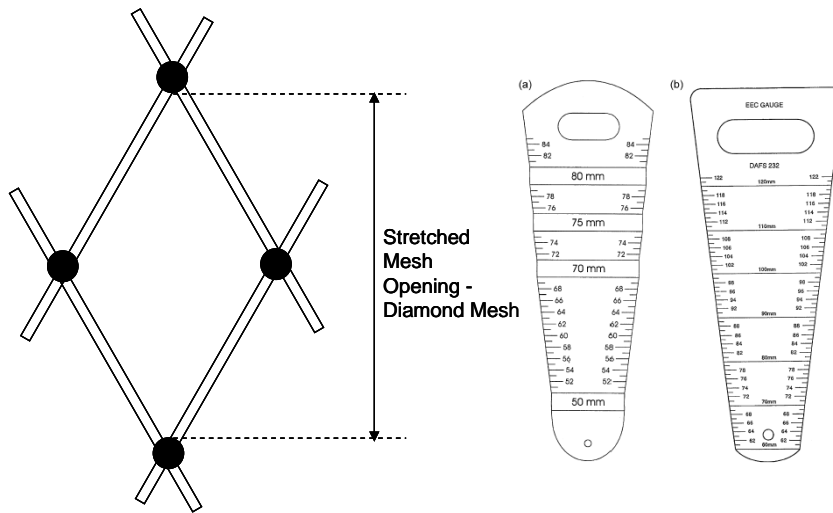

Figure 6-6 Measure stretched mesh opening from the inner edge of knots (upper left; modified from Ferro and Xu 1996) using a wedge gauge (upper right; Fonteyne et al. 2007). Bottom image supplied by S. Sei (Sierra Leone).

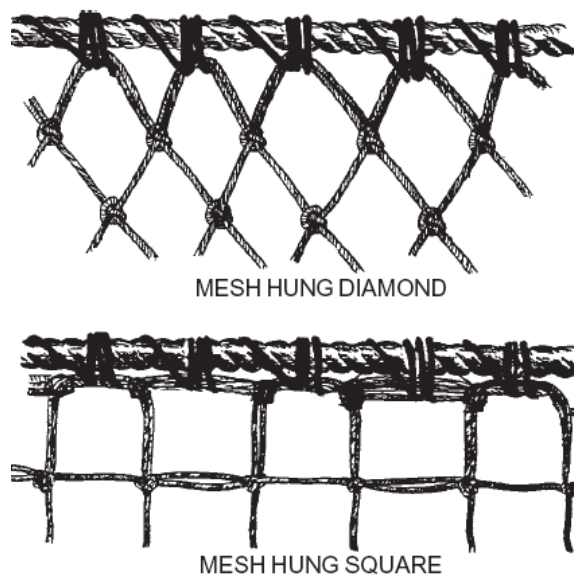

Figure 6-7 Mesh can be hung in diamond (top) and square (bottom) configuration. Drawing from (NMFS 2007b).

Wing	Sections of netting at the foremost part of the net which define the outer perimeter of the trawl opening. The wings maintain the shape of the trawl and herd fish into the net opening.
Trawl body	May be referred to as square and belly. If this section tapers, record the range of mesh sizes.
Extension	The extension, or lengthening piece, is a section between the body and the codend and is used to extend the overall length of the trawl. If extension isn't present, leave fields blank.
Codend	<p>The codend, or bag, is the section that collects the fish. Circle the diamond or square for how the codend mesh is hung relative to the selvedge line.</p> <p>*Codend mesh opening should be measured independently using the wedge gauge issued. Push wedge into stretched mesh opening and apply consistent force (~5kg). Measure 10 meshes and record in the comments field. Calculate the average mesh opening size and record on the form.</p>
Other	Record any other types of mesh sections not already recorded (e.g., codend liners).
Other rigging present.	<p>Check each additional rigging component that is present on the net.</p> <p>Chaffing gear can be pieces of line or extra webbing attached to the codend to protect it from damage.</p> <p>Elephant ears are sewn to the end of the net in order to evenly distribute the lifted weight.</p> <p>Lazy line used to lift and maneuver the net (Figure 6-8) and is sometimes attached to the elephant ears.</p> <p>Strengthening straps can be vertical (transverse) or horizontal (lastridges; Figure 6-8). Vertical straps encircle the codend to reinforce the mesh strength. These straps are not attached directly to the meshes but are fed through loops of twine at intervals around the net. Similarly, horizontal straps (parallel to the selvedge line) also serve to strengthen the codend.</p>

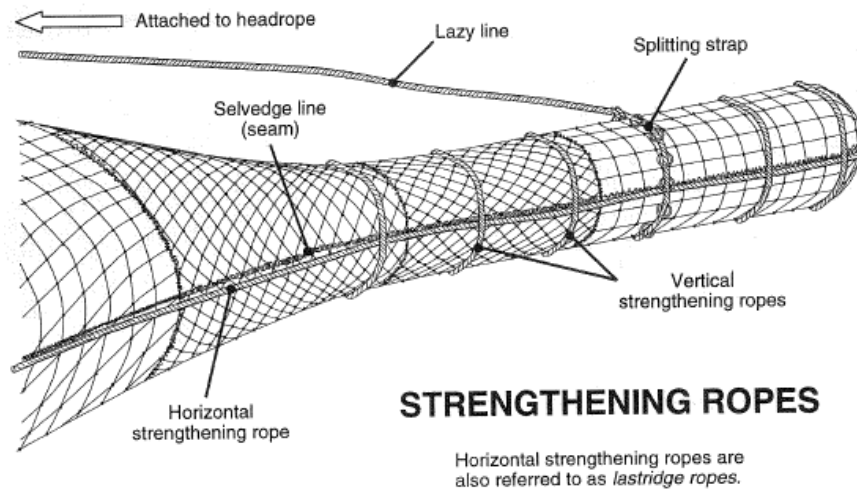

Figure 6-8 Types of strengthening ropes. Drawing from Hanrahan et al.(1997).

The **splitting strap** is used to bring consistent sized portions (splits) of catch on board, usually lifted from one side of the vessel.

Add any other gear and make detailed comments in the comments field at the end of the form.

Photos? Circle **Yes**, if photos were taken of any gear component. Remember to provide copies to your debriefer and record detail in the Photo Log of the Observer Logbook.

Bycatch Reduction Device (BRD)

If there is no BRD, leave this section blank. A more detailed discussion of BRDs can be found in Chapter 7.

Type	Check BRD type. Fisheye, Radial escape section, Square-mesh window, Square-mesh codend, or other (specify in space provided).
Funnel	Check Yes or No for the presence of a herding funnel/cone.
Distance from escape opening to headrope	Measure in meters.
Distance from escape opening to tie off rings	Measure in meters.
Fisheye Offset	Number of meshes offset from top center. If located at top, enter "0"
Opening height	Measure in cm

& width

Shape Check appropriate opening shape: oval, diamond, square, halfmoon, rectangle, triangle, or specify if other.

Radial escape section

Opening width, Measure applicable dimensions in cm
height, length

openings If the radial escape section isn't continuous around the codend, record the number of openings.

Square mesh window

Opening width, Measure applicable dimensions in cm
height, length

BRD Provide additional notes and draw a diagram.
notes/drawing

Comments Record any additional comments or make drawings about the gear here.

Gear Description - Finfish Trawl

Observer code 175		Vessel code X'YZ 3856		Trip ID 00275	
Net type (check one):		Midwater <input checked="" type="checkbox"/>	Bottom <input type="checkbox"/>	Net #: 1	
Configuration (check one):		<input checked="" type="checkbox"/> Otter trawl	<input type="checkbox"/> Beam trawl	Other _____	
Net deployment position (check one):		<input checked="" type="checkbox"/> Stern	<input type="checkbox"/> Port	<input type="checkbox"/> Stbd	
Net Manufacturer / design name: <u>Africa Net Systems / Flatfish Special</u>					
Otter Trawl					
Doors - Main			Doors - Dummy		
Material:	Aluminum / (Steel) / Wood / Other _____		Material:	Aluminum / Steel / Wood / Other _____	
Length (m)	1.4	Height (m)	1	Length (m)	
Weight (kg)	800	Type	Square / (Oval) / Other _____	Weight (kg)	
	Length (m)	Diameter (mm)	Material	Other	
Door legs - top	2.1	5	Chain		
Door legs - bottom	2	5	Chain		
Penant	3.2	5	Chain		
Groundline	4	12	Stainless steel		
Bridle (top leg)	5	12	Stainless steel		
Bridle (bottom leg)	4	12	Stainless steel		
Beam Trawl					
	Length (m)	Weight (kg)	Material	Other	
Beam					
Stake					
	Length (m)	Diameter (mm)	Material	Other	
Bridle (main)					
Bridle (secondary-top)					
Bridle (secondary-bottom)					
Chain weight				Weight:	
Otter and Beam Trawl					
	Length (m)	Diam (mm)	Material	Other	
Warp	500	12.5	Stainless steel		
3rd wire	600	5	Stainless steel		
Head rope	35	8	Polyethylene	# floats: 15	
Foot rope	30	8	Polyethylene		
Selvedge line					
Tickler chain				Weight:	
Other					

Gear Description - Finfish Trawl

	Width (cm)	Diam (cm)	Material	Other			
Metal bobbins				How many?			
Metal spacers				How many?			
Rubber discs	5	20	<i>Rubber</i>	How many? 10			
Rubber spacer	5	12	<i>Rubber</i>	How many? 24			
Other							
Net Characteristics							
Total length (m): 21		Mouth width: 15			Mouth height: 2		
	Material	Diam. (mm)	Mesh open (cm)	W / D	# meshes long	# meshes around	Other
Wing	<i>Poly</i>	4	10	W	60	30	
Trawl body	<i>Poly</i>	4	6	W	80	40	
Extension	<i>Ultra Cross® knotless</i>	4	6	W	80	40	
Codend	<i>Ultra Cross® knotless</i>	4	4.5	W	120	70	◊ / □
Other							
Other							
Other rigging present? Check all that apply.							
<input checked="" type="checkbox"/>	Chaffing gear	<input type="checkbox"/>	Vert.Streng.Strap	<input type="checkbox"/>	Lazy line	<input type="checkbox"/>	Other:
<input type="checkbox"/>	Elephant ears	<input type="checkbox"/>	Horiz.Streng.Strap	<input type="checkbox"/>		<input type="checkbox"/>	Other:
<input type="checkbox"/>		<input type="checkbox"/>	Splitting Strap	<input type="checkbox"/>		<input type="checkbox"/>	
Photos? Y / <input checked="" type="radio"/> N							
Bycatch Reduction Device (BRD)							
Type: <input type="checkbox"/> Fisheye		<input type="checkbox"/> Square-mesh window		<input type="checkbox"/> Other:			
<input type="checkbox"/> Radial escape section		<input type="checkbox"/> Square-mesh codend					
Funnel	<input type="checkbox"/> Yes	Distance of escape opening from headrope:				<input type="text"/> m	
	<input type="checkbox"/> No	Distance of escape opening from tie off rings:				<input type="text"/> m	
Fisheye		Offset		Radial escape section			
Opening (cm)	Width <input type="text"/>	Height <input type="text"/>		Opening (cm)	Width <input type="text"/>	Height <input type="text"/>	
Shape				Length <input type="text"/>			
<input type="checkbox"/> Oval	<input type="checkbox"/> Diamond			If not all the way around, #openings <input type="text"/>			
<input type="checkbox"/> Square	<input type="checkbox"/> Halfmoon						
<input type="checkbox"/> Rectangle	<input type="checkbox"/> Triangle						
<input type="checkbox"/> Other:				Square-mesh window			
				Opening (cm)	Width <input type="text"/>	Height <input type="text"/>	
BRD notes/drawing							
Comments: <i>Codend mesh average: (4.5+4.55+4.45+4.5+4.5+4.45+4.4+4.5+4.6+4.55)/10 = 4.5 cm</i>							

Figure 6-9 Example Gear Description Form.

6.5.2 Trawl Effort / Total Catch Form

An entry is made on the Trawl Effort / Total Catch form for each non-fishing day and for each haul made during the trip regardless of whether the haul was sampled for species composition. Note that for a given haul, the fields for date/time, position and depth are split for start and end entries (Figure 6-12). Pages are numbered consecutively for each trip. For fields that remain the same over time, down arrows are acceptable.

Field	Definition
Observer Code:	Record your observer program identification code.
Vessel Code:	Record the vessel code (Appendix 3). If your vessel is not on this list, call the SOP immediately.
Trip ID	Enter the trip identification number (assigned by the program prior to each trip).
Haul	Record haul numbers sequentially for the trip. You can start at "1" or use the same numbering system as the captain but you must include hauls with zero catch. Enter "0" for all non-fishing days and enter a time and position for this day.
Total nets	Record the how many nets fished (e.g., 1, 2 or 4) during a haul. For shrimp this excludes the try net. For finfish, this will typically be "1".
Gear Perf	Record the appropriate code for gear performance: <ol style="list-style-type: none"> 1. No problem 2. Net spread issues (door- and warp-related problems) 3. Net not fishing (bogged, obstructed, bag untied, torn, etc) 4. Net lost 5. Other <p>For performance #2-5, document details about the problem in the Observer Logbook.</p>
Sampled?	Check box if a catch composition sample was collected for this haul
Target	Record the intended target species: S – Shrimp F – Fish
Substrate	Record the dominant substrate using the following categories modified from Longhurst (1965): <ul style="list-style-type: none"> M – Mud S – Sand R – Rocky C – Corals CM – Corals and mud

CMS – Corals, mud and sand

Ask the captain for assistance.

Date Record start and end date for each haul (note that start and end are recorded on separate rows). There is a separate column for day, month and year. Record 2-digits in each column. If non-fishing day, enter date in the start row only.

Time (24-hr) Record fishing start and end time for each haul using 24-hr notation (e.g., 8:45 a.m. = 0845 and 2:12 p.m. = 1412). Start time is defined as the time winches are locked into place and gear is ‘on bottom’ fishing (Figure 6-10). End time begins when gear is lifted off bottom and is on its way up. If non-fishing day, record the time the position was recorded for this day.

If the vessel does not maintain a detailed fishing log, you may need to coordinate the recording of time and position with the captain for hauls when you are sleeping.

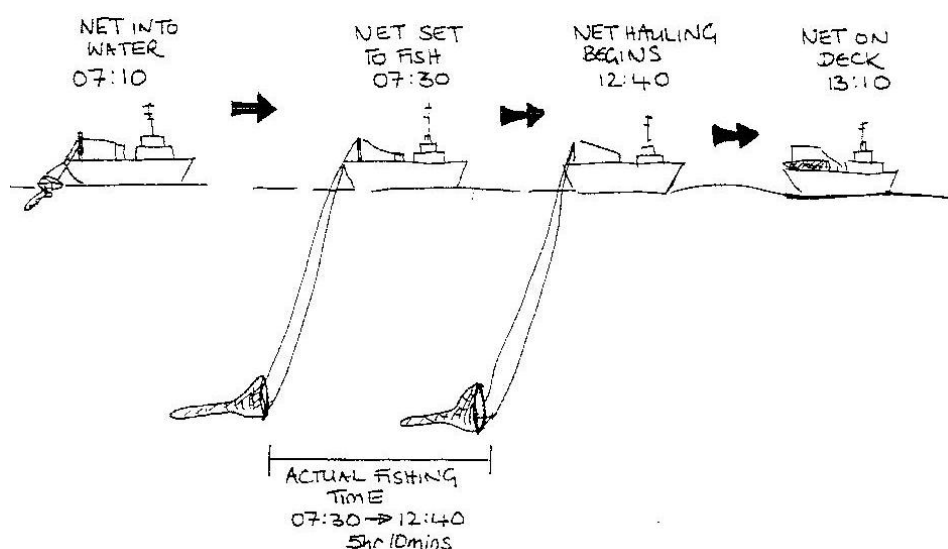

Figure 6-10 Diagram of fishing times. Figure from Davies and Lesch (1998).

Lat-Deg Record degrees of latitude (2-digits) for start and end of each haul.

Lat-Min Record the minutes of latitude (to hundredths of a minute; 4-digits)

Lat-N/S Record **N** for all latitudes North of the equator and **S** for latitudes south of the equator. Cameroon waters are north of the equator.

Long-Deg Record degrees of longitude (3-digits) for start and end of each haul.

Long- Record the minutes of longitude (to hundredths of a minute; 4-digits)

Min

Long-
E/W Record **W** for all longitude West of the prime meridian (e.g., 0°) and **E** for longitudes east of the prime meridian. Cameroon waters are east of the prime meridian.

Depth
(bottom) Record the bottom depth (meters; Figure 6-11) at the start and end of each haul.

Depth
(fishing) Record the fishing depth (meters; Figure 6-11) at the start and end of each haul. Fishing depth should be less than or equal to bottom depth. For demersal gear, record fishing depth as bottom depth minus ½ net mouth height (to nearest whole number).

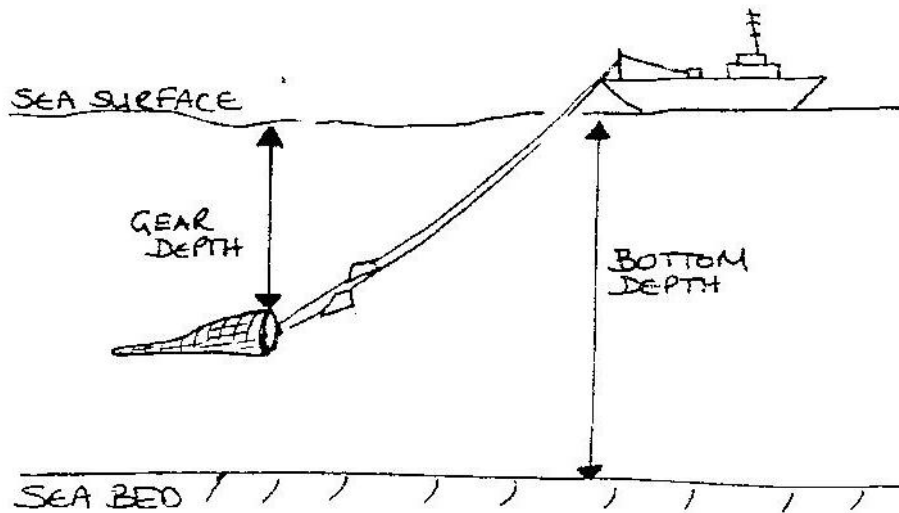

Figure 6-11 Diagram of gear and bottom depth. Figure from Davies and Lesch (1998).

V / O Record **O** if the observer independently recorded time, position and depth information from the appropriate device. Record **V** if the information was obtained from a vessel's fishing log or the captain.

Sea state Record the dominant sea state during this haul. Sea state definitions are explained in Appendix 12.

Speed Record the average towing speed (knots). Obtain from captain.

Catch
Estimate Record the Catch Estimate for total catch in metric tons. See next section for a more detailed explanation of catch estimation methods.

Method Record code for the catch estimation method used:

1. Weigh entire catch
2. Weighed subsample and extrapolated to total basket count
3. Volumetric estimate: bin or codend
4. Catch/effort ratio
5. Captain/Vessel estimate

6. Other method used. Document method in observer logbook.

Observer code		175		Vessel code		XYZ 3856		Trip ID		00275													
		Date/Time			Position																		
Haul	Total nets	Gear Perf	Sampled?	Target	Substrate	Day	Month	Year	Time (24-hr)	Lat-Deg	Lat-Min	Lat-N/S	Long-Deg	Long-Min	Long-E/W	Depth (bottom)	Depth (fishing)	V / O	Sea state	Speed	Catch Estimate	Method	
0						Start	10	11	09	1110	8	29.0	N	13	14.0	W							
						End						N											
0						Start	11	11	09	1110	7	58.3	N	14	1.1	W							
						End						N											
1	1	1		F	S	Start	12	11	09	0010	7	34.1	N	14	14.0	W	30	29	O				
						End	12	11	09	0237	7	29.0	N	14	14.0	W	32	31	O	2	2.5	5.00	5
2	1	1	x	F	S	Start	12	11	09	0315	7	29.0	N	14	14.0	W	34	33	O				
						End	12	11	09	0833	7	29.0	N	14	14.0	W	34	33	O	2	2.5	4.50	5
3	1	1	x	F	M	Start	12	11	09	1005	7	29.0	N	14	14.0	W	37	36	O				
						End	13	11	09	1444	7	29.0	N	14	14.0	W	34	33	W	3	2.5	6.33	3
0						Start	13	11	09	1200	7	0.0	N	14	14.0	W							
						End						N											
4	1	1	x	F	M	Start	13	11	09	2257	6	58.3	N	14	14.0	W	44	43	O				
						End	14	11	09	0140	6	58.4	N	14	14.0	W	50	49	W	4	2.5	4.78	3
5	1	3	x	F	M	Start	14	11	09	0325	6	58.3	N	14	14.0	W	45	44	O				
						End	14	11	09	0635	6	58.6	N	14	14.0	W	44	43	O	3	2.5	3.24	3
6	1	1		F	M	Start	14	11	09	1008	6	57.8	N	14	14.0	W	68	67	W				
						End	14	11	09	1320	6	58.3	N	14	14.0	W	65	64	W	2	2.5	4.00	5
						Start						N											
						End						N											
Gear performance codes:						Target:						Total Catch method:											
1. No problem						S – Shrimp F – Fish						1. Weigh entire catch											
2. Net spread issues (door- and warp-related problems)						Substrate:						2. Weigh subsample & extrapolate to total basket count											
3. Net not fishing (bogged, obstructed, bag untied, torn, etc)						M – Mud S – Sand						3. Volumetric estimate: Bin or codend											
4. Net lost						R – Rocky C – Corals						4. Catch / effort ratio											
5. Other						CM – Corals & mud						5. Captain / Vessel estimate											
						CMS – Corals, mud & sand						6. Other											

Figure 6-12 Example Trawl Effort / Total Catch form.

6.6 Total Catch Estimation

6.6.1 Methods of Total Catch Weight Estimation

NOTE: This section is written assuming a basket weight of ~25kg. If actual basket weights are different, you will need to modify the basket numbers discussed below accordingly.

The method employed to estimate total catch on finfish and shrimp trawl vessels depends on total catch size. There are five options:

1. Weigh entire catch (small catch, ~400 kg, <16 baskets) before or after sorting. This will be the most common method for shrimp trawl where total catch will equal retained plus discard weight;
2. Weigh subsample of catch, tally total baskets and extrapolate to total catch using average basket weight (moderate catch, ~400-750kg, 16-30 baskets). For large shrimp catches, you may use this method for estimating total discard weight;
3. Volumetric estimate: Bin or codend (large catch and unable to fill baskets and tally);
4. Catch/effort ratio – At times you will be unable to be on deck when a net comes on board. Use the ratio of catch and effort from similar hauls to estimate total catch.
5. Captain/vessel estimate – this is the least desirable method.
6. Other – if you use some other method, contact the observer program with details on method. Document the method in the Observer Logbook.

Each option is discussed in more detail below and follows the numbered steps in the flow chart for total catch estimation (Figure 6-13). When the observer is not on deck (e.g., you may be asleep), there are two choices for estimating total catch.

1. Have similar tows been made? ‘Similar’ can be defined as having the same depth strata in the same area and similar retained composition.

1A. If yes, calculate a catch/effort ratio using the following formula.

$(\Sigma \text{ Total weight of similar hauls} / \Sigma \text{ Haul duration of similar hauls}) * \text{Haul duration of unknown haul} = \text{Estimated weight of unknown haul}$

For example, given the following haul info:

<i>Haul</i>	<i>Total WT</i>	<i>Start time</i>	<i>End time</i>	<i>Haul duration</i>
1	1.32	0025	0340	195
2	2.35	0400	0812	252
3	1.89	0842	1205	203
4	X	1228	1545	197

*Then X = ((1.32+2.35+1.89)/(195+252+203)) * 197*

*X = (5.56/650) * 197 = 0.008554 * 197 = 1.685108 ≈ 1.69 MT*

1B. If no, use the captain’s estimate of total catch and document why this method was used in the Observer Logbook.

When observer is on deck, there are three choices for estimating total catch.

2. Determine approximate size of catch and categorize into one of the three options. This is a rough estimate of how many 25-kg baskets the total catch will fill.

2A. Catch is small (<400 kg or < 16 baskets) - weigh entire catch. Catch may be sorted in advance or sorted after weighing.

- i. Shovel all catch into baskets.
- ii. Weigh each basket and record weights.
- iii. Sum all weights & record total weight estimate on Trawl Effort / Total Catch form. Record all weights and calculations in the Observer Logbook. Go to #3 on flowchart.

2B. Catch is moderate size (400-750kg or 16-30 baskets).

- i. Shovel all unsorted catch into baskets. Fill each basket to approximately the same height.
- ii. Weigh 10 baskets and record weights. Count remaining baskets.
- iii. Calculate average weight from weighed baskets (i.e., sum all weights/total # baskets weighed). Multiply the total count of baskets by the average weight & record total weight estimate on Trawl Effort / Total Catch form. Record all calculations in the observer logbook. Go to #3.

2C. Catch is large (>750 kg or >30 baskets). Volumetric estimate may be most appropriate. Multiply total volume by density. Go to #3.

3. Are you taking a catch composition sample for this haul?

3A. If no, this haul is complete.

3B. If yes, go to #4 (see Catch Composition section - Figure 6-18).

Potential issues to be aware of when estimating total catch and sampling catch composition (Pauly 1984):

- Dangerous or other ‘protected species’ may be removed prior to sorting. Record number, species, estimated weight and any other relevant information. If a sea turtle is caught, you may need to quickly collect your catch composition sample (set aside), process the turtle and then process the catch composition sample.
- Inorganic debris & plant material may be removed prior to total catch estimate. Record type and weight of material removed.
- Large fish may be removed by crew prior to making total catch estimate. Try to identify, count how many were removed and estimate weight. Remember to include this weight in total weight estimate and on catch composition form as sample type ‘1’ for Whole haul sampling or sample type “7” for other fish removed.

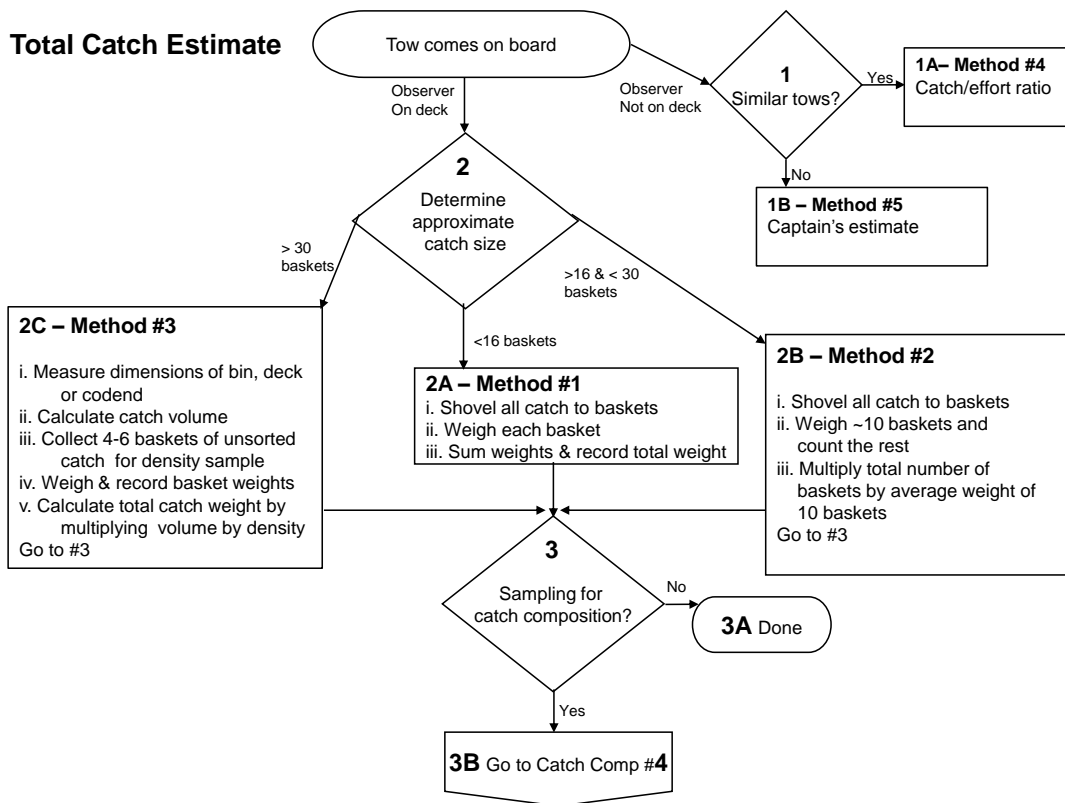

Figure 6-13 Flow chart of total catch estimation procedure.

6.6.1.1 Bin Volumes

Total catch is estimated by bin volume when all of the catch is dumped into one or more measurable areas on the deck or within holding bins below deck. Volumes are calculated using the measurements (length, width, and height) of those bins. Multiply bin volume by density (Section 6.6.1.3) to calculate total weight estimate. Bin volumes become problematic when the bin is full of water.

Steps and tips for calculating bin volumes:

- **Determine the appropriate volume formula for each area of the bins and/or trawl alley.** Many bins and trawl alleys will be rectangular (Figure 6-14); however, some will have odd shaped areas (Figure 6-15). Common formulas are listed in Appendix 10.
- **Measure the area of the empty bins and trawl alley in meters.** It is easiest to measure the area of the bins and trawl alley prior to leaving the dock. If the bins and trawl alley have easily definable sections, measure them independently. Often, a catch only fills up a portion of the total area. **Draw the trawl alley and bins in the Observer Logbook and document the measurements of each area.** From these measurements, the total area of the bin will be available.
- **Measure the height of the catch in the bin in meters.** The height of the fish in the bin provides the final dimension needed to obtain the volume of the catch. Height is measured by placing a calibrated stick into the bin to measure the depth of fish at one or several points. If the height of fish varies throughout the bin, multiple height measurements should be taken and an average height calculated:

Average Height = Height A + Height B + Height C ... / # height measurements

- **Calculate and record catch volume.** Record measurements on your deck sheet. Make sure that all of the measurements are as precise as possible. Calculations will be recorded in the Observer Logbook. To obtain volume of the catch:

Volume of catch = total area of bin * average height

- **Calculate total catch estimate.** Multiply the volume by the density to calculate the Total catch weight estimate:

Total weight estimate = volume of catch * density

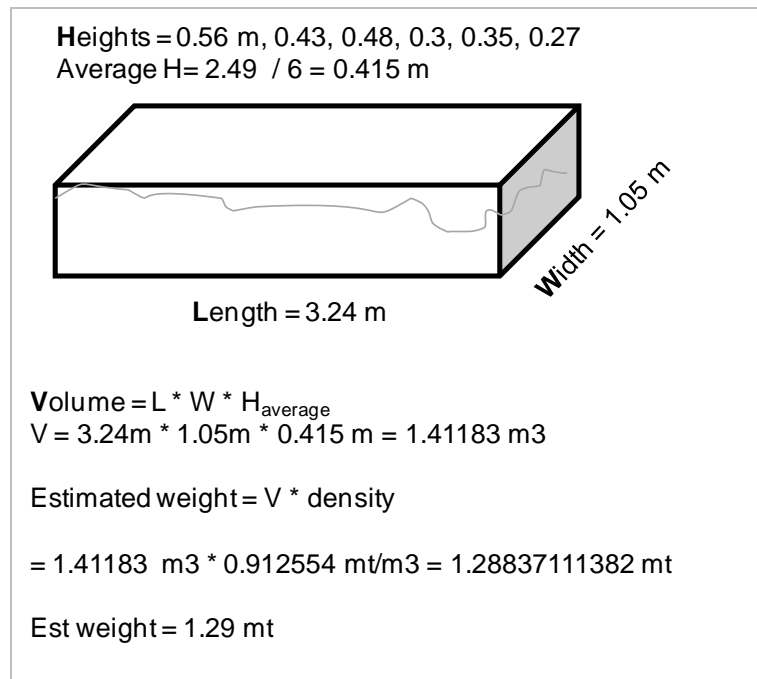

Figure 6-14 Bin volume calculation using six heights – light grey line is approximate height of fish in bin.

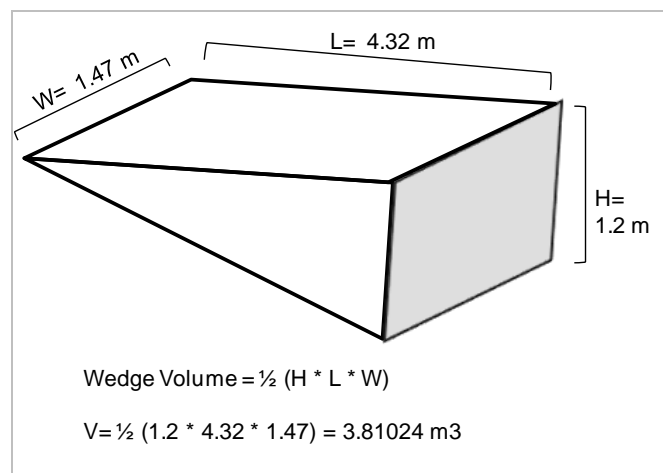

Figure 6-15 Calculation example for wedge volume.

6.6.1.2 Codend Volume

Similar to bin volume, codend measurements (length, width, and height) are made to calculate a volume of the codend. Codend volume is sometimes more difficult to calculate due to very complex shapes. Multiply volume by density to calculate total weight estimate.

When measuring a codend, always remember that safety is the first concern. Nets can slide and roll. Be careful not to get caught between the net and the trawl alley bin boards. Ask crew members for assistance; their help will make the task easier and safer. Follow the steps below to take an accurate codend measurement.

- **Determine the appropriate geometric shape(s) and decide on the appropriate formula(s) to use.** Using the formula, determine which dimensions will be measured

in order to obtain a volume. Refer to Appendix 10 for the formulas required to calculate the various volumetric shapes.

- **Measure the various dimensions of the codend using actual measurements and/or reference points.** Take height and width measurements from several segments to obtain an average height and width for the net. It may be necessary to acquire a long stick, or a similar item, and mark it for use as a height gauge. When sighting across the net for a height, the observer’s eyes should be level with the top of the net.
- **On the deck sheet, record the method and dimensions and in the Observer Logbook, record the formulas and calculations used in obtaining the volumetric estimate.** Most measurable codends require the use of the ellipsoidal formula (Figure 6-16).

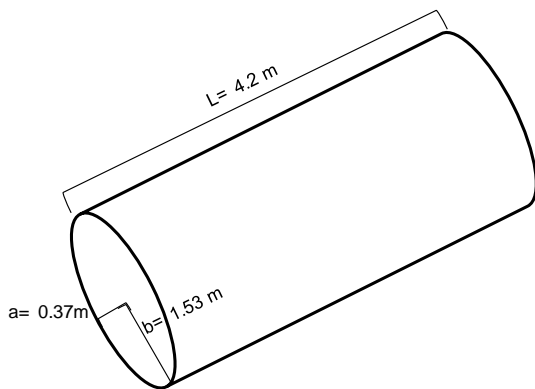

Ellipsoidal Solid
 $V = \pi * \text{short radius} * \text{long radius} * \text{length}$
 $V = \pi * a * b * L$
 $V = \pi * .37 \text{ m} * 1.53 \text{ m} * 4.2 \text{ m}$
 $V = 7.469513 \text{ m}^3$

Figure 6-16 Volume calculation for ellipsoidal solid. Pi (π) is a mathematical constant = 3.14159.

- **Calculate total catch estimate.** Multiply the volume by the density to calculate the Total catch weight estimate:

Total weight estimate = volume of catch * density

Measuring Large Codends

Occasionally, a full codend is larger than the trawl deck and must be brought on board and emptied in several sections. To determine the codend volume in this situation, measure the codend sections as they are brought on-board. Use the reinforcing cables, or “expansion straps”, around the circumference to divide the codend into sections. Determine a volume for each segment of the net measured and add them together for a total volume of the codend. **Do not** apply a predetermined or constant volume to the number of codend segments to calculate the total catch estimate.

6.6.1.3 Density sampling

The density of fish can be calculated using a small container/sampling basket. Density is calculated by dividing the basket weight by the volume of the fish in the basket. If more than one basket is collected for a density sample (highly recommended for larger catches), divide the sum of weight by the sum of volume to get density. If you use the same basket type, you

will save time by filling to the same height so that the basket volume is standardized. Then all you need to do is collect the weights (Figure 6-17).

$$\text{Density} = \text{Weight (mt)} / \text{volume (m}^3\text{)} = \Sigma \text{ basket weights} / \Sigma \text{ basket volumes}$$

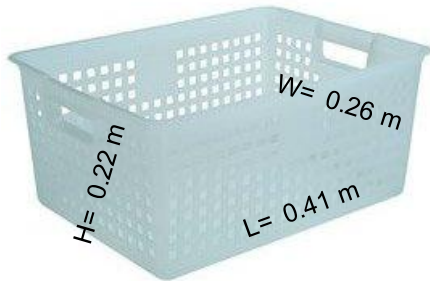

Basket weights (all filled to bottom of handle): 24.3 kg, 20.7 kg, 21 kg, 22.9 kg, 22.7 kg, 23 kg

$$\text{Basket volume} = L * W * H$$

$$V = 0.41 * 0.26 * 0.22$$

$$V = 0.023452 \text{ m}^3$$

$$\text{Density } (\rho) = \text{mass (mt)} / V \text{ (m}^3\text{)}$$

$$\rho = .1346 \text{ mt} / (0.023452 \text{ m}^3 * 6)$$

$$\rho = .1346 \text{ mt} / (0.140712 \text{ m}^3)$$

$$\rho = 0.95656376 \text{ mt/m}^3$$

Figure 6-17 Density calculation example.

6.7 Catch Composition Sampling

6.7.1 Diversity of Fleet and Effects on Sampling

Although vessel characteristics and target species make the fleet diverse, sampling protocols are consistent for all trawl vessels. In general, there are a number of vessel characteristics that influence catch sampling including:

Trawl vessels range from 15 to 100 meters

Vessel size – The size and layout of a vessel is often a limiting factor when sampling. A vessel with a small deck may not have enough deck space to hold all discards. Therefore, the vessel may sort the discard directly out a scupper, over the side or down the stern ramp. On small vessels, observers may not have a designated sample area or a sample area with much space.

Duration of tow – Tow duration can vary greatly. If a vessel is making long tows, over 3 hours, observers will have plenty of time to sort and weigh samples. Observers on vessels that haul every hour have a limited amount of time to complete sampling duties.

Tow duration ranges from 3 to 5 hours for shrimp & 1 to 6 hours for finfish.

Total catch ranges from 200 to 800 kg for shrimp and from 500 to 5000 kg for finfish.

Size of total catch – Vessel size and size of total catch are related. Problems are created when a small vessel has a large tow because there is very little room for the work up of samples. It can also create a dangerous working environment.

Composition of tows – Most tows encountered will have a large diversity of species. This is not necessarily a problem for experienced observers that are able to identify species easily. However, the species composition of the tow will affect the sample size. If the vessel has a codend full of tiny juvenile fish, it may be necessary to reduce the sample size.

Trawl tows can have as few as 20 to >50 species.

Sorting technique of crew– Each vessel will have a unique sorting method. Talk with the crew prior to the first haul to discuss how they sort and the best way to collect the samples.

All of the factors above are interrelated. For example, if a small vessel has short tow duration and tows are large, how the combinations of these factors affect sampling options needs to be considered.

Types of crew sorting on trawl vessels:

1. Crew sorts retained into bins or baskets while leaving discard on deck.
2. Crew sorts out a scupper-retained fish are taken out of the flow of fish while discards are flushed directly off the vessel.
3. Crew sorts retained into bins or baskets and tosses or scoops discard overboard.
4. Crew presorts certain species.
5. Crew sorts from chute that discards

Once your sample is in hand, follow the steps below (and Figure 6-18) to process the catch composition sample (This list continues from steps listed under Total Catch Estimation methods):

4. Was total catch estimated using 1A/1B or 1C?
 - 4A. If 2A/2B, randomly select 1-2 baskets. For shrimp trawls, remember to record which net was sampled. Go to 4B.
 - 4B. If 4C & have unsorted sample, sort the entire sample into smaller baskets by species or species group. Go to #5.
5. Is this a species on the length collection list? It's a good idea to clear the target species first.
 - 5A. Yes
 - i. Count and weigh each species.
 - ii. Estimate the proportion retained for each spp.
 - iii. Randomly collect 20 'specimen' and determine gender & measure lengths
 - iv. Return target species to crew for processing & discard non-retained species.
Go to #6
 - 5B No
 - i. Count and weigh each species.
 - ii. Estimate the proportion retained for each spp.
 - iii. Return target species to crew for processing & discard non-retained species.
Go to #6
6. Do you have more species left to sample?
 - 6A Yes, return to #5
 - 6B No, DONE!

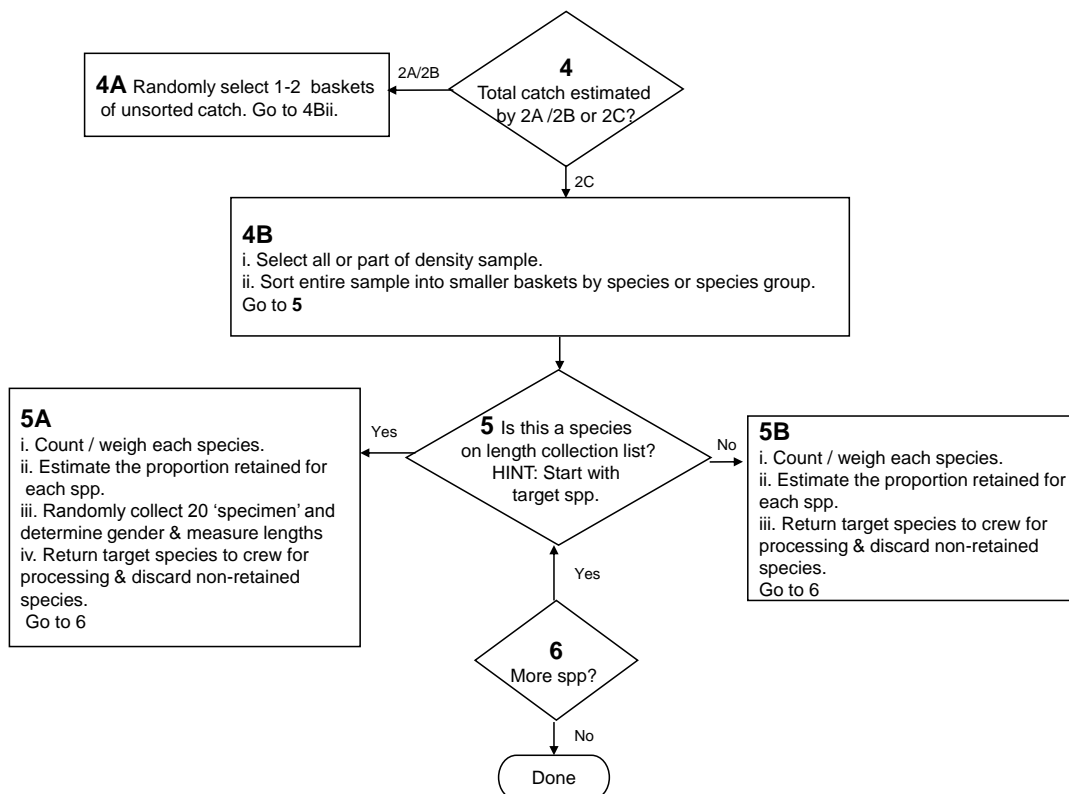

Species Composition

Figure 6-18 Flow chart of species composition sampling procedure.

Helpful hints:

- Remember to include any items or specimen removed prior to taking the catch composition sample on the catch composition form as sample type '1'.
- If the vessel is changing nets throughout a trip, it may be helpful to mark nets for easy identification
- If nets are normally mixed, establish a plan for separating catch from each net early in the trip.

6.7.2 Haul Selection

Depending on the number of hauls made per day, it may be physically impossible to sample all hauls. Therefore, random sample tables (RST) have been developed so that hauls are selected at random. There are two RSTs set up for different situations (Table 6-1). RST#1 is set up to sample 2 or 3 hauls in a row followed by one 'off' or unsampled haul. The haul sampling rate for RST#1 is ~70-72%. RST#2 is set up to sample 2 to 4 hauls in a row with one or two 'off' or unsampled hauls between. The haul sampling rate for RST#2 is ~65-70%.

Table 6-1 Guidelines for choosing a Random Sample Table

Hauls/day	Random sample table
1-2	None – Sample all hauls
3-4	RST#1
5+	RST#2

Catch composition is recorded on the generic Catch Composition form described in Chapter 5.

6.8 *Biological Data*

If assigned length collection, follow protocol provided at that time. There is also additional information in each gear-specific chapter.

7 Trawl – Shrimp

7.1 Learning objectives

- Describe the difference between a pair trawl and a twin trawl
- Describe two methods to estimate total catch.
- List the 3 forms that are specific to shrimp trawlers
- Explain why BRDs are used.

7.2 Introduction

Shrimp trawling is one of the most important fisheries in the Gulf of Guinea system. However, tropical shrimp trawling accounts for about 27% (1.9 million tonnes) of all global discards with an average discard rate of 62.3% (Kelleher 2005). Shrimp trawling is generally regarded as one of the least selective fishing methods not only because of the quantity of discard but also the wide diversity of species caught. In addition, several nationally and internationally protected species occur in global shrimp trawl bycatch including sea turtles, sharks, dugongs, sea snakes, sea horses, coral and some fish species (Eayrs 2007).

Observer data will be used to determine the status of shrimp stocks by complementing survey data, assess the impact of juvenile fish catch on the finfish stocks and determine the extent of sea turtle bycatch in Eastern Atlantic waters.

7.3 List of Priorities

1. Collect information on fishing effort
2. Randomly sample catch for catch composition
3. Record gear characteristics
4. Collect length-frequency data on target and non-target catch

7.4 Gear description

Industrial shrimp trawl vessels employ a variety of otter trawl configurations (Vendeville 1990; Figure 7-1). Some vessels tow one or two nets from the stern (Figure 7-1A-B) whereas most shrimp vessels in West Africa tow either two or four nets simultaneously at the extremities of two outriggers (Figure 7-1C-D). Occasionally, these vessels may tow a smaller, separate net (or try net) which is towed to test for shrimp concentrations or to determine other fishing conditions. You may also observe pair trawl operations (two vessels towing one net; Figure 7-2).

Net configurations are also variable but in general a warp (cable) is connected to a bridle attached to two doors (or otter boards). The net is connected to the doors by two lines – the bottom and top leg lines (Figure 7-3). The net has three main sections: wings, body and codend. The codend lies at end of the net and is where the catch accumulates. Some nets have a fourth extension section that extends the overall length of the trawl.

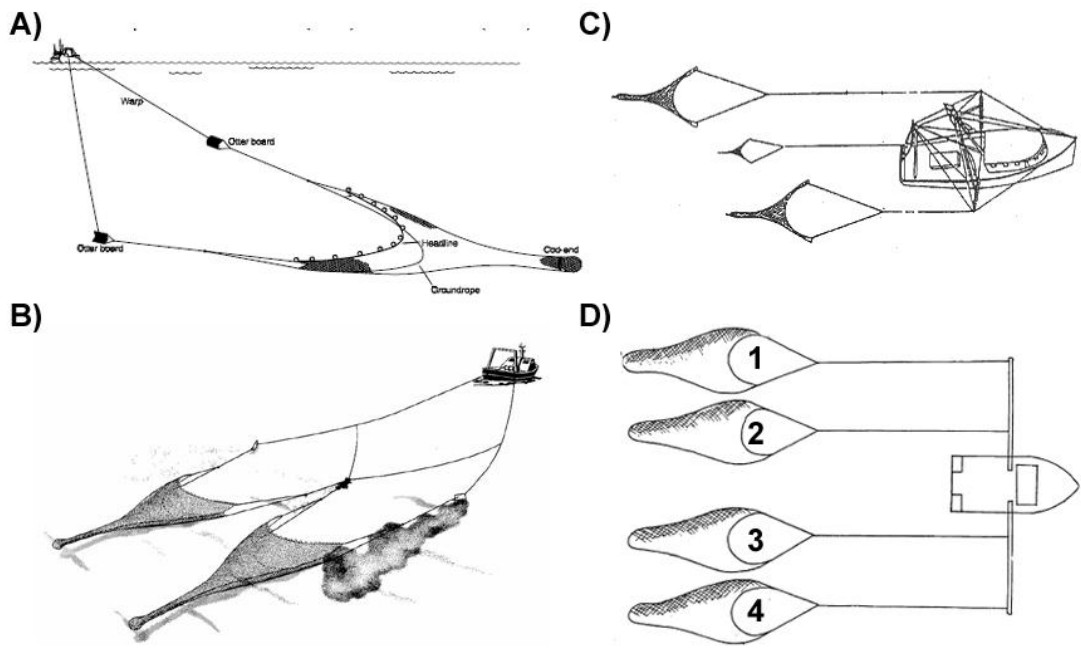

Figure 7-1 Shrimp trawler net configurations: A) stern trawler with single net, B) stern trawler with twin trawl, C) outrigger trawler with two single nets and a try net, D) outrigger trawler with twin trawl. Images modified from FAO (2001b), Lokkeborg (2005) and <http://www.crimond.com>.

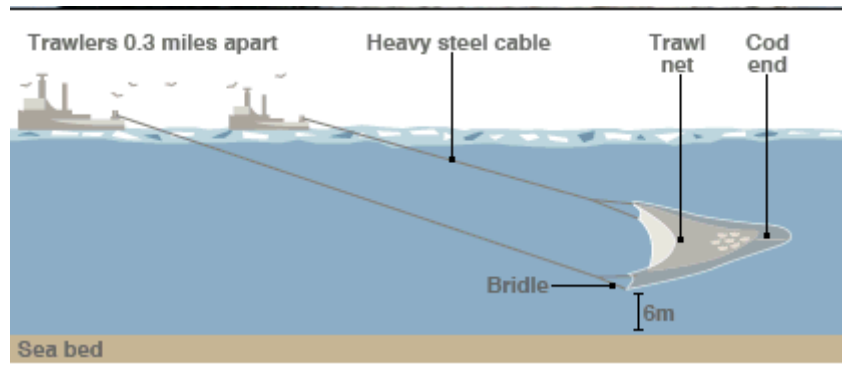

Figure 7-2 Pair trawl – one net pulled by two vessels. Image from http://news.bbc.co.uk/2/low/uk_news/7097257.stm.

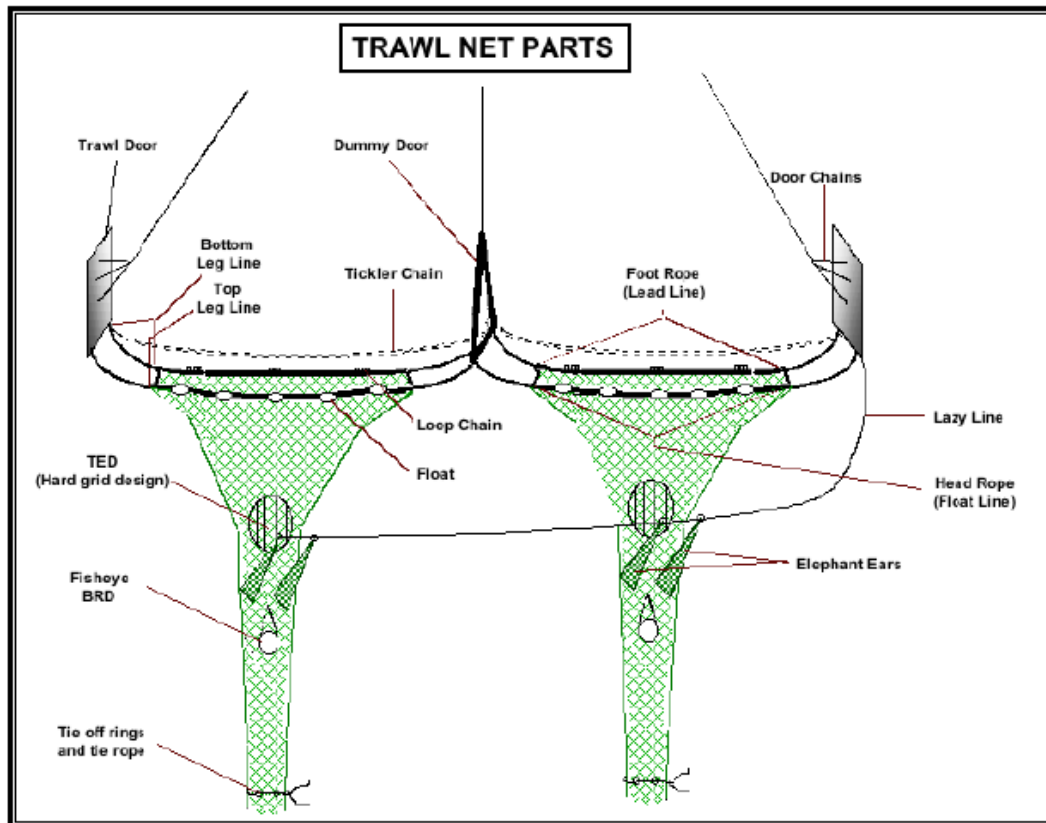

Figure 7-3 Generalized shrimp net diagram modified from NMFS (2008b). For locations of wing, body, extension, and codend see Figure 6-3.

Bycatch reduction devices (BRDs) include a variety of gear modifications for reducing the catch of unwanted juvenile fish or other species. BRDs may also be called a trash fish or junk fish excluder (JTED). **Trawl or turtle excluder devices (TEDs)** are specialized BRDs designed to minimize turtle and other large species catch. BRDs are categorized by how they function. They either separate the catch by size or exploit behavioural differences of certain species to exclude them from the catch. Figure 7-4 and Figure 7-5 illustrate a few types of BRDs and TEDs, respectively. Some countries (namely the U.S.) have TED requirements for shrimp catch destined for import.

Shrimp are typically packaged in units of number per kilogram (or pound). They can be packaged the head on or off, peeled or unpeeled, cooked or uncooked or any combination these. If shrimp are frozen at sea, you may hear the term glazing (a protective coating of ice on a frozen product that prevents dehydration). Sometimes the glazing contains preservatives. For market, shrimp are also classified by color including white, brown, pink, red, tiger (striped) and other categories.

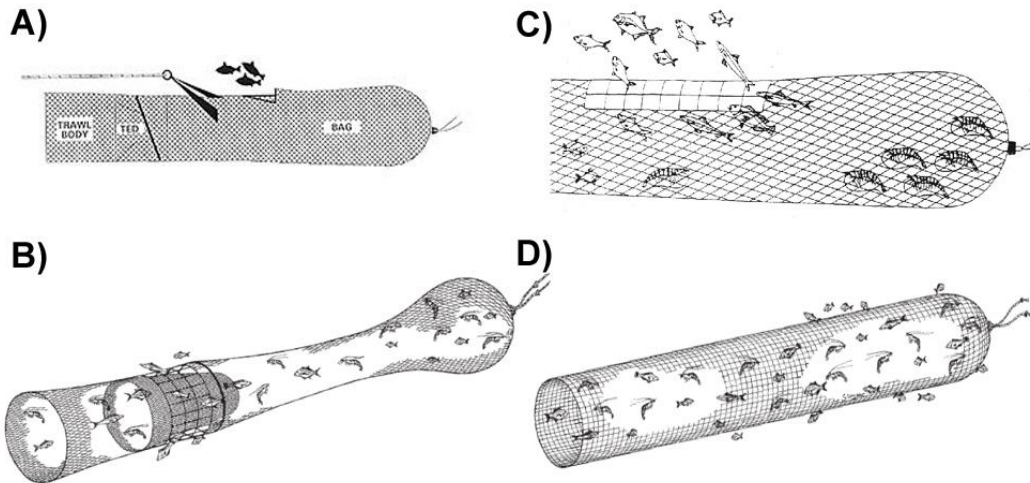

Figure 7-4 Examples of BRDs: A) Fish eye, B) Radial escape section, C) Square mesh window and D) Square mesh codend. Drawings modified from Crespi and Prado (2002-2009) and Eayrs (2007).

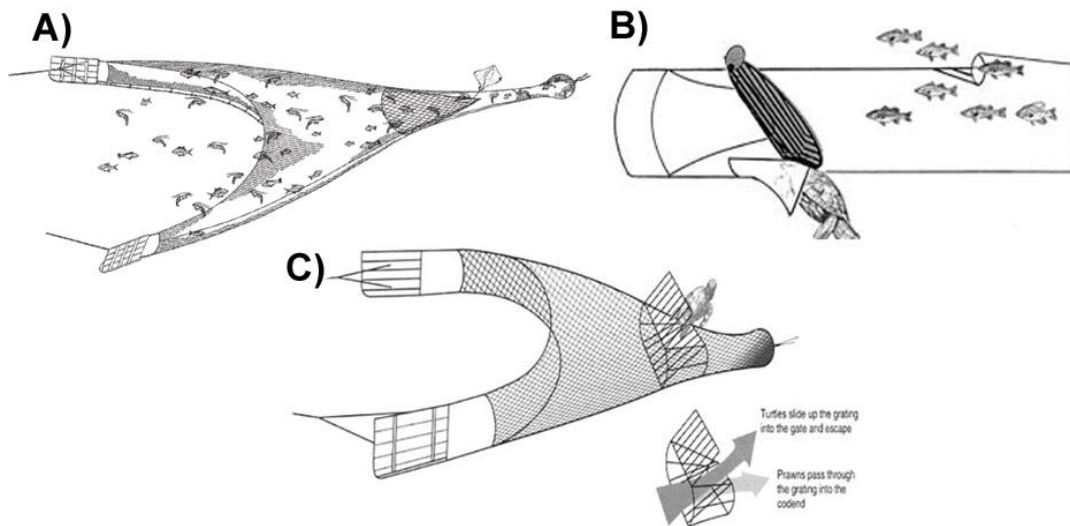

Figure 7-5 Examples of TEDs: A) Soft TED, top release, B) Hard TED, bottom release and C) Hard TED, top release. Drawings modified from <http://www.arbec.com.my/sea-turtles/art34julysept01.htm>, <http://www.seagrantfish.lsu.edu/management/TEDs&BRDs/index.htm> and Eayrs (2007).

7.5 Forms/Instructions

7.5.1 Gear Description – Shrimp Trawl

Complete one form for each unique net configuration (including try net). If possible, complete before departure. Total number of pages equals total number of different nets. Example shown in Figure 7-7.

Field	Definition
Observer Code:	Record your observer program identification code.
Vessel Code:	Record the vessel code (Appendix 3). If your vessel is not on this list, contact the SOP immediately.

Trip ID	Enter the trip identification number assigned by the program.
Total # nets	Record the total number of nets fished (including try net).
Vessel configuration	Check whether vessel is rigged with outriggers. Leave blank if outriggers are absent.
Net # / position	Check the appropriate box (boxes) for the net's position (1 to 4 as illustrated in Figure 7-1D) or "try" for try net specifications. If any or all of the nets are identical, check multiple positions. Net position 1 denotes the outside port net and number 4 denotes the outside starboard net on a quad-rigged vessel (i.e., 4 nets). On a two-net vessel, the port net is number 2 and starboard is number 3. Note the location of the try net relative to main nets (e.g., in front of net #3 or off stern between nets 2 & 3).
Net manufacturer / design name	Ask the captain for the name of the net manufacturer and model or design name if available. If net is made on board, record none.

Doors – Main & Dummy – The main doors are also referred to otter boards. The dummy door, or sledge, is used as a center door during twin trawl operations. If vessel fishing only 1 net or individual nets on each side, leave dummy door section blank.

Material	Circle the construction material for both door types.
Length & height	Record the length and height of both door types in meters.

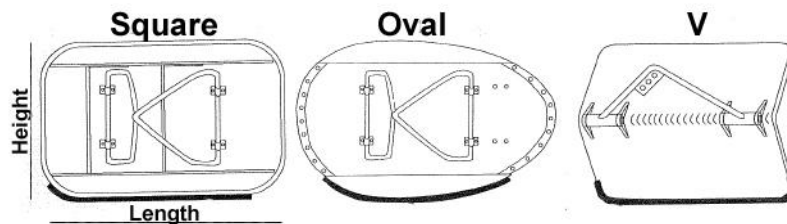

Drawing modified from Hanrahan et al. (1997)

Weight	Record the door weight in kilograms (from Captain).
Type	Circle square, oval, V or other.

For each of the following components, record the length (meters), diameter (millimeters), material (e.g., steel for leg lines and poly, Spectra, or nylon for head/foot ropes) and other information as necessary. For the various types of chain, record overall length (meters), diameter (mm; diagram below) and material.



Chain link diameter (Image from <http://www.mcmaster.com>).

Warp	Warp (or main cable) connects the vessel to the trawl doors.
Bridle (door chain)	The bridle connects the doors to the warps (main cables to vessel).
Top leg line	On the main door, the top leg line length is measured from the point of cable attachment at the door to the attachment point on the top of the net.
Bottom leg line	On the main door, the bottom leg line length is measured from the point of cable attachment at the door to the attachment point on the bottom of the net.
Top & bottom leg line - dummy	Complete for vessels towing a twin trawl (e.g. two main doors plus a middle dummy door; Figure 7-1B).
Head rope	Also known as float line, float rope. Record number of floats or kites attached to head rope and describe in 'Other' column.
Foot rope	Also known as lead line.
Tickler chain & loop chains	The tickler chain is a continuous piece of chain attached in front of the foot rope whereas loop chains are smaller sections of chain attached to the footrope. Their function is to dislodge shrimp from the bottom and into the net. Record a total weight for the tickler chain and a weight and count of the loop chains.

Net Characteristics Section

Most of the net specification will need to be obtained from the captain. Specifications indicated with an asterisk (*) should be measured by the observer.

Total length Record the total net length in meters. You will likely need to ask the captain.

Mouth width Record the mouth width in meters.

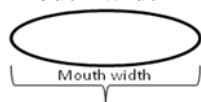

Mouth height Record the mouth height in meters.



Record the material type (e.g., nylon, poly, sapphire, or spectra), line or twine diameter (mm), mesh opening (cm; stretched mesh opening measured from inner knot to inner knot; Figure 6-6), indicate if mesh opening measurement was made when the gear was wet (W) or dry (D), count the number of meshes on the long or horizontal axis and the number of meshes around the net (vertical axis).

Wing	Sections of netting at the foremost part of the net which define the outer perimeter of the trawl opening. The wings maintain the shape of the trawl and herd fish into the net opening.
Trawl body	May be referred to as square and belly. If this section tapers, record the range of mesh sizes.
Extension	The extension, or lengthening piece, is a section between the body and the codend and is used to extend the overall length of the trawl. If extension isn't present, leave fields blank.
Codend	<p>The codend, or bag, is the section that collects the fish. Circle the diamond or square for how the codend mesh is hung relative to the selvedge line.</p> <p>*Codend mesh opening should be measured independently using the wedge gauge issued. Push wedge into stretched mesh opening and apply consistent force (~5kg). Measure 10 meshes and record in the comments field. Calculate the average mesh opening size and record on the form.</p>
Other	Record any other types of mesh sections not already recorded (e.g., codend liners).
Other rigging present.	<p>Check each additional rigging component that is present on the net.</p> <p>Elephant ears are sewn to the end of the net in order to evenly distribute the lifted weight.</p> <p>Lazy line used to lift and maneuver the net and is attached to the elephant ears.</p> <p>Chaffing gear can be pieces of line or extra webbing attached to the codend to protect it from damage.</p> <p>Add any other gear and make detailed comments in the comments field at the end of the form.</p>
Comments	Record any additional comments or make drawings about the gear here.

Bycatch Reduction Device (BRD)

If there is no BRD, leave this section blank.

Type	Check BRD type. Fisheye, Radial escape section, Square-mesh window, Square-mesh codend, or other (specify in space provided).
------	---

Funnel Check Yes or No for the presence of a herding funnel/cone.

Distance from escape opening to headrope Measure in meters.

Distance from escape opening to tie off rings Measure in meters.

Fisheye

Offset Number of meshes offset from top center. If located at top, enter "0"

Opening height & width Measure in cm

Shape Check appropriate opening shape: oval, diamond, square, halfmoon, rectangle, triangle, or specify if other.

Radial escape section

Opening width, height, length Measure applicable dimensions in cm

openings If the radial escape section isn't continuous around the codend, record the number of openings.

Square mesh window

Opening width, height, length Measure applicable dimensions in cm

BRD notes/drawing Provide additional notes and draw a diagram.

Turtle Excluder Device (TED)

If there is no TED, leave this section blank.

Name Record the common name of the TED design (e.g., Nordmore grid, Morrison). Ask captain. If unknown, leave blank.

Type Circle whether the TED is Hard or Soft. Hard TEDs are typically rigid and made of aluminum, steel or plastic. Soft TEDs use a non-rigid incline of mesh (Eayrs 2007).

Opening Circle location for opening: Top or Bottom

Funnel The guiding panel or funnel is located forward of the TED and is used to accelerate the catch through the TED and toward the

codend. Circle Yes if present and No if absent

Flap The escape cover or flap is an extension of mesh behind farthest part of TED opening. Circle Yes if present and No if absent

Material Enter the material type used in TED construction (e.g., aluminum for hard TED or polypropylene mesh for a soft TED).

Shape Circle whether grid shape is rectangular, oval or other (describe).

Angle Use a protractor (angle finder) to obtain the angle (θ in Figure 7-6) of the TED (with respect to the plane of the net) while the nets are hanging freely. Typical angles range between 45-60°.

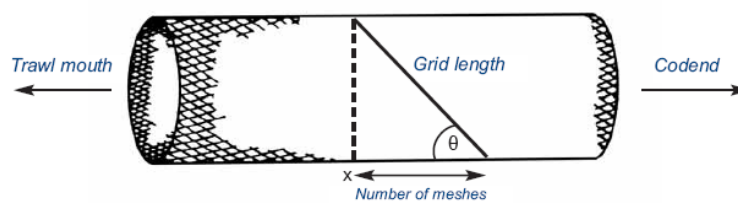

Figure 7-6 Grid angle diagram (Eayrs 2007).

Design Circle whether bars are curved, straight or other (describe).

Dimensions Enter the total length and width of the TED grid as well as bar spacing in centimeters.

Distance from headrope Record the distance of TED from the headrope in meters.

Floatation Record number of floats attached to TED and circle the material type and shape.

TED notes/drawing Provide additional notes and draw a diagram.

Photos? Circle Y, if photos were taken. Remember to record in Observer Logbook (Photo Log) and to provide copies to your debriefer.

Gear Description - Shrimp Trawl

Observer code 175		Vessel code XYZ 3856		Trip ID 00275		
Total # nets: 4		Vessel configuration: <input checked="" type="checkbox"/> Outrigger				
Net # / position (check one or more if nets are identical)						
<input checked="" type="checkbox"/>	1	Port - outside	<input checked="" type="checkbox"/>	3	Stbd - inside	
<input checked="" type="checkbox"/>	2	Port - inside	<input checked="" type="checkbox"/>	4	Stbd - outside	
					5 Try net Location:	
Net Manufacturer / design name: <i>Africa Net Systems / Jumbo Shrimp Special</i>						
Doors - Main			Doors - Dummy			
Material:	Aluminum / Steel / Wood Other:		Material:	Aluminum / Steel / Wood Other:		
Length (m)	1.35	Width (m)	1	Length (m)	1.2	
Weight (kg)	300	Type	Square / Oval / Other	Weight (kg)	200	
				Type	Square / Oval / Other	
	Length (m)	Diameter (mm)	Material	Other		
Bridle (door chain)						
Top leg line	1.5	5	Spectra			
Bottom leg line	1.5	5	Spectra			
Top leg line-dummy	1.5	5	Spectra			
Bottom leg line - dummy	1.5	5	Spectra			
Warp	150	7	Stainless			
Head rope	4	8	Nylon	# floats: 5		
Foot rope	4	8	Nylon			
Tickler chain	4.1	3.5	Chain	Weight: 50		
Loop chain						
Net Characteristics						
Total length (m):		Mouth width:			Mouth height:	
	Material	Diameter (mm)	Mesh open (cm)	W / D	# meshes horiz	# meshes vert
Wing	<i>Poly</i>	4	10	<i>W</i>	60	30
Trawl body	<i>Poly</i>	3	5	<i>W</i>	80	40
Extension	<i>Poly</i>	3	5	<i>W</i>	80	40
Codend	<i>Poly</i>	2	3.5	<i>W</i>	120	70
Other						
Other						
Other rigging present? Check all that apply.						
<input type="checkbox"/>	Elephant ears	<input type="checkbox"/>	Choke rings	<input checked="" type="checkbox"/>	Lazy line	Other:
<input checked="" type="checkbox"/>	Chafing gear					Other:
Comments:						

Bycatch Reduction Device (BRD)			
Type: <input type="checkbox"/> Fisheye		<input type="checkbox"/> Square-mesh window <input type="checkbox"/> Other:	
<input type="checkbox"/> Radial escape section		<input type="checkbox"/> Square-mesh codend	
Funnel	<input type="checkbox"/> Yes	Distance of escape opening from headrope:	<input type="text"/> m
	<input type="checkbox"/> No	Distance of escape opening from tie off rings:	<input type="text"/> m
Fisheye		Radial escape section	
Opening (cm)	Width <input type="text"/>	Height <input type="text"/>	Offset <input type="text"/>
Shape		Opening (cm)	Width <input type="text"/>
<input type="checkbox"/> Oval	<input type="checkbox"/> Diamond	Height	<input type="text"/>
<input type="checkbox"/> Square	<input type="checkbox"/> Halfmoon	Length	<input type="text"/>
<input type="checkbox"/> Rectangle	<input type="checkbox"/> Triangle	If not all the way around, #openings <input type="text"/>	
<input type="checkbox"/> Other:		Square-mesh window	
		Opening (cm)	Width <input type="text"/>
		Height	<input type="text"/>
BRD notes/drawing			
Turtle Excluder Device (TED)			
Name:		Type: <input checked="" type="radio"/> Hard <input type="radio"/> Soft	
Opening: Top / <input checked="" type="radio"/> Bottom	Funnel <input checked="" type="radio"/> Yes / No	Flap <input checked="" type="radio"/> Yes / No	
Material: <i>Hard PVC Pipe</i>		Shape: Rectangle / <input checked="" type="radio"/> Oval / Other:	
Angle (°): <i>Not sure</i>	Design: Curved bar / Straight bar / Other: <i>Mostly straight w/curve at bottom</i>		
Dimensions		Distance of TED from headrope: <input type="text"/> 1.5 m	
Length: <input type="text"/> 150 cm	# TED Floats: <input type="text"/> 5		
Width: <input type="text"/> 125 cm	Float material: Sponge / Foam / <input checked="" type="radio"/> Plastic / Other:		
Bar Spacing: <input type="text"/> 8 cm	Float shape: Round / Cylinder / Bullet / <input checked="" type="radio"/> Ellipsoid		
TED notes/drawing			
			
Photos? <input checked="" type="radio"/> Y <input type="radio"/> N			
Version 1.0 6/2010			

Figure 7-7 Example Gear Description form for Shrimp Trawl.

7.5.2 Trawl Effort / Total Catch Form

This form is the same for finfish and shrimp trawl. Refer to Section 6.5.2 (page 6-14) for detailed instructions.

7.6 Catch Composition Sampling

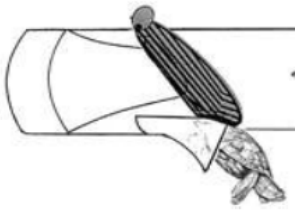
Depending on the number of hauls made per day, it may be physically impossible to sample all hauls. Therefore, random sample tables (RST) have been developed so that hauls are selected at random. There are two RSTs set up for different situations (Table 6-1). RST#1 is set up to sample 2 or 3 hauls in a row followed by one 'off' or unsampled haul. The haul sampling rate for RST#1 is ~70-72%. RST#2 is set up to sample 2 to 4 hauls in a row with one or two 'off' or unsampled hauls between. The haul sampling rate for RST#2 is ~65-70%.

Once a haul is selected for sampling, follow steps in Section 6.7 and Figure 6-18. Catch composition is recorded on the generic Catch Composition form described in Chapter 5.

7.7 Biological Data

If assigned length collection, follow protocol provided at that time.

8 Pelagic Longline

8.1 Learning objectives

- Describe 4 components of pelagic longline gear
- List the 3 forms that must be completed that are specific to pelagic longline vessels
- List 3 pieces of information that must be collected from each organism
- List 2 scenarios for reducing sampling duties and explain how sampling may be modified

8.2 Introduction

Longline gear is one form of hook and line gear that uses baited hooks to attract and catch fish. Pelagic longlines are also known as drifting longlines because the gear typically drifts with the ocean currents while fishing (Figure 8-1). Pelagic longlines target fish at or near the surface such as tuna, swordfish and some shark species. Although hook and line gear of all types only accounts for approximately 10% of global fisheries catch (Watson et al. 2006), nearly 16% of global tuna catch is harvested with pelagic longline gear (FAO 2009a).

In general, longlining is considered to be selective in the size of fish captured (e.g., large hooks catch large fish). Many fish remain alive and can be returned to sea with a high survival rate. However, pelagic longlining, especially while targeting swordfish, has had a significant impact on sea turtle populations. There are also concerns regarding sharks and seabirds in some fisheries (FAO 1999).

8.3 List of Priorities

1. Estimate effort for each gear deployment;
2. Identify every individual caught on each set and assess catch condition and fate;
3. Collect biological information on target and other identified species as requested;
4. Record all sightings and interactions with marine mammals and sea turtles;
5. Record vessel and fishing gear characteristics.

8.4 Gear Description

A pelagic longline consists of a mainline held near the surface or at a certain depth by means of regularly spaced floats and has evenly spaced baited hooks attached by branchlines (also known as snoods or gangions; Figure 8-1). Pelagic longlines may be of considerable length (20-120 km). Some pelagic longlines are set vertically, each line hanging from a float at the surface.

The main components of a pelagic longline are the mainline, branchlines, hooks, floats and gear markers (Figure 8-1). Mainline materials are typically a thick monofilament line and may be stored on a drum or, if in smaller sections, in a large bin. Pelagic longline gear is deployed in sections called baskets (or skates/magazines) which have 6 to 40 branchlines attached between floats (buoys). Branchlines can be more than 30m in length and are attached to the mainline with a snap (or clip; Figure 8-2). Branchlines can be simple with one

type of line material between the snap and the hook or they can be more complex with multiple types of line and swivels attached. Hooks are attached to the lower end of the branchline and also come in a variety of shapes and sizes although the most common are the tuna, circle and J-hook styles (Figure 8-3). The baiting of hooks may be manual or by a machine (baiting machine). Line shooting and bait casting machines are also often used. Vessels are equipped with a hydraulic line hauler for gear retrieval and a sometimes a branchline coiler to wind and store the branchlines.

Gear markers are used to mark the location of the fishing gear and may include buoys (floats), radar reflectors (highflyers), radio beacons, GPS beacons and lights (Figure 8-4). Floats (buoys) are also deployed between baskets.

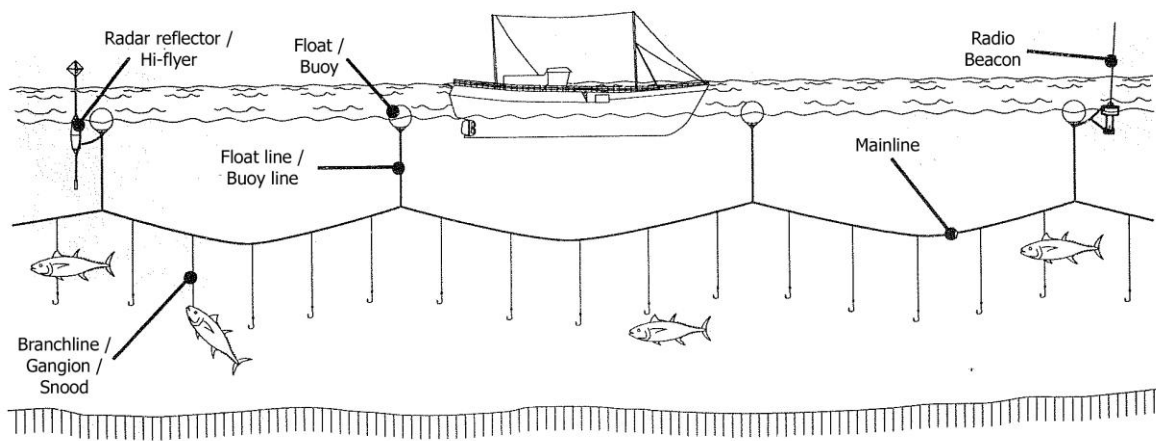

Figure 8-1 Pelagic longline gear components. Modified from Hanrahan et al. (1997).

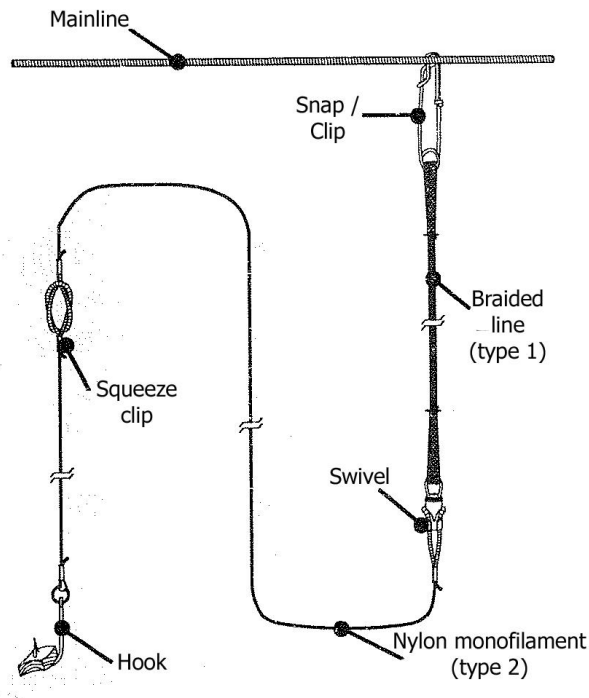

Figure 8-2 Branchline configuration. The braided line and monofilament are two examples of material branchlines can be made of. Modified from Hanrahan et al. (1997).

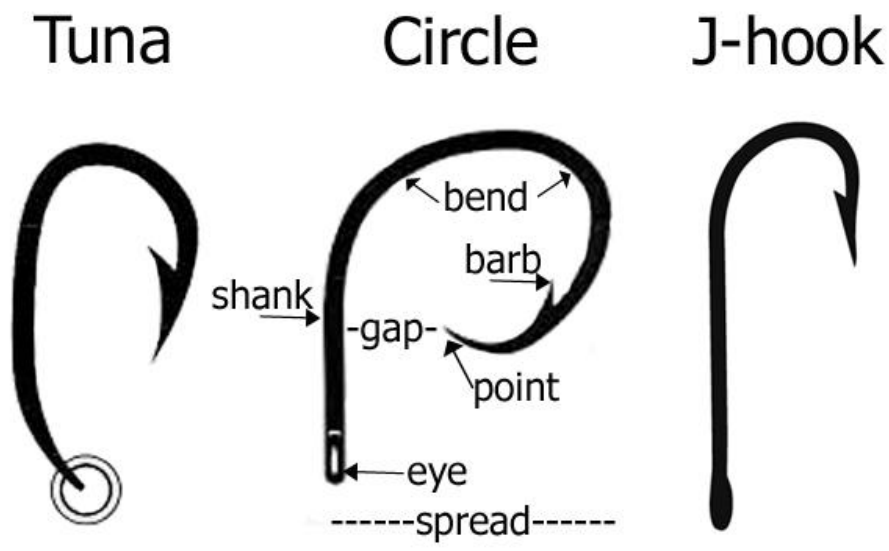

Figure 8-3 Hook types and terminology. The J-hook shank is parallel to the point and is shaped like the letter “J”. Circle hooks have a point that bends in at approximately 90° and the tuna hook has a bent shank. Modified from Beverly (2006, 2009).

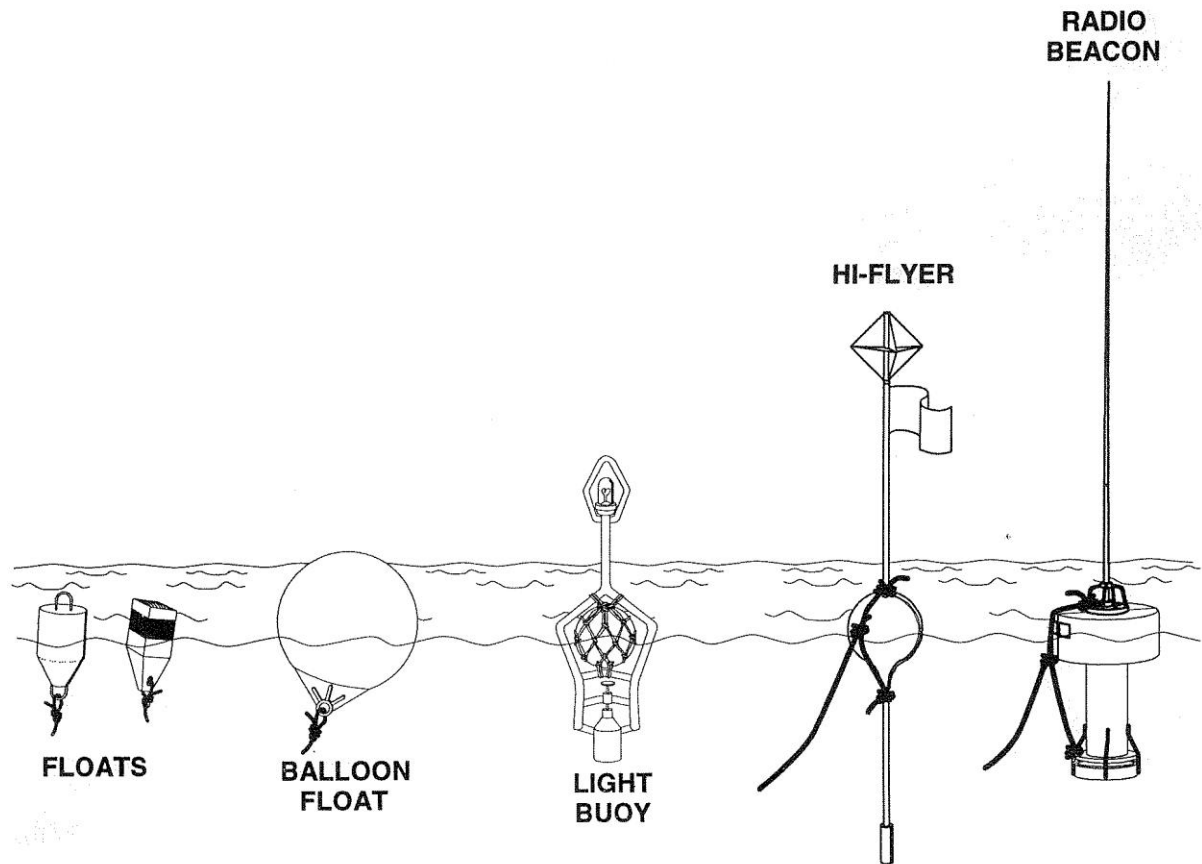

Figure 8-4 Types of floats and buoys. Modified from Hanrahan et al. (1997).

8.5 Fishing Description

Gear deployment: The longline is typically deployed from the stern of the vessel. This may also be called setting or shooting. An end buoy with a gear marker is deployed first and baited branchlines (snoods) and floats are attached at desired intervals as the main line is payed out. A synchronous series of beeps may indicate when crew should attach the next branchline. The vessel travels at 6-12 knots while gear is being deployed. The length of the mainline, ideal fishing depth and number of hooks per basket varies with the intended target. Fishing depth is a function of floatline length, branchline length, currents, tides and amount of sag in the mainline (or distance between floats/buoys; Bigelow et al. 2006).

Gear retrieval: Longlines are left in the water from several hours to a day. Gear retrieval begins by locating the gear marker at one end of the mainline, then hauling it and the buoyline onboard. The main line is fed into a line hauler and the gear is pulled in. Hooked fish are brought on board using long gaff hooks. The mainline can be coiled and stored in containers or may be wound directly onto a drum. Snaps are removed individually and branchlines are wound up for storage either by hand or with a branchline coiler. The rate at which hooks come on board depends on weather, fishing depth, and hook spacing; however, in general, a hook should come up every 3-6 minutes.

8.6 Forms/Instructions

8.6.1 Gear Description Form – Pelagic Longline

Complete once per trip (see Figure 8-6 for an example). Most gear information can be obtained from the captain or deck boss.

Field	Definition
Observer Code:	Record your observer identification code.
Vessel Code:	Record the vessel code (Appendix 3). If your vessel is not on this list, contact the SOP immediately.
Trip ID	Enter the trip identification number assigned by the SOP.
Lines	For each type of line found on board (including each component of a branchline), record the material code, diameter (millimeters), breaking strength (or test; kg), number of strands and color code. It is normal for there to be only one mainline type. If this is the case, then complete the row for “Mainline Type 1” only. Branchlines are frequently constructed with two or three types of material.

If there are more than two types of mainline or floatline or if branchlines consist of more than 4 material types, use additional rows and number types accordingly.

Material codes include:

- 1 – Monofilament
- 2 – Multifilament
- 3 – Cotton
- 4 – Steel wire
- 5 – Other (please specify, e.g. tarred red polyester)

Color codes

- | | | |
|-----------|------------|------------------|
| 1 – White | 5 – Blue | 9 – Yellow |
| 2 – Pink | 6 – Red | 10 – Other |
| 3 – Black | 7 – Clear | 11 – Multi-color |
| 4 – Green | 8 – Orange | |

Record any additional information about each line in the comments box.

Hooks	For each type of hook used by the vessel, record the manufacturer, model/pattern, size, material, and degrees of offset. The common model/patterns include the tuna hook, J-hook and circle hook (Figure 8-3). If the shank is flat, make a note of this in the comment section.
-------	--

Hook sizes are not standardized. They may be in a metric unit or another convention that uses a slash (e.g., 9/0). Record what is on the

box. If no information is available from the manufacturer, try to bring a sample back or take a photo including a side and front view with a ruler for scale.

Hooks are typically stainless steel (shiny) or galvanized (dull) but verify the material with the captain (Beverly 2009).

Offset is measured in degrees. A hook is offset if the point does not line up exactly with the shank when the point-side is facing you (Figure 8-5). Offset hooks do not lay flat.



Figure 8-5 Offset (left) and non-offset hooks. Image from Beverly (2009).

Gear Deployment Location Check appropriate box for whether longline gear was deployed from the stern, starboard or port of the vessel. If from the side, also record how far from the stern (in meters).

Check appropriate box for whether the gear was deployed into the propeller up- or down-wash.

Other equipment For each device, circle **Yes** or **No** for whether the device was present on board and record a usage code defined as:

- | | |
|---|----------------------------|
| 1 Used continuously during fishing | 5 Rarely used |
| 2 Used often during fishing | 6 Used only during transit |
| 3 Used sometimes during fishing | 7 No longer used |
| 4 Broken during this trip but used normally | 8 Unknown |

Mainline hauler – uses hydraulic motor to assist with pulling gear on board.



Branchline hauler/coiler – winds branchlines into tight, consistent coils



Line setter / shooter – used to pull mainline from drum or deploy mainline at a consistent speed during setting

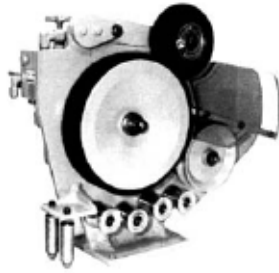

Bait caster (catapult / thrower) – used to place bait away from the vessel outside of wake zone or within protection of streamers.

Seabird Mitigation: Describe all techniques and equipment used to deter birds from hooks during the set and haul (e.g. bird curtain). Include diagrams with measurements of streamer lines and other equipment as necessary.

Gear Description - Pelagic Longline

Observer code <i>SLE 0001</i>	Vessel code <i>12345</i>	Trip ID <i>1</i>
----------------------------------	-----------------------------	---------------------

Lines	Diameter		Breaking		Color	Comments
	Type	Material	(mm)	strength (kg)		
Mainline	1	1	4	600	1	5
Mainline	2					
Floatline	1	5	5.5	400	3	9 <i>Material=Polypropylene</i>
Floatline	2					
Branchline	1	3	2	800	3	4
Branchline	2	1	2	800	1	7
Branchline	3	4	1.8	265	7x7	10 <i>Color=metal (coated stinless steel)</i>
Branchline	4					

Material Codes		Color codes			
1 Monofilament	4 Steel wire	1 White	4 Green	7 Clear	10 Other
2 Multifilament	5 Other: _____	2 Pink	5 Blue	8 Orange	11 Multi-color
3 Cotton		3 Black	6 Red	9 Yellow	

Hooks	Type	Manufacturer	Model/pattern	Size	Material	Offset
	1	<i>Mustad</i>	<i>tuna</i>	3.8	<i>stainless</i>	0
	2	<i>Eagle claw</i>	<i>circle</i>	16/0	<i>high carbon steel</i>	10°
	3					
	4					

Model/pattern types



Tuna

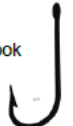

J-hook



Circle

Other (describe):

Gear Deployment Location

<input type="checkbox"/> Stern	<input type="checkbox"/> Propeller up-wash
<input checked="" type="checkbox"/> Stbd, distance from stern <u>5</u> m	<input checked="" type="checkbox"/> Propeller down-wash
<input type="checkbox"/> Port, distance from stern _____ m	

Other Equipment			Usage
Mainline hauler	Y / N		1
Branchline hauler / coiler	Y / N		1
Line shooter	Y / N		1
Bait caster	Y / N		4
Weighing scales	Y / N		
Other:	Y / N		
Other:	Y / N		
Other:	Y / N		
Other:	Y / N		
Other:	Y / N		

Usage Codes

- 1 Used continuously during fishing
- 2 Used often during fishing
- 3 Used sometimes during fishing
- 4 Broken during this trip but used normally
- 5 Rarely used
- 6 Used only during transit
- 7 No longer used
- 8 Unknown

Seabird Mitigation

Describe all techniques and equipment to deter birds from hooks during the set (e.g. streamer lines) and haul (e.g. bird curtain). Include diagrams with measurements of streamer lines and other equipment as necessary.

Set *One streamer line deployed from stbd side; mainline made of 6mm ploy line; packing straps were white or yellow*

Haul *Used a water pump to create a "water curtain" on port, aft quarter of vessel to deter birds from hooks during haul*

Comments

Figure 8-6 Example Gear Description for Pelagic Longline.

8.6.2 Set and Haul Information Form

The Set and Haul form is used to record the basic fishing effort parameters of all longline sets during observed trips (Figure 8-8 contains an example). The information necessary to complete this form is obtained through direct observations. If an element is not available or applicable, leave the field(s) blank and describe the situation in the Comment section. Fields indicated with an asterisk (*) relate to fields on Gear Description form.

- Field** **Definition**
- Observer Code: Record your observer identification code.
- Vessel Code: Record the vessel code (Appendix 3).
- Trip ID Enter the trip identification number assigned by the program.

Set No. Record the set number (unique and consecutive for each trip).

Target Ask the captain for the intended target species for each set. Record using 3-digit FAO code (0). This will likely remain constant for a trip.

Page ___ of ___ Number pages consecutively throughout the trip.

Several fields must be collected at the beginning and ending of each set and haul period. It may take more than four hours to set (deploy gear) and over 12 hours to haul (retrieve) a set. For each set, you will record four dates, times, positions, SSTs and sea states.

Date There is a separate column for day, month and year. Record 2-digits in each column.

Time (24-hr) Record time for each component using 24-hr notation (e.g., 8:45 a.m. = 0845 and 2:12 p.m. = 1412). Start and end setting times are defined when the first and last hooks go in the water, respectively. Start and end hauling times are when the first and last hooks come back on board, respectively.

Lat-Deg Record degrees of latitude (2-digits) for start and end of the set and haul periods.

Lat-Min Record the minutes of latitude (to hundredths of a minute; 4-digits)

Lat-N/S Record **N** for all latitudes North of the equator and **S** for latitudes south of the equator.

Long-Deg Record degrees of longitude (3-digits).

Long-Min Record the minutes of longitude (to hundredths of a minute; 4-digits)

Long-E/W Record **W** for all longitude West of the prime meridian (e.g., 0°) and **E** for longitudes east of the prime meridian.

SST Record the sea surface temperature as a 3-digit number to the nearest 0.1 degree Celsius. Use the vessel's thermistor (thermometer probe). If the vessel does not have a working thermistor and you were issued a thermometer, use the issued thermometer to collect a temperature reading using the following steps:

1. Cast the water-collecting container overboard into water which is least affected by external heating from the vessel

(i.e., away from engine cooling water discharges). Avoid sampling near overboard discharges. This is dangerous if the vessel is moving so make sure vessel has stopped before putting anything overboard yourself.

2. Collect enough water to fill the well and insert the thermometer.
3. Allow roughly 15 seconds for the thermometer to equilibrate before recording the temperature.

If neither you nor the vessel has an operable thermometer, leave this column blank and make a note in the comments section.

Sea state	Record the dominant sea state using definitions in Appendix 12.
V / O	Record O if the observer independently recorded time, position and environmental conditions. Record V if the information was obtained from a vessel's fishing log or the captain.
Set Speed	Obtain the average setting speed (tenths of knots) from captain.
Max depth	Ask the captain how deep he wants the deepest part of the gear to fish. Record maximum depth in meters. If you need to convert units, record conversion calculation in comments section.
Seabird mitigation	Check box if any seabird mitigation device was used during the set or haul. Make notes in the comments section regarding the type of mitigation used.
Haul Dir.	Circle F or R for the haul direction. Forward is defined as the same direction gear was deployed and reverse is the opposite direction as gear was deployed.
Hooks – Type*	Record the dominant hook type deployed for the set. Hook type should relate to the type number on the Gear Description- Pelagic Longline form. If more than one hook type is deployed in a set, record the dominant hook type and make a note in the comments section about the approximate percentage of each hook type. For instance, “80% hook type 1 and 20% hook type 2 were deployed.”
Hooks/basket	Record the mean number of hooks attached per basket (may also be referred to as hooks per float). Count a minimum of 10 baskets during gear deployment and calculate an average.
Total Baskets	Record the total number of baskets deployed. Ask the captain or crew.
Set	Record the total number of hooks set including shark hooks that were attached to the floats. Calculate using the formula:

(Hooks/basket * total baskets) + total shark hooks

Hauled	Record the total number of hooks retrieved. Tally missing hooks as gear is hauled and subtract the number missing from total hooks set.
Tended	Record the number of hooks tended while gear is soaking prior to hauling the gear. This practice may be called ‘hotlining’ and is more common on vessels using live bait.
Rebaited	Record the number of hooks rebaited prior to hauling the gear.
Monitored	Record the number of hooks monitored. Ideally, this will equal the number of hooks hauled. However, sometimes weather or your health may limit your ability to monitor all catch coming on board (see also Section 8.7).
Branchline – Type* and Length	Record the dominant branchline configuration deployed for the set. Record lengths of each component by material type as described on the Gear Description-Pelagic Longline form. The length of the first component starts at the top of the snap. The sum of these lengths should equal the total branchline length (Figure 8-7).

If there are multiple branchline configurations, make a note in the comments section regarding the other configurations and approximate proportion of each configuration deployed.

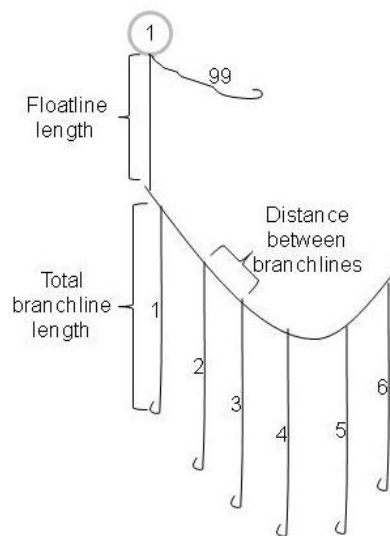

Figure 8-7 Branchline and floatline measurements.

Branchline set	Record the setting interval (in seconds) that the crew is targeting
----------------	---

interval	for branchline attachment. You can also time this yourself.
Distance between	Record the distance between branchlines (in meters) that the crew is targeting for branchline attachment. This can be calculated using vessel setting speed and the branchline attachment interval (above)
Weight (g) and weight placement	Record the total weight of any weight attached to the branchline. This may be incorporated into the swivel(s) or added separately. Make a note where the weights are located (e.g., 30g swivel between material type 2 and 3 and 30g weight attached 20cm above hook).
Floats	Record the total number of floats (including end buoys) deployed.
Float line Type*	Record the dominant floatline type (as described on Gear Description-Pelagic Longline form).
Floatline length	Record the average floatline length (Figure 8-7). Measure several to calculate the average.
Weights	Record the amount of weight (in grams) attached to floatline. If no weights were added, record "0".
Sharkline on floats?	If a sharkline was deployed at the float, record the hook type (from Gear Description-Pelagic Longline form) and total number of sharklines deployed.
Bait – species and kg	Record the approximate weight of each species of bait used for the set. Ask the crew or pay attention to number of boxes of bait used by species.
Bait – Hook No.	If more than one bait species is used, they will typically be put on the same hook numbers within each basket. If this is the case, record the hook position within basket that each bait species was placed. For instance, Squid might go on hooks 4 and 5 while sardines on hooks 1-3 and 6-8 for an 8 hook basket. If this was not the case, leave Hook No. blank.
Mainline length	Ask the skipper for the estimate of the length of mainline deployed. Record in to nearest tenth of a nautical mile.
Gear condition?	Indicate the condition of the gear at the completion of the haul by recording the most appropriate code: <ul style="list-style-type: none"> 0 No problems (<10% hooks lost and/or minor gear damage) 1 Minor problems – 10-25% hooks lost and less than 50% of gear fouled due to weather/oceanic conditions. Gear tangled, spun up effecting gear fishability

- 2 Major problems – >25% of hooks lost and > 50% of gear fouled due to weather/oceanic conditions
- 3 Gear completely damaged or lost
- 4 Gear conflicts (with another fisher)
- 5 Other – explain in comments

Gear parted? Did the mainline part (or break) during gear retrieval? Circle **Yes** or **No**. If yes, make notes in comments regarding parting time and when gear hauling resumed.

Gear lost? Was any gear lost during this set? Circle **Yes** or **No**. If yes, make notes in the comment section.

Light Devices - Type Circle the predominant type of light device attached to gear. If more than one type, make a note in the comments.

Light Devices – How many? Record the total number of light devices attached to the gear.

Light Devices – Placement Record where the majority of the light devices were attached to the gear.

Color code & percent Record the color code and approximate percentage of each color deployed. For example, Code 2 – 50% and Code 8 – 50%. Note that percent recorded must sum to 100%.

Color codes:

- | | | |
|-----------|------------|------------|
| 1 – White | 5 – Blue | 9 – Yellow |
| 2 – Pink | 6 – Red | 10 – Other |
| 3 – Black | 7 – Clear | |
| 4 – Green | 8 - Orange | |

Other devices Check appropriate boxes if temperature-depth recorders (TDRs), hook timers, surface lights or any other devices that may impact fishing effectiveness were deployed. If Other is checked, make notes in comments section.

Comments Use this section to describe any particulars that could not be codified from the available data element choices. If any data elements were left blank, record what was left blank and why the information could not be collected, in this section. If you run out of room, indicate that there are notes elsewhere (e.g., Observer Logbook).

Set and Haul Information - Pelagic Longline

Crew member code	Vessel code	Trip ID	Set No.	Target	Page ___ of ___	
SLE 0001	12345	1	1	BET		

		Date/Time			Position					SST (°C)	Sea state	V/O	Set Speed (kts)	Max. Depth (m)	Seabird Mitigation	Haul Dir.		
		Day	Month	Year	Time (24-hr)	Lat-Deg	Lat-Min	N/S	Long-Deg								Long-Min	E/W
Set	Begin	22	12	09	0655	10	10.52	N	025	17.3	W	27.3	4	0	8.5	90	<input checked="" type="checkbox"/>	
	End	22	12	09	1112	10	20.75	N	024	40.91	W	27.4	4	V				
Haul	Begin	22	12	09	1540	10	12.22	N	025	13.95	W	27.2	5	0			<input checked="" type="checkbox"/>	F
	End	23	12	09	0311	10	21.87	N	025	47.32	W	27.2	6	0				R

Hooks	
Type*	1
Hooks / basket	8
Total baskets	200
Set	1650
Hauled	1609
Tended	0
Rebaited	0
Monitored	1523

Branchline	
Type*	Length
1	10.0
2	10.5
3	1.0
Branchline set interval (s)	
7	
Distance between (m)	
30	
Weight (g)	Weight placement
40	Two 20g swivels at each junction b/w materials

Floats	
#	201
Float line	
Type*	1
Measured length	25.1
Weight (g)	5000
Shark line on floats?	
Hook type*	2
Total set	50

*relate to Types described on Gear Description - Pelagic Longline form

Bait				
Species	SQU			
kg	800			
Hook No.				

Light devices											
Type codes (circle one)	0 None 3 Glow bead 1 Chemical light stick 4 Other 2 Battery light										
How many?	300										
Placement	Junction b/w branchline types 2 & 3										
Color Code	%										
2	75										
4	25										
<table border="1"> <tr> <td>1 - White</td> <td>6 - Red</td> </tr> <tr> <td>2 - Pink</td> <td>7 - Clear</td> </tr> <tr> <td>3 - Black</td> <td>8 - Orange</td> </tr> <tr> <td>4 - Green</td> <td>9 - Yellow</td> </tr> <tr> <td>5 - Blue</td> <td>10 - Other</td> </tr> </table>		1 - White	6 - Red	2 - Pink	7 - Clear	3 - Black	8 - Orange	4 - Green	9 - Yellow	5 - Blue	10 - Other
1 - White	6 - Red										
2 - Pink	7 - Clear										
3 - Black	8 - Orange										
4 - Green	9 - Yellow										
5 - Blue	10 - Other										

Mainline length 35.8 nmi

Gear condition	0	Gear Condition Codes 0 - No problems 1 - Minor problems 2 - Major problems 3 - Gear completely damaged/lost. 4 - Gear conflicts 5 - Other - explain in comments
Gear parted	<input checked="" type="radio"/> N	
Gear lost?	<input checked="" type="radio"/> N	

Other devices? TDRs Hook timers Surface lights Other

Comments
<p>*1636 - line parts but vessel finds the next float (radar deflector attached) and resume hauling by 1700</p> <p>*2300 - line parts again and we end up steaming to other end to haul from that side. Resume hauling by ~0115. By the end of the haul it appears there were ~5 baskets of gear missing (including 1 float w/ a shark hook).</p> <p>*Random break #4 - took 15 minutes to eat at 1620 - missed 37 hooks. If I had known the gear was going to part I would have delayed until we were steaming.</p>

Version 1.0 6/2010

Figure 8-8 Example of completed Set and Haul Information form.

8.6.3 Catch Composition Sampling

Because there are few fish and they come up individually, all fish will be identified, assessed for condition (when caught and released), sexed (if possible) and measured (Figure 8-9).

Observers must monitor the entire haul back, or gear retrieval process.

Field	Definition
Observer Code:	Record your observer identification code.
Vessel Code:	Record the vessel code (Appendix 3).
Trip ID	Enter the trip identification number assigned by the program.
Set No.	Record the set number.
Page ___ of ___	Number pages consecutively throughout the trip.
Blank	First column left blank intentionally.
Hook No.	Record the hook numbers for each animal caught, including those that 'escaped' before being brought on board or were released outboard. For instance, given the diagram below and gear being hauled in the same direction set, the first fish would be recorded as Hook No. 3, the second fish (on the shark hook) as Hook No. 99 and the 3 rd fish as Hook No. 6. All sharklines are indicated with hook number 99. If more than one fish is caught on a hook, record both with the hook number.

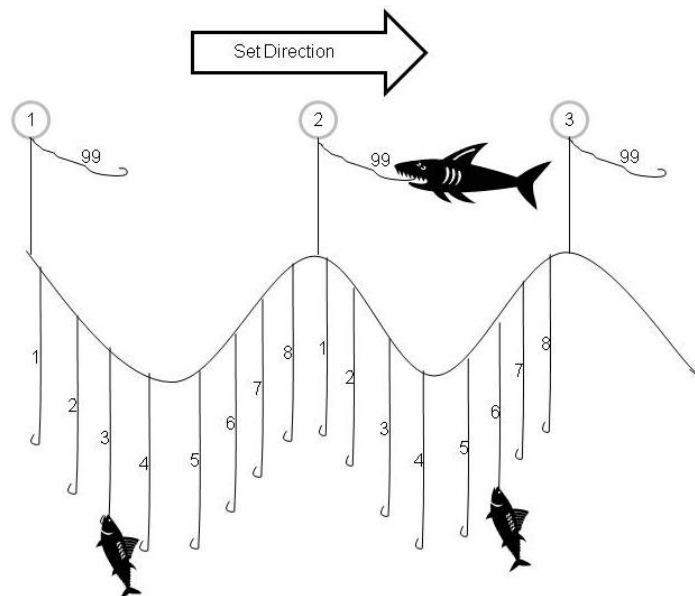

Species name	Record species name to lowest taxonomic level. If animal was not boarded, a higher taxonomic level is acceptable (for example, a
--------------	--

shark breaks the surface & then the branchline parts and you didn't see it well enough to identify it to species, record this as 'Elasmobranch, unidentified, code=SKX'

Species code	Record 3-letter species code (0)
Caught condition code	<p>Record the condition in which the animal was caught using the following codes:</p> <p>A1 Active, not bleeding, no obvious injury A2 Active, bleeding, obvious injury X Inactive / unresponsive / dead U Unknown. Record unknown if you do not see animal as it's brought on board or it escapes prior to boarding.</p> <p>There are some additional codes that apply specifically to marine mammals and sea turtles and link to their respective catch/carcass forms (Chapter 11).</p> <p>A3 Active, unknown condition X2 Previously dead (marine mammals, turtles only) O Other</p>
Kept / return code	<p>Indicate whether the animal was kept or returned using the following codes:</p> <p>K Kept all or part of animal (excluding finned sharks-use code F) A1 Active, not bleeding A2 Active, bleeding, obvious injury X Inactive / unresponsive / dead F Finned U Unknown. Record unknown if you do not observe what happens to the animal.</p>
Damage code	<p>Record any damage an animal has when it comes on board. Only record recent damage. Take photos when possible.</p> <p>Blank No obvious damage</p> <p>NI Did not inspect</p> <p>C Cookie cutter shark – damage appears as a circular or oval-shaped cut out of the body.</p> <p>M Marine mammal – damage will usually result in nearly all of the fish's body being removed often leaving only the fish's head or mouthparts on the hook. The bite will often look jagged with strips of skin and tendons. You may be able to see more widely</p>

spaced tooth marks, or strips of flesh removed, in comparison to shark damage.

S Shark –damage will usually appear as fairly sharp, defined edges of flesh removed as if cut from the body. May see teeth puncture marks, or slashes in the flesh.

U Unknown source of damage. Describe in comments and take a photo.

Sex If it is possible to collect the sex of the fish (possibly when crew is dressing), record the sex using the following codes:

M Male **F** Female

I Indeterminate – use when you inspect the gonads but are unable to decide which sex

U Unknown – gonads were not inspected

For fish that will be returned to sea alive and cannot be sexed using external characteristics, record “U”.

Length types and measurements Record the length type using definitions from Chapter 10. Unless given a special length project, record only one length in the “Length 1” type and measurement columns.

For tuna fisheries you will add a letter code after the numeric length type code defined as follows:

C – Curved –taken in a line tracing the contour of the body

S – Straight –measuring device remains flat (usually under the animal)

E – Estimated – try to estimate lengths of animals not brought on board to the nearest 10 cm.

The following list provides a general rule of thumb for measurement types:

- Swordfish and billfish – lower jaw to fork length, curved (type 05C)
- Tunas, sharks & most other fish – straight fork length (type 01S)
- Rays – disc width (type 11S)

Weight types and measurements If the vessel is weighing fish, ask to access their weight information.

Weight type is also recorded as an alpha-numeric code (e.g. 01A)

using the following definitions:

- Blank - no weight **A** Actual
- 01** Whole **E** Estimated
- 02** Gilled & gutted
- 03** Gilled & headed
- 04** Headed & gutted
- 99** Other, describe in comment

Tag / specimen / carcass no. Record the tag, specimen or carcass number as appropriate. Complete the appropriate form as well.

Photos Check box if photos were taken and make notes in comments field.

Comment column Number comments consecutively within each set.

Comments box There is a comment box at the bottom of each 2nd page. Make any comments about individual animals or the haul here. Refer to individuals by their comment number.

Catch Composition - Pelagic Longline

Observer code *SLE 0001* Vessel code *12345* Trip ID *1* Set No. *1* Page 1 of _____

Hook No.	Species name	Species code	Caught condition code	Kept / return code	Damage code	Sex (M, F, I, U)	Type	Measurement	Type	Measurement	Type	Measurement	Type	Measurement	Tag / specimen no.	Photos	Comment
							Length 1		Length 2		Length 3		Weight				
3	<i>albacore</i>	<i>ALB</i>	<i>A1</i>	<i>K</i>		<i>I</i>	<i>01S</i>	<i>88</i>								<input type="checkbox"/>	
5	<i>bigeye</i>	<i>BET</i>	<i>A2</i>	<i>K</i>	<i>S</i>	<i>M</i>	<i>01S</i>	<i>101</i>								<input type="checkbox"/>	
1	<i>albacore</i>	<i>ALB</i>	<i>X</i>	<i>K</i>		<i>M</i>	<i>01S</i>	<i>98</i>								<input type="checkbox"/>	
5	<i>albacore</i>	<i>ALB</i>	<i>A2</i>	<i>K</i>		<i>F</i>	<i>01S</i>	<i>107</i>								<input type="checkbox"/>	
2	<i>blue shark</i>	<i>BSH</i>	<i>X</i>	<i>K</i>		<i>M</i>	<i>01S</i>	<i>193</i>								<input type="checkbox"/>	
4	<i>blue marlin</i>	<i>BUM</i>	<i>A1</i>	<i>A1</i>		<i>U</i>	<i>05E</i>	<i>175</i>								<input type="checkbox"/>	<i>1</i>
7	<i>bigeye</i>	<i>BET</i>	<i>A1</i>	<i>K</i>		<i>M</i>	<i>01S</i>	<i>129</i>								<input type="checkbox"/>	
4	<i>albacore</i>	<i>ALB</i>	<i>X</i>	<i>K</i>		<i>F</i>	<i>01S</i>	<i>111</i>								<input type="checkbox"/>	
6	<i>yellowfin</i>	<i>YFT</i>	<i>X</i>	<i>X</i>	<i>M</i>	<i>U</i>										<input checked="" type="checkbox"/>	<i>2</i>
1	<i>bigeye</i>	<i>BET</i>	<i>X</i>	<i>K</i>		<i>F</i>	<i>01S</i>	<i>136</i>								<input type="checkbox"/>	

Common Species SKJ Skipjack tuna YFT Yellowfin tuna BET Bigeye tuna ALB Albacore tuna SWO Swordfish BSH Blue shark SMA Shortfin mako shark	Caught condition A1 Active, not bleeding A2 Active, bleeding/obvious injury X Inactive U Unknown *More codes for MM & turtles	Kept/return codes K Kept A1 Active, not bleeding A2 Active, bleeding/obvious injury X Dead, inactive F Finned U Unknown	Damage codes Blank No damage NI Did not inspect C Cookie cutter shark M Marine mammal S Shark U Unknown source	Length types (combine # & letter) 01 Fork C Curved 02 Total S Straight 03 Standard E Estimated 04 Eye to fork 05 Lower jaw to fork 11 Disc width	Weight types (combine # & letter) Blank - no weight A Actual E Estimated 01 Whole 02 Gilled & gutted 03 Gilled & headed 04 Headed & gutted 99 Other, describe in comment
Sex codes M Male F Female I Indeterminate U Unknown (not inspected)					

Hook No.	Species name	Species code	Caught condition (A, D, I, U)	Kept / return code (K, A, D, F, I, U)	Damage code	Sex (M, F, I, U)	Type	Measurement	Type	Measurement	Type	Measurement	Type	Measurement	Tag / specimen / carcass no.	Photos	Comment
							Length 1	Length 2	Length 3	Weight							
7	Atlisailfish	SAI	A2	K		F	05C	187								<input type="checkbox"/>	
2	Blueshark	BSH	X	K		F	01S	244								<input type="checkbox"/>	
8	albacore	ALB	X	K		M	01S	117								<input type="checkbox"/>	
3	shortfinmako	SMA	X	I		F	01S	143								<input type="checkbox"/>	
3	bigeye	BET	X	K		F	01S	121								<input type="checkbox"/>	
4	yellowfin	YFT	U	K	C	F	01S	107								<input checked="" type="checkbox"/>	
5	yellowfin	YFT	X	K		F	01S	108								<input type="checkbox"/>	
1	Loggerhead	TTL	A1	A1		U								1		<input checked="" type="checkbox"/>	
7	bigeye	BET	A2	K		M	01S	103								<input type="checkbox"/>	
8	swordfish	SWO	A2	K		M	05C	126								<input type="checkbox"/>	

Comments (reference by number in comments box):

1 - blue marlin broke branchline & escaped before boarding
2 - no measure/sex because most of body missing (took photos of damage)

Version 1 - 30 Mar 2010

Figure 8-9 Example of completed Catch Composition form for pelagic longline.

8.7 Catch Composition and Biological Data

You are expected to monitor the entire haul for catch composition; however, occasionally this is not feasible. Use the following summary of problems/solutions to determine sampling modifications:

Fishing is too heavy to keep up without seriously impacting the vessel: If you are unable to keep up with the catch rate, reduce the number of sexed lengths collected to those indicated with the grey highlighted lines on the Catch Composition form for Pelagic Longline. This is approximately every third fish. The identification, catch condition and discard condition should still be collected for all individuals.

Seas are rough / too seasick to handle fish: If sea conditions make the deck too dangerous to work on, or if sea-sickness becomes severe, cease collecting measurements, but continue to monitor all hooks and record species caught. If sea conditions are too dangerous to remain on deck, you should make every effort to see each hook that comes up from a position of relative safety. These conditions are rare and impact your data quality. You should always document these situations in your Observer Logbook.

I need to use the toilet or eat a meal: If the haul time is more than 8 hours and the crew doesn't break at all, establish a random break system in order to take a meal or use the toilet. For instance, pick a random number between 1 and 12 which represent 5 minute increments on the clock. Every second hour during the randomly selected time, decide whether you need a break. Breaks should not exceed 15 minutes and should be limited to two per haul. You also need to devise a way to count hooks while on break in order to account for 'unmonitored

hooks'. Most of the time, you should be able to take care of your needs without missing any sampling.

Example: The haul begins at 1145 and is expected to take 10 hours. The random number is 4. At 1320, 1520, 1720, 1920, 2120, you could take a 15-minute break. During the break, you ask the crew to put all branchlines retrieved in a separate basket so that you can count them upon your return.

9 Purse Seine – Large Pelagics

9.1 Learning objectives

- Describe how purse seine gear works and how marine mammals can be released safely
- List the 4 forms that must be completed that are specific to purse seine vessels
- Describe the ‘preferred’ method for estimating total catch
- List 5 species that are a priority for length-frequency collection.

9.2 Introduction

In general, seining (including purse seine) accounts for about 30% of global fisheries catch (Watson et al. 2006). Purse seining is a method of fishing that uses a wall of net to encircle a school of pelagic fish. In most cases the purse seines are surface gears used in both coastal and high-seas waters. Aggregated resources in shallow depths are most common, but fish at depths up to 300 m can be targeted. Purse seines are also used in inland areas when there is enough room for the deployment of a large net. The purse seine can be operated by a large range of vessel sizes as well as by one or two boats. A wide range of pelagic fish sizes can be targeted ranging from sardines to tuna. Purse seiners are also used to fill aquaculture pens with bluefin tuna in joint fishing-aquaculture operations.

Because the target species are typically pelagic, there is virtually no impact on the bottom habitat (except when the water depth is less than the height of the seine during the fishing operations and that the lower edge of the gear wipes the sea bottom). The main negative impact of tuna purse seining is the incidental capture of dolphins in certain fishing areas (especially the eastern Pacific). Special techniques have been developed to reduce bycatch of dolphins (e.g., the Medina or dolphin safe panel and "back down" operation), which allow encircled dolphins to escape alive. When small pelagic purse seines are used with light attraction, there may be incidental catch/bycatch (including small fish, juveniles or endangered species). The practice of encircling floating objects, including man-made fish aggregating devices (FADs) increases the capture of small sized and immature fishes aggregating around such devices (FAO 2001-2009).

Data collection protocols for this chapter were compiled using observer manuals from established observer programs and papers published by observer data users (IATTC 1999-2005, Itano 2003, 2007, SPC 2007, Delgado de Molina et al. No date, Gaertner No date).

9.3 List of Priorities

1. Record vessel activity continuously each day on board;
2. Estimate total catch for each gear deployment;
3. Collect random samples for catch composition of each set and document species retained and discarded;
4. Describe all floating objects sighted, especially those involved in a fishing set;
5. Subsample catch for lengths;
6. Record all sightings and interactions with marine mammals and sea turtles;

7. Record fishing gear characteristics.

9.4 Gear Description

A purse seine is made of a wall of netting framed with a float line at the top and lead line toward the bottom (usually, of equal or longer length than the float line). The float line is held aloft by hundreds of small floats. The leadline is a weighted line to pull the net vertical and has purse rings hanging from the lower edge, through which runs a purse line made from steel wire or rope which allow the pursing (closing) of the net from below (Figure 9-1). Tuna purse seine nets can be more than 1km in length and 200m in depth (National Research Council Committee on Reducing Porpoise Mortality from Tuna Fishing 1992).

The basic equipment employed by industrial purse seine fisheries includes a net hauling system (e.g., single power block, duplex or triplex system, double block), a purse line winch (or capstan), a number of derricks or cranes, a brailer or a fish pump, small winches, several auxiliary boats and sometimes, an helicopter. Catch can exceed 100 MT. Net hauling systems come in a variety of styles and configurations. Auxiliary boats for tuna fisheries include a tow boat or net skiff used to pull the net from the vessel, speed boats used to herd tuna and/or dolphins and to prevent the net from collapsing during retrieval and a raft or personal watercraft used to assist with dolphin release.

The backdown procedure is the principal marine mammal release maneuver. The vessel starts to reverse after approximately one half to two-thirds of the net has been rolled aboard and is tied down. This creates a channel and causes the corkline at the apex (section furthest from the ship) to sink, thus allowing captured marine mammals to escape without losing the tuna catch (Figure 9-2). Occasionally, rafts and swimmers are deployed to herd marine mammals toward the release area.

The dolphin safety panel consists of a small-mesh net strip installed in place of the standard mesh. When correctly installed and aligned, it covers the perimeter of the backdown channel created by the backdown procedure, and reduces the likelihood of marine mammal entanglement.

9.4.1.1 Floating Objects and Fish Aggregating Devices

Tuna are sometimes associated with floating objects or flotsam of natural (e.g., trees) or human (e.g., fish aggregating device or garbage) origin. Floating objects can be drifting with the ocean currents or anchored to one location. Detailed information will be collected on sightings of and vessel interactions with floating objects (Floating Object Record form) in order to quantify this association and determine the distribution and abundance of the objects in the East Atlantic Ocean. Nets can be deployed near these floating objects as well.

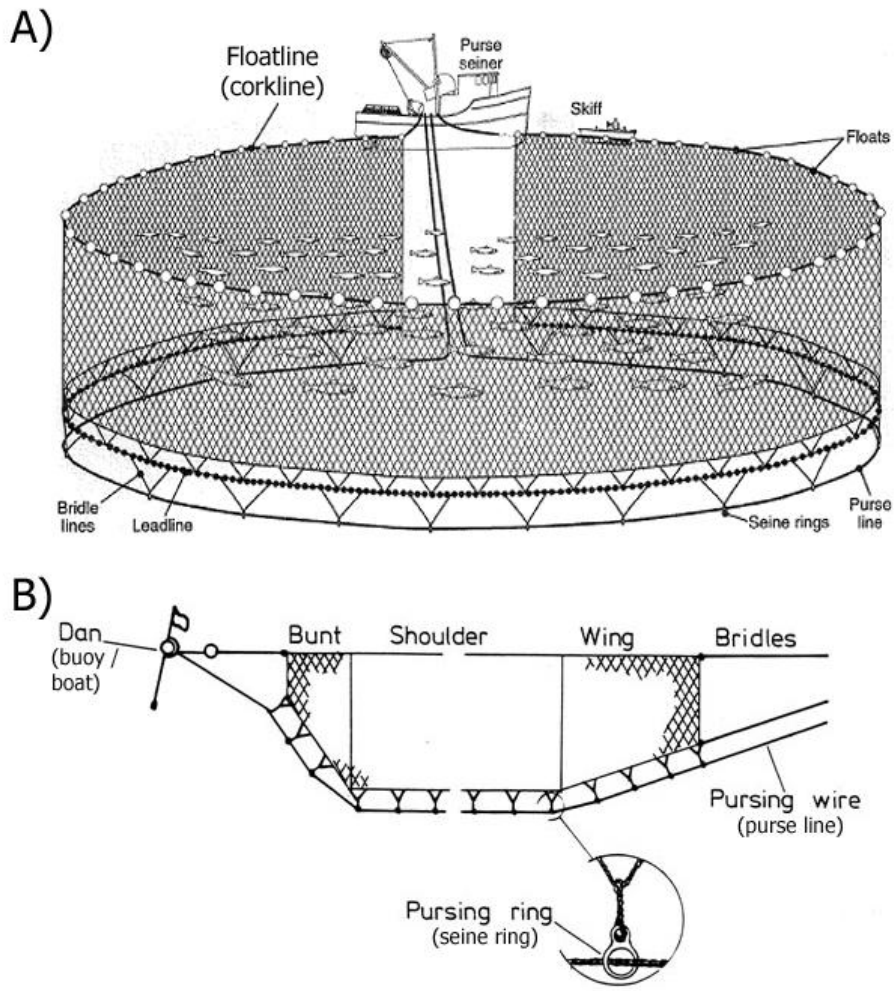

Figure 9-1 Generalized purse seine configuration without (A) and with (B) tapered ends. Images modified from (Hanrahan et al. 1997, FAO 2001-2009).

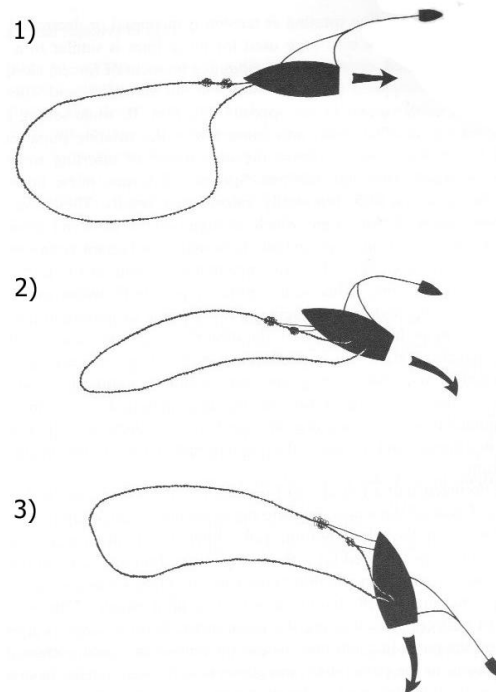

Figure 9-2 Diagram of backdown procedure to release dolphins. Modified from (National Research Council Committee on Reducing Porpoise Mortality from Tuna Fishing 1992).

9.5 Fishing Description

Locating Fish: Searching for fish is an important component of fishing effort. Tuna purse seiners utilize a number of methods to locate fish including aircraft (land-based planes or ship-based helicopters), high powered binoculars (20X) from the bridge or crow's nest, or radar to search the sea for cues of fish presence. Cues may include schools of tuna (breezers, boilers and black spots), schools of small fish, flocks of birds, ruffling of the water surface and presence of groups of dolphins or whales. Prior to deploying a net, vessels must evaluate school size and catchability (National Research Council Committee on Reducing Porpoise Mortality from Tuna Fishing 1992). Speedboats may be used to herd fish or marine mammals prior to gear deployment.

Gear Deployment: Another type of small motorized boat (tow boat or net skiff) is deployed first. One end of the net is then lowered and attached to the skiff. The seiner and skiff then proceed to encircle the fish with the net (also called casting). Casting is fairly quick, 5-15 minutes. When fully deployed, the seine hangs in the water similar to a gillnet. The mesh size is generally small enough that fish do not become entangled in the net, rather they are contained by the encircling net.

Gear Retrieval: Once the netting has totally encircled the fish, the purse line is winched in, closing the bottom of the seine (also called pursing). The seine is pulled aboard the seiner by the purse line and headline, reducing space inside the net and concentrating the fish in one section of the net (sometimes called the sack or bunt). Pursing may take 15-25 minutes. The catch is winched aboard with brailers (or dip nets) or sucked aboard with a hydraulic pump

(small pelagic fish only). Getting all of the fish on board may take 4-5 hours depending on catch size (Kim et al. 2005).

9.6 Forms/Instructions

9.6.1 Gear Description Form

Complete one gear description form for each unique net on board during your trip (Figure 9-6).

Page ___ of ___ Insert the page number and total number of pages. This will be “1 of 1” if there is only one net.

Observer Code: Record your observer identification code (assigned by the SOP).

Vessel Code: Record the vessel code (Appendix 3).

Trip ID Enter the trip identification number assigned by the SOP.

Net hauling system Make a brief description and record the manufacturer and model of the net hauling system including any power blocks.

Purse line winch Record the make and model of the power winch or capstan used to bring in the purse line.

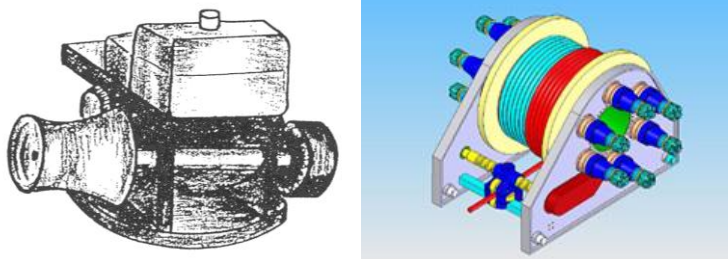

Capstan (left) and purse line winch (right; <http://www.cmtwinches.com>)

Brail capacity Record the capacity (in metric tons) of each brailer used to transfer fish from the net onto the vessel. Ask the captain for the capacity. The capacity can be used for one method of total catch estimation.

Net Characteristics

Net # Enter “1” if only one net or identical nets are used. If more than one net is used and they are not identical, complete a second form and complete the relevant sections for Net #2.

Total length Record the total length of the net in meters. To determine the length of the net, count the number of handholds in the corkline from end to end during 3 gear deployments, using a hand counter to keep tally. Record the average length to the nearest whole meter. Handholds are the spaces between groups of corks in the floatline, and are generally ~ 2 meters apart. Ask to measure a few to get an idea of this distance.

Total length = total count of hand holds * average distance between handholds. If there are no obvious sections or if sections are too long to measure, ask captain for the net dimensions.

Total depth Net depth can be determined by counting the number of net strips (at the center line if possible). Each strip is approximately 2 meters (stretched mesh) deep, and the join between strips can be identified by the line of lacings holding the edges together. Calculate the net depth in meters by multiplying the number of strips by the height of one strip.

Float line length Record the length of the float line in meters. Captain can provide this measurement.

Lead line length Record the length of the lead line in meters. Captain can provide this measurement.

Mesh size & type Record mesh size in centimeters. Calculate using the average of 20 stretched meshes (the distance between opposite mesh knots when the mesh is stretched tight; Figure 9-3)7. Record the average mesh size to the nearest tenth of a centimeter.

Circle appropriate letter for whether the mesh size was measured **Wet** or **Dry**. Ideally, this measurement should be made when the net is wet.

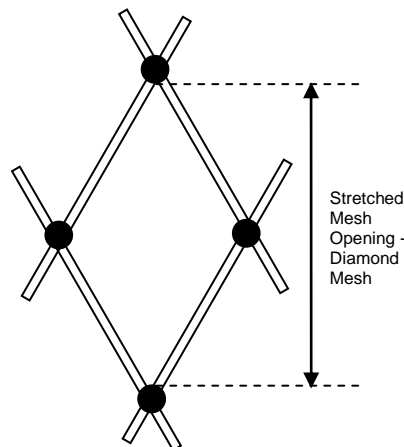

Figure 9-3 Measure stretched mesh opening from the inner edge of knots (modified from (Ferro and Xu 1996)).

Circle whether the mesh type was knotted or knotless (



Figure 9-4 Knotted (left; <http://www.battingnets.com/analysis>) and knotless (right;

<http://www.nguinternational.com/fishing/nets.htm>) mesh.

Hanging ratio	Ratio of float line length to netting length (typically ~.8). There may be different ratios for the float and lead lines. Ask captain.
Purse line material	Record the material of the purse line (e.g., steel cable, Spectra™)
Purse line diameter (mm)	Record the diameter of the purse line in millimeters. Ask the captain or crew.

Dolphin Safety Panel – Complete this section only if the net is equipped with this panel.

Length	Measure this on three separate occasions, using the same method as described for determining total net length (see above). You can combine one measurement with your total net length measurement if you make a note of where the safety panel begins and ends while measuring the entire net. The ends of the safety panel may be marked with paint or buoys.
Depth	Determine the depth of the safety panel by counting the number of fine mesh strips, as for total net depth. Usually 2-3 strips.
Mesh size	Measure and record the mesh size of the netting in the safety panel, as for net mesh size (above).
Net Diagram	Make a generalized sketch of the net, indicating the approximate dimensions and location of the principal components. Net shapes are highly variable (Figure 9-5). Include the overall dimensions of the net and safety panel, the approximate positions of bunch lines, and the position of markers on the corkline identifying tie-down points, the ends of the safety panel, and/or the apex of the backdown channel.

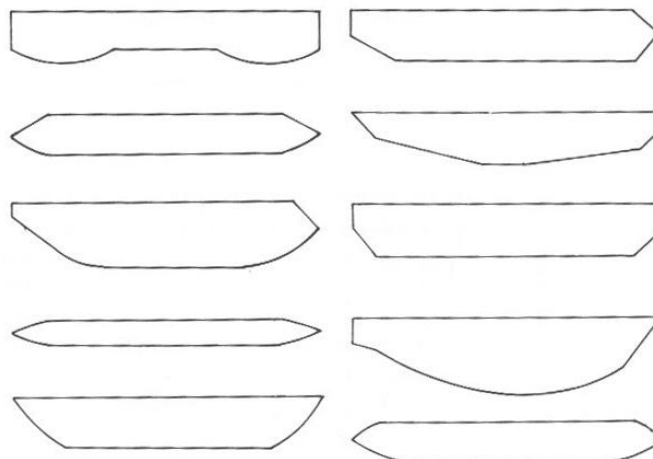

Figure 9-5 Purse seine shapes. Modified from Ben-Yami (1994)

Comments

Note the general condition of the net and safety panel including any details such as holes or tears in the webbing, loose corkline hangings, and any other information pertinent to the operation of the net or fishing efficiency.

Describe the brailing operation. This should include: how the mouth of the net was held open (i.e. with the skiff or by a boom); design of the actual brail (long or short handle, no handle, x-shaped, etc.); is the brail linked to a boom or the purse davit; etc.

Gear Description - Purse Seine

Observer code 175	Vessel code XYZ 388	Trip ID 00279	Page <u>1</u> of <u>1</u>		
	Description	Manufacturer	Model	Brail capacity (MT)	
Net Hauling system	<i>double block</i>	<i>Fiorentino</i>	<i>Wide Shell 56inch</i>	Primary	0.75
				Secondary	0.5
Purse line winch		<i>Westec</i>	<i>TW-8063</i>	Secondary	
Net Characteristics					
Net #: 1		Total length (m): 160		Total depth (m): 40	
Float line length (m): 170		Lead line length (m): 170			
Mesh	Size (cm)	7.2 W / D		Hanging Ratios	
	Type (circle one)	Knotted / Knotless		Float line: 0.85	Lead line: 0.85
Purse line material	<i>Duralon</i>		Purse line diameter (mm)	25	
Dolphin Safety Panel					
Total length (m):		Total depth (m):			
Mesh size (cm)	W / D				
Net diagram					
Comments					
<p><i>Net was well maintained (no obvious holes/tears); Net was held open by the skiff and fish were brailed on board with a few exceptions. Brailer had a handle to aid maneuverability. Brailer was attached to a knuckle crane. Fish were brailed directly onto the tender vessel on two occasions (see logbook pages 37 and 55).</i></p>					
Version 1.0 6/2010					

Figure 9-6 Example of Gear Description form for purse seine.

9.6.2 Daily Activity Log

All of the vessel's activities are accounted for on the Daily Activity Log (DAL). These activities include fishing, searching effort, and marine mammal sightings. The majority of the observer's non-fishing time on a tuna purse seine vessel will be on the bridge documenting

activities. The information recorded on this form is primarily used for estimating fishing effort and for analyzing the distribution of marine mammals.

The DAL should be filled out continuously throughout the entire trip. Event codes define specific vessel activities as well as documenting an assortment of sighting cues for tunas. Each event code requires you to complete a different set of fields (Figure 9-7).

A new entry must be made on the DAL for each new event, or whenever one of the following changes occurs; in such cases enter the same event code as before, followed by the relevant data items (Figure 9-7 and Figure 9-8):

- Change in the observer's effort status (e.g., you break for lunch or leave observation post for >5 minutes);
- Change of one knot or more in vessel speed;
- Change in the number of high-powered binoculars in use;
- Change in sea-state conditions (Beaufort) during a SEARCH event;
- Recording a position at least every **two** hours while the vessel is underway (SEARCH or RUN);
- Recording a water temperature at least every **four** hours while the vessel is underway (SEARCH or RUN).

On Effort?	Event	Date/Time				Position					Beaufort	Weather	Obs. Condition	Water Temp	Speed	No X20	Aerial Assist	MM Sighting No.	Set No.	Float Object No.
		Day	Month	Year	Time (24-hr)	Lat-Deg	Lat-Min	Lat-N/S	Long-Deg	Long-Min										
	Port																			
	Run																			
	Search																			
	Cue-all types																			
	Heli Depart																			
	Heli Return																			
	Mammal																			
	Chase																			
	Start set																			
	Net cleaning set																			
	Investigate-free school																			
	Float object-investigate, deploy or retrieve																			
	Drift - Break down, night, or lights																			
	Drift - floating object																			
	Bad weather																			
	Transship/bunkering																			
	Other Fishing																			

Figure 9-7 Complete the highlighted data fields for each event type. Light grey indicates fields that are only necessary if a marine mammal sighting or floating object are associated with a setting event.

The DAL fields are defined as follows:

Field	Definition
-------	------------

Observer Code:	Record your observer identification code assigned by the SOP.
----------------	---

Vessel Code:	Record the vessel code (Appendix 3).
--------------	--------------------------------------

Trip ID	Enter the trip identification number assigned by the SOP.
On Effort?	<p>This column quantifies your effort in watching for and recording vessel activity and marine mammal sightings; it is not meant to act as a time card, but as a measure of when high quality data is being collected. You are ON EFFORT when you are on or near the bridge in order to observe the vessel's operations and to collect data on marine mammal sightings; you are not ON EFFORT if you are away from your observation post for more than five minutes. The time you are ON EFFORT is a subset of the time that the vessel is searching and running; therefore, enter Y (Yes) or N (No) in the ON EFFORT? Column each time you make a SEARCH or RUN event entry. If you change your effort status while the vessel is in either SEARCH or RUN, re-enter the event code with the appropriate ON EFFORT? status.</p> <p>For example, suppose the vessel began searching at 0600, but you did not go to the bridge until 0630. You would enter the DATE, code "3" in the EVENT column, "N" in the ON EFFORT? column, "0600" in the TIME column, and any other required data items in their respective columns. You then enter "3", Y, 0630, and any other required data items, to indicate that you were on the bridge and able to collect accurate sighting data. Later on, if the vessel is still searching and you leave your observation post at 1200 hours and return at 1300 hours, you would enter the following:</p> <ol style="list-style-type: none"> 1) "3", N, 1200, plus any other required data; and 2) "3", Y, 1300, plus any other required data.
Event	<p>Record the appropriate event code for each event. There are 25 event types defined as follows:</p> <ol style="list-style-type: none"> 1. PORT – record "1" any time your vessel is in a port (anchored or at a dock). In addition to date, time and position, write the name of the port city or location to the right of position. Only RUN or SEARCH events can follow the PORT event code. 2. RUN - Enter code "2" if the vessel is under way for at least 5 minutes, is following a set course, and no crew member is looking for signs of fish with binoculars and/or the bird radar is not monitored. 3. SEARCH - Enter code "3" if the vessel is under way, following a set course for at least 5 minutes and any crew member is looking for signs of tuna with binoculars and/or bird radar. Enter "3" if no crew members are using binoculars but someone is manning the bird radar; do not enter SEARCH if the helicopter is airborne but no crew member is stationed

on the binoculars and/or bird radar. If in SEARCH mode for >2 hours, record a new position, weather conditions, water temp and speed.

4A-E. There are five CUES that may indicate the potential for tuna:

4A. **BIRDS** – a flock of birds is either sighted by eye or via the bird radar;

4B. **SPLASHES** – splashing at the surface can precede a marine mammal sighting or fish at the surface

4C. **BREEZER** – fish subsurface have the effect of making water look like a breeze is blowing

4D. **FLOATING OBJECT** – the initial sighting of a floating object may lead to investigating a floating object

4E. **OTHER** –can include cues of any kind reported by another vessel. Record the circumstances at the foot of the page. If the other vessel reports the presence of marine mammals, enter OTHER until the MM can be sighted from your vessel. Then record as MM sighting.

5A. **Heli Depart** - Record time and position when helicopter departs to search for fish.

5B. **Heli Return** - Record the time and position when helicopter returns from search.

6A. **MAMMAL** - Enter code “6A” every time you or any crew member, on the vessel or from the helicopter, first sights marine mammals, with or without the aid of a cue. There should be a separate mammal sighting form for each species sighted (Section 11.4.1).

6B. **CHASE** - Enter code “6B” when the first speedboat hits the water to pursue marine mammals or whenever the vessel itself begins herding marine mammals (the latter is more common when pursuing a whale).

7. **START SET** - Start set begins when net skiff is deployed into the water and begins pulling purse seine from the vessel.

8. **Net cleaning set** - If the net is set for any other reason other than to catch tuna (trial set, net cleaning), enter "8".

9. **Investigate free school** of tuna

10 A-C. **Floating object** – there are three types of floating object events. Enter the time and position for all types and also complete a Floating Object Record.

- 10A. **Floating object – Investigate.** If a vessel approaches a floating object within 250m, record as “10A”.
- 10B. **Floating object – Deploy** – Use “10B” when your vessel deploys a floating object.
- 10C. **Floating object - Retrieve** – Use “10C” when your vessel retrieves a floating object.
- 11A. **Drift - Break down** – Use “11A” when a vessel is drifting due to a mechanical problem.
- 11B. **Drift – night** – Use “11B” when a vessel drifts at night.
- 11C. **Drift – with floating object** – Use “11C” when a vessel is drifting with a floating object. You must also complete a Floating Object Record for this event.
- 11D. **Drift – with fish aggregating lights** – Use “11D” when a vessel is adrift and is using lights to attract fish to the vessel.
12. **Bad weather** – Record “12” if vessel is drifting or hove to due to bad weather.
13. **Transship/bunkering** - Stops to transfer fuel or supplies with another vessel. If your vessel receives fish from another boat while at sea or offloads its catch to another vessel, record the vessel name, registration number, IRCS, and amount of fish received by species in the Daily Notes section of the Observer Logbook.
14. **Other fishing** - Make notes in Observer Logbook if the vessel uses fishing gear other than a purse seine.

Date	Record date for the first event of each day including the day you board. There is a separate column for day, month and year. Record 2-digits in each column (e.g. 01.05.10 for Day.Month.Year).
Time (24-hr)	Record time using 24-hr notation (e.g., 8:45 a.m. = 0845 and twelve minutes past two in the afternoon = 1412).
Lat-Deg	Record degrees of latitude (2-digits).
Lat-Min	Record the minutes of latitude (to tenths of a minute; 3-digits e.g. 47.6)
Lat-N/S	Record N for all latitudes North of the equator and S for latitudes south of the equator.

Long-Deg	Record degrees of longitude (3-digits) for start and end of each haul.
Long-Min	Record the minutes of longitude (to tenths of a minute; 3-digits e.g. 24.4)
Long-E/W	Record W for all longitude West of the prime meridian (i.e., 0°) and E for longitudes east of the prime meridian.
Beaufort	The Beaufort system uses sea state as a criterion for measuring wind speed (Appendix 12). If the sea state changes while the vessel is searching, re-enter SEARCH, a position, the new Beaufort state, and the other required data items. If the vessel is running, you need only record a change in Beaufort number, a position, and the other required data if you are ON EFFORT.
Weather	Weather codes: 0 - <50% Clouds 1 - >50% Clouds 2 - patchy fog 3 - solid fog 4 - mist / light rain 5 - med / heavy rain 6 - fog & rain 7 – snow
Obs. Cond.	Record the Observation Condition of the view 180° ahead of the vessel. This code is a combination of one letter and one number relating to visibility (letters) and glare (numbers) defined below: Visibility E Excellent: visibility is completely clear to the horizon; calm conditions; would easily detect a bird >300m from vessel G Good: sighting conditions may be affected by glare, sea state, weather or distance; a small bird would be detected to 300m and a mammal at >1 km F Fair: conditions affected by a combination of problems such as heavy seas, poor weather or distance; a small bird would be detected to 200m P Poor: severely limited visibility (<200m) due to high seas, weather such as fog. Glare 0 None

- 1 Slight / grey (light)
- 2 Bright / 1 side (moderate)
- 3 Bright / forward (harsh/reduces visibility significantly)

Observation Condition codes modified from Kuletz et al.(2008).

Water Temp Enter the surface water temperature, in Celsius, to the nearest tenth of a degree, or half a degree, depending on the type of thermometer used. Record the water temperature for every set, and at least once every four hours during the day when the vessel is running or searching. You are not required to record water temperature during drifts.

NOTE: When taking a temperature reading, be careful not to strike the thermometer against the side of the hull. Avoid taking the temperature near the warm water outlets from the engine cooling system.

If you are not issued a thermometer, use the ships thermometer for this data field.

Speed Record the speed of the vessel in knots (tenths) with every SEARCH event and with RUN events when: 1) the RUN event is the first event of the day, or 2) the speed changes by one knot or more.

No. X20 Record the number of pairs of high-powered binoculars (20X or stronger), low power binoculars and bird radar in use and in this order of priority. Enter **P1** if one pair is in use, **P2** for two pairs, and so on. If only low-powered binoculars (less than 20X) are being used, enter **P0** in this column. If only the bird radar (no binoculars) is being used to look for fish, enter **RAD**. If one pair of high-powered binoculars are used in addition to radar, the code is still P1. If the number of high-powered binoculars in use changes, re-enter SEARCH event code, the time, and the new No.X20 code.



Binocular power: Binoculars usually have two numbers associated with them in an A x B format (e.g., 7x56 or 25x100). The first number refers to the magnification and is the number used for determining high-powered status for this data field. The second number refers to the objective lens diameter and is a proxy for the amount of light coming through the lens.

Aerial Assist If a helicopter or plane aided the vessel at any time during the chase and/or set, enter **Y** (Yes), even if your vessel does not carry a helicopter. Enter **N** (No) if an aircraft was not used at any point during the chase and/or set.

To ascertain whether the helicopter is being used to chase or herd marine mammals, listen to the radio transmissions between the boat and the helicopter, or ask the pilot or spotter after the set.

MM Sight No. Each marine mammal sighting is assigned a consecutive number starting with "1" for the first marine mammal sighted during the trip. This number identifies the sighting, the "CUE" which led to the sighting and the subsequent chase and set (if applicable) made on the marine mammals.

Set No. Enter a new consecutive set number every time the vessel makes a set with the intent to catch fish.

Float Object No. Enter a new consecutive floating object number for each unique floating object sighted, investigated, deployed and retrieved. This object number should match the Floating Object Record. If you encounter the same floating object, use the floating object number already used but complete a new floating object record form for each additional sighting with this object.

Daily Activity Log - Purse Seine - Large Pelagics																						
Observer code 175		Vessel code XYZ 388					Trip ID 00279		Page 1 of													
On Effort?	Event	Date/Time				Position							Beaufort	Weather	Obs. Cond.	Water Temp	Speed (kn)	No X20	Aerial Assist	MM Sight No.	Set No.	Float Object No.
		Day	Month	Year	Time (24-hr)	Lat-Deg	Lat-Min	Lat-N/S	Long-Deg	Long-Min	Long-E/W											
	1	13	12	09	0600	08	29.9	N	013	12.5	W	Board vessel in Freeport (SLE) harbor										
N	2				0805	08	29.9	N	013	12.5	W	1	0	E0	##	9						
N	2				1005	08	27.6	N	013	30.6	W											
Y	2				1205	08	25.8	N	013	47.9	W	2	0	E0	##	9.0						
Y	3				1345	08	21.2	N	013	58.9	W	2	0	E0	##	9.0	P1					
Y	3				1545	08	15.5	N	014	20.1	W											
Y	3				1735	08	13.5	N	014	30.7	W	2	0	E1	##	9.0	P1					
	4A				1802			N			W						P1					
	7				1830	08	12.9	N	014	47.5	W	2	0	E0	##			N		1		
	11B				2135	08	13.1	N	014	47.5	W											
								N			W											
								N			W											

Event Codes

- 1 Port
- 2 Run
- 3 Search
- 4A Cue-birds
- 4B Cue-splash
- 4C Cue-breezer
- 4D Cue-Floating object
- 4E Cue-Other
- 5A Heli Depart
- 5B Heli Return
- 6A Mammal
- 7 Start set
- 8 Net cleaning set
- 9 Investigate-free school
- 10A Float object-investigate
- 10B Float object-deploy
- 10C Float object-retrieve
- 11A Drift - Break down
- 11B Drift - Night
- 11C Drift - floating object
- 11D Drift - lights
- 12 Bad weather
- 13 Transship/bunkering

Weather Codes

- 0 <50% Clouds
- 1 >50% Clouds
- 2 patchy fog
- 3 solid fog
- 4 mist/ lightrain
- 5 med /heavy rain
- 6 fog & rain
- 7 snow

Observation Condition

Visibility

- E Excellent
- G Good
- F Fair
- P Poor

Glare

- 0 None
- 1 Slight/ grey (light)
- 2 Bright/ 1 side (moderate)

No. X20 Codes

RAD Bird radar only

- P0 <20x binocs
- P1 1 20x binocs
- P2 2 20x binocs
- P3 3 20x binocs

Page ____ of ____

On Effort?	Event	Date/Time				Position						Beaufort	Weather	Obs. Cond.	Water Temp	Speed (kn)	No X20	Aerial Assist	MM Sighting No.	Set No.	Float Object No.
		Day	Month	Year	Time (24-hr)	Lat-Deg	Lat-Min	Lat-N/S	Long-Deg	Long-Min	Long-E/W										
N	3	14	12	09	0600	08	12.9	N	014	47.5	W										
Y	3				0635	08	12.1	N	014	47.6	W	2	1	G1	##	9.2	P2				
Y	3				0835	08	11.5	N	014	48.7	W	2	1	G1		9.2	P2				
Y	3				1035	08	8.4	N	014	51.1	W	3	1	F1	##						
	6A				1102	08	8	N	014	51.2	W						P2	N	1		
Y	3				1235	08	6.8	N	014	52.2	W	3	1	F1		9.2	P2				
Y	3				1430	08	5.3	N	014	52.3	W	3	1	F1	##	9.2	P1				
	10A				1440	08	5.3	N	014	52.3	W										1
	7				1500	08	5.3	N	014	52.3	W				##			N		2	1
	11C				1700	08	5.4	N	014	52.3	W										1
								N			W										
								N			W										
								N			W										
								N			W										
								N			W										
								N			W										
								N			W										
								N			W										

Version 1 - 10 Dec 2009

Figure 9-8 Daily Activity Log example.

9.6.3 Floating Object Record

Complete the Floating Object Record (FOR) each time a floating object is investigated, deployed, retrieved or a set is made within 250 meters of a floating object (Figure 9-9).

A very important feature of the FOR is that it enables an object to be tracked throughout a trip, by means of the Object No. and Sighting No. recorded in the form header. When an object is sighted for the first time during a trip, it is assigned a unique number, the Object No., which is used for that object throughout the trip; the Sighting No. is a sequential number used to track each visit to a particular object during the trip. A new sighting number should be assigned if your vessel has left and returned to the same object. If the vessel drifts near an object overnight and a new FOR was completed the night before, continue with the same sighting number the next day.

- Field** **Definition**
- Observer Code: Record your observer identification code.
- Vessel Code: Record the vessel code (Appendix 3).
- Trip ID Enter the trip identification number assigned by the SOP.

Object No.	Record a new Object No. for each unique floating object sighted.
Sighting No.	Record consecutive Sighting No. for additional sightings of the same object. If the vessel has not left the object, do not start a new sighting no.
Set No.	If a set is made on the floating object, record the associated set number.
Components	<p>This section is used to record the components that make up a floating object, and to track any changes in these components. The most common materials which make up the majority of floating objects are listed, and two columns, 'As found' and 'As left', are used to record the components which make up the object when the vessel encounters it ('As found') and when it leaves it adrift ('As left'). If a dead animal is intentionally attached to the object to attract prey, write its species code in the space provided. If the object has a component not included in the list, check Other and provide a description in the space provided.</p> <p>If net material is one of the components, try to estimate the dimensions and predominant mesh size.</p>
Locating equipment	Check all types of locating equipment present at the floating object when you found it (As found) and when you leave (As left).
Prior origin of object	<p>This section is used to document the origin of the object prior to the current encounter.</p> <p>Your vessel – this trip - The object was encountered by your vessel previously during this trip.</p> <p>Your vessel – previous trip - The object was set adrift by your vessel during a previous fishing trip. This information must be obtained from the crew.</p> <p>Deployed -The object is either (a) being placed in the water for the first time, or (b) returned to the water after being taken aboard the vessel and moved to another area.</p> <p>Other vessel – with owner consent - The object belongs to another vessel, and its location has been given to your vessel with the owner's permission.</p> <p>Other vessel – without owner consent - The object belongs to another vessel, and has been found by your vessel without the permission or collaboration of the owner.</p>

Drifting object found - The object was not previously involved in fishing activity. If the object has signs of previous fishing activity, such as a flag or beeper attached, record it as Other vessel – no owner consent.

Unknown - You cannot determine the prior origin of the object.

Other - Check this box if you can determine the origin of the object, and none of the other options in this section apply. Record the origin in the space provided, and note any details in COMMENTS.

Locating method Check the **primary** method used to locate the object. If the object is a FAD being deployed, check Not applicable, since it was not located.

Radar - The object or associated birds were detected using radar equipment.

Direction finder - The object was located using a directional beeper signal.

Satellite - The position of the object was determined via satellite (GPS).

Visual – the object itself - The object was sighted directly or with X20 binoculars.

Visual – birds- Birds sighted directly or with X20 binoculars led to the detection of the object.

Not applicable - The object was transported to the area and placed in the water (deployed).

Unknown - You were unable to determine the method used to find the object.

Other - If none of the above is applicable, describe the method used to find the object in the space provided.

Other Data

Bait container attached?

If the vessel attached a bait container, check **Yes**. If no bait container was attached, check **No**. If you are not sure, check **Unk** and note any details in COMMENTS.

Bait container refilled?

If the object has a bait container when found, check **Yes** if it is refilled, **No** if it is not. If you are not sure, check **Unk** and note any details in COMMENTS. If the object has no bait container,

check **NA** (not applicable).

Fauna entangled?

Check **Yes** if any fauna, dead or alive, is entangled in the object. Write the name or species codes of the entangled fauna in the space provided. If you are not sure because you could not see entire object, check **Unk**.

Check the appropriate box for whether the floating object was **Anchored** or **Drifting**.

Water clarity

Check the box which most closely describes the clarity of the water (Clear, Turbid or Very turbid).

% biota

Record your estimate of the percentage of the object which is covered in living material (e.g. invertebrates or algae). If you cannot see the object well enough to estimate, leave blank.

Tag number

If the object carries a tag attached as part of a tracking program (**NOT** a marker or identifier placed by a fishing vessel), record the identification number of the tag in the space provided, and note any details in **COMMENTS**. **Do not remove the tag from the object.**

Overhead &
Side view
diagrams

Use this space to make two sketches of the object. One should be a bird's-eye view of the object, with dimensions (in meters), and shaded to show the extent and density of epibiota or other organic material. The other should be a side view of the object, similarly shaded, showing the angle at which it is floating in the water, with dimensions both above and below the waterline. If the object is irregularly shaped, draw an imaginary box around it, and give the length, width, and height of the box. If the object is submerged, record the depth at which it is floating. If you cannot see enough of the object to draw a side view, draw as much as you can and make a note.

Comments

Record any other information not included in the previous sections. Use this space, and a separate sheet of paper if necessary, for notes on additional species of flora or fauna not included on the form due to lack of space or lack of a suitable code. Also include notes on previous fishing activity (e.g., beeper or flag attached) and any other information which would help trace previous sightings of this log.

Birds associated with floating object?

Floating Object Record

Page 1 of

Observer code 175	Vessel code XYZ 388	Trip ID 00279	Object No. 1	Sighting No. 1	Set No. 2
-----------------------------	-------------------------------	-------------------------	------------------------	--------------------------	---------------------

Components (check all that are applicable)			Prior origin of object (check one)	
	As found	As left		
Tree	<input type="checkbox"/>	<input type="checkbox"/>	Your vessel - this trip	<input type="checkbox"/>
Dead animal _____	<input type="checkbox"/>	<input type="checkbox"/>	Your vessel - previous trip	<input type="checkbox"/>
Chain/cable/rings/weights	<input checked="" type="checkbox"/>	<input checked="" type="checkbox"/>	Other vessel - with owner consent	<input type="checkbox"/>
Cane/bamboo	<input type="checkbox"/>	<input type="checkbox"/>	Other vessel - without owner consent	<input checked="" type="checkbox"/>
Bait container / bait	<input type="checkbox"/>	<input type="checkbox"/>	Drifting object found	<input type="checkbox"/>
Cord / rope	<input checked="" type="checkbox"/>	<input checked="" type="checkbox"/>	Unknown	<input type="checkbox"/>
Floats / corks	<input checked="" type="checkbox"/>	<input checked="" type="checkbox"/>	Other _____	<input type="checkbox"/>
Artificial light for attracting fish	<input type="checkbox"/>	<input type="checkbox"/>		<input type="checkbox"/>
Netting material	<input type="checkbox"/>	<input type="checkbox"/>		<input type="checkbox"/>
Sacks / bags	<input type="checkbox"/>	<input type="checkbox"/>		<input type="checkbox"/>
Planks / pallets / plywood / spools	<input type="checkbox"/>	<input type="checkbox"/>		<input type="checkbox"/>
Metal drum / plastic drum	<input type="checkbox"/>	<input type="checkbox"/>		<input type="checkbox"/>
PVC or other plastic tubes	<input type="checkbox"/>	<input type="checkbox"/>		<input type="checkbox"/>
Plastic sheeting	<input type="checkbox"/>	<input type="checkbox"/>		<input type="checkbox"/>
Unknown	<input type="checkbox"/>	<input type="checkbox"/>		<input type="checkbox"/>
Other _____	<input type="checkbox"/>	<input type="checkbox"/>		<input type="checkbox"/>
			Locating method (check one)	
			Radar	<input type="checkbox"/>
			Direction finder	<input type="checkbox"/>
			Satellite	<input type="checkbox"/>
			Visual - the object itself	<input checked="" type="checkbox"/>
			Visual - birds	<input type="checkbox"/>
			Not applicable	<input type="checkbox"/>
			Unknown	<input type="checkbox"/>
			Other _____	<input type="checkbox"/>
			Other data	
				Y N NA Unk
			Bait container attached	<input checked="" type="checkbox"/>
			Bait container refilled	<input checked="" type="checkbox"/>
			Fauna entangled	<input checked="" type="checkbox"/>
			Locating equipment (check all applicable)	
	As found	As left		
Flag	<input checked="" type="checkbox"/>	<input checked="" type="checkbox"/>		
Satellite buoy	<input type="checkbox"/>	<input type="checkbox"/>		
Buoy, corks, etc	<input checked="" type="checkbox"/>	<input checked="" type="checkbox"/>		
Lights	<input type="checkbox"/>	<input type="checkbox"/>		
Radio transmitter / beeper / beacon	<input type="checkbox"/>	<input type="checkbox"/>		
Radar reflector	<input type="checkbox"/>	<input type="checkbox"/>		
Unknown	<input type="checkbox"/>	<input type="checkbox"/>		
Other _____	<input type="checkbox"/>	<input type="checkbox"/>		
			Check one: <input checked="" type="checkbox"/> Anchored <input type="checkbox"/> Drifting	
			Water clarity: <input checked="" type="radio"/> Clear / <input type="radio"/> Turbid / <input type="radio"/> Very turbid	
			% biota <input <="" td="" type="text" value=" <5% "/> <td>Tag Number <input type="text"/></td>	Tag Number <input type="text"/>

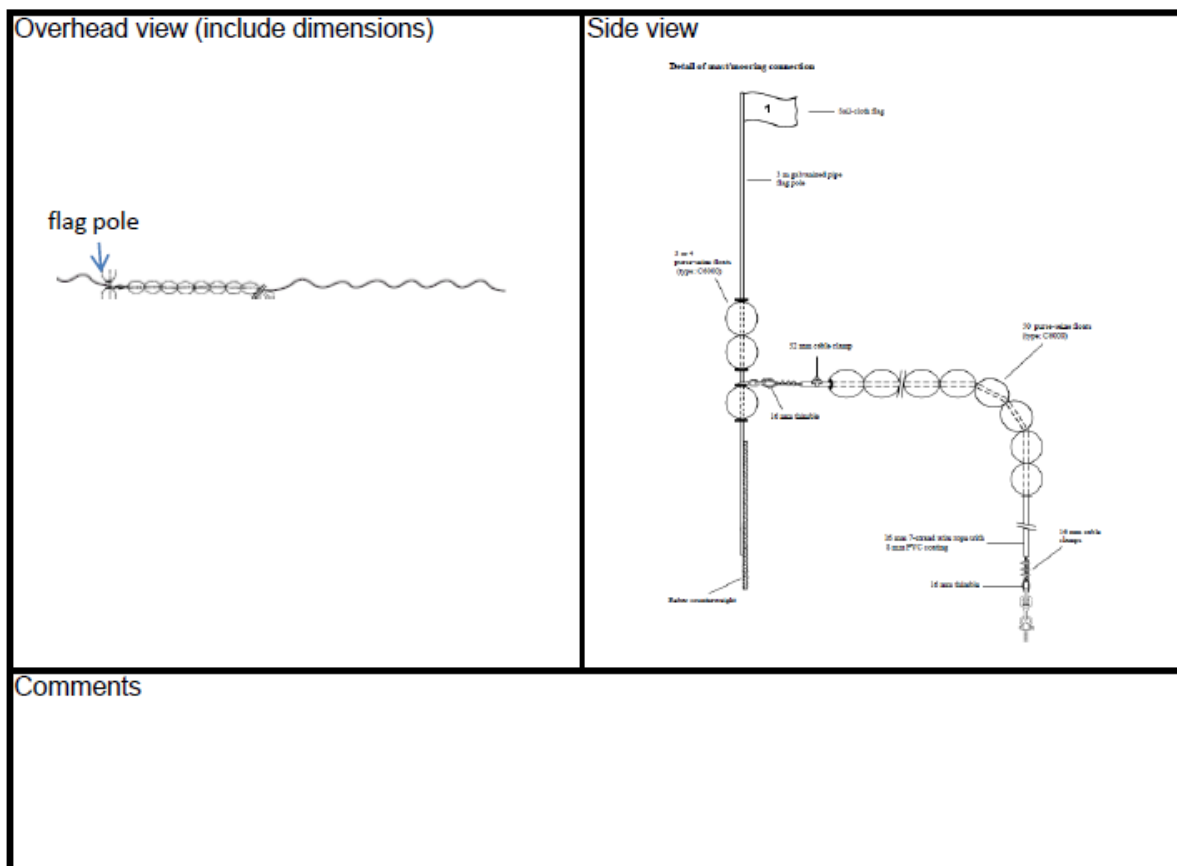

Figure 9-9 Example of floating object record.

9.6.4 Set Information & Catch Composition Form

Fill out a Set Information and Catch Composition form for all sets (including those that were not completed and sets without any catch).

Field	Definition
Observer Code:	Record your observer identification code.
Vessel Code:	Record the vessel code (Appendix 3).
Trip ID	Enter the trip identification number assigned by the SOP.
Set No.	Record set number.
Float Object / Sighting No.	If the set was associated with a floating object, record the appropriate Floating Object No. and Floating Object Sighting No. (e.g. 4 / 2).
MM Sighting No.	If set was associated with a marine mammal sighting(s), record the appropriate marine mammal sighting numbers.

Set Information

School Check one box for the primary association of the tuna school. If

Association other, use space to specify more detail.

How Detected Check one box for how the school was detected. If other, use space to record more information.

Set Sequence Times Record the times for the following:

Start set – Start set begins when net skiff is deployed into the water and begins pulling purse seine from the vessel. This should be the same as on the DAL.

Begin pursing – Record time when winches begin to bring the purse line back on board.

End pursing – Record time when all of the purse line is back on board and all rings are up.

Begin brail – Record time when the first brailer brings fish on board.

End brail – Record time when the last brail (even if this is the net) comes on board.

End set – Record time when net skiff is brought on board.

Brailer Tally As fish are brailed, tally each brailer according to its estimated fullness.

Calculate the TOTAL brailers using the following table

Tally of Full	*	1	=	A
Tally of 7/8	*	0.875	=	B
Tally of 3/4	*	0.75	=	C
Tally of 2/3	*	0.667	=	D
Tally of 1/2	*	0.5	=	E
Tally of 1/3	*	0.333	=	F
Tally of 1/4	*	0.25	=	G
Tally of 1/8	*	0.125	=	H
Total = A+B+C+D+E+F+G+H				

If you are unable to tally, leave blank and make a note in the comments section.

If fish are brailed directly onto another vessel, attempt to tally brailer fullness as well and use that brailers capacity to calculate total catch. You may not be able to take a catch composition sample if this occurs.

Total Catch (mt)

Total Catch Estimate Record the total catch estimate to nearest metric ton. This includes both retained and discarded catch brought on board. If no fish are caught (skunk set), enter 0 (zero). See next section for detailed total catch estimation methods.

Method Total Catch method options for tuna purse seine:

1. Weigh entire catch
5. Captain/Vessel estimate
8. Brailer capacity * brail tally
9. Other method used. Document method in observer logbook.

Section 9.7 explains each in more detail.

Vessel Estimate Record the captain or vessel estimate of total catch. Leave blank if one is not made.

Problems Check all problems that occurred during this set that may have affected the net's fishing ability or the catchability of tuna.

No problems – check if there were no problems.

Interaction with other vessel – check if net was fouled by another vessel.

Tide – check if the tide/current impacted the net.

Unfavorable SST

Breakdown – check if set was aborted or delayed due to a breakdown.

Tangle – check if net was tangled in any way (e.g., with a FAD or collapsed into itself due to current).

Missed mark – check if vessel missed the school it was targeting.

Other – record other problems not indicated above (e.g. fish moving too fast or move too deep).

Catch Composition

Species Name Record the common or scientific name for the species. Note that if there are multiple sample types, there may be more than one entry (row) for some species.

Code Record the 3-letter code for the species or species group (0).

ST Record the appropriate code for **Sample Type**. Codes are defined

as follows:

6A – Whole brail – all fish in the randomly selected brails are identified, counted and weighed (if possible).

6B – Partial brail – a subset of fish in the randomly selected brails are identified, counted and weighed (if possible).

1-Whole haul. If haul is small (e.g. <1 brailer), attempt to identify and count all fish.

7 – Other. Use for Marine Mammals and Sea Turtles. Leave species weight and sample weight blank.

Number	Record the total count of animals by species or species group in the sample.
Weight	<p>If no scale is available, leave this column blank.</p> <p>If a scale is available, try to weigh the fish by species or collect an average weight of each species and tally the rest. Collect 20-50 individuals per haul for average weight calculations. If you use an average weight, document your calculations in the comments/calculations box.</p>
Sample weight	<p>Record a sample weight for each sample type.</p> <p>If ST=6A, record the estimated weight of brails sampled. Calculate this sample weight using the same methods as the brailer method for estimate of total catch (code 8). Alternatively, if the vessel had a scale, sum the individual species weights to calculate the sample weight.</p> <p>If ST=6B, use actual weights or collect 20-50 individuals per haul for average weight calculations. If you use an average weight, document your calculations in the comments/calculations box.</p> <p>If ST=1, sample weight equals total catch estimate.</p> <p>If ST=7, leave sample weight blank. Make notes on appropriate marine mammal or sea turtle carcass form.</p>
Ret %	Record the percentage of each species (species group) retained by weight for sale or onboard consumption.
Reason Discard	<p>If % retained is <100, enter the most appropriate code describing the reason discard occurred.</p> <p>1 Regulation (e.g., retention of species not allowed or size</p>

- restrictions)
- 2 Market (e.g., there is currently no market to sell this species)
- 3 Damaged (e.g. fish was eaten by another species on line or in net)
- 4 Marketable but sorting error (common in shrimp trawl fishery)
- 5 Other – make notes regarding other reasons for discard

Set Information & Catch Composition - Purse Seine - Large Pelagics

Page 1 of

Observer code 175	Vessel code XYZ 388	Trip ID 00279	Set No. 2	Float.Object / Sighting No. 1 1	MM Sighting No.
-----------------------------	-------------------------------	-------------------------	---------------------	---	-----------------

Set Information			
School Association (check one)		How Detected (check one)	
<input type="checkbox"/> 1 Unassociated	<input type="checkbox"/> 4 Marine mammal	<input type="checkbox"/> 1 Vessel sighting	<input type="checkbox"/> 5 Sonar/depth sounder
<input type="checkbox"/> 2 Feeding - baitfish	<input type="checkbox"/> 5 Other:	<input type="checkbox"/> 2 Helicopter sighting	<input type="checkbox"/> 6 Info. - other vessel
<input checked="" type="checkbox"/> 3 Floating Object		<input type="checkbox"/> 3 Floating object	<input type="checkbox"/> 7 Other:
		<input checked="" type="checkbox"/> 4 Birds/bird radar	

Set Sequence Times					
Start set	Begin pursing (winch in)	End pursing (rings up)	Begin brail	End brail	End set (skiff on board)
1500	1515	1534	1538	1709	1720

Brailer tally								
Full	7/8ths	3/4th	2/3rd	Half	1/3rd	1/4th	1/8th	TOTAL
/	/ /	/ /	/ /	/ / /	/ /		/	29.375

Total Catch (mt)			Problems (check all that apply)		
Total Catch Estimate	Method	Vessel Estimate	<input checked="" type="checkbox"/> No problems	<input type="checkbox"/> Unfavourable SST	<input type="checkbox"/> Missed mark
22.03	8	20.0	<input type="checkbox"/> Interaction w/ other vessel	<input type="checkbox"/> Breakdown	<input type="checkbox"/> Other:
			<input type="checkbox"/> Tide	<input type="checkbox"/> Tangle	

Catch Composition			
Sample Type (ST)		Reason Discard	
6A Whole Brail	1 Whole haul	1 Regulation	4 Error
6B Partial Brail	7 Other	2 Market	5 Other
		3 Damage	

Species Name	Code	ST	Number	Weight	Sample Weight	% Ret.	Reason Discard
<i>yellowfin tuna</i>	YFT	6A	97	1658.7	2079.54	99	2
<i>bigeye tuna</i>	BET	↓	5	170	↓	100	
<i>skipjack</i>	SKJ		23	85.79		0	2
<i>little tunny</i>	LTA		12	91.2		0	2
<i>Blue marlin</i>	BUM		1	58.8		0	1
<i>silky shark</i>	FAL	↓	2	12.75	↓	80	2
<i>triggerfish, unid</i>	TRI	6A	1	2.3	2079.54	0	2

Comments / calculations:					
<i>Estimate 30 brailers. want to sample 3 full brails. Random number b/w 1 and 10 was 6. Sampled brail lift #6, 16 and 26. Collected all fish from brail #16 for tuna lengths and collected lengths of all non-target species from all 3 brails</i>		<i>Brail tally</i>	6	1	6
			10	0.875	8.75
			12	0.75	9
			5	0.67	3.3333
			3	0.5	1.5
			2	0.3333	0.6667
			0	0.25	0
			1	0.125	0.125
					29.375
					<i>Total catch =29.375 * .75 = 22.0313 mt</i>
Version 1.0 6/2010					

Figure 9-10 Example of Set Information & Catch Composition form for pure seine vessels.

9.7 Total Catch Estimation

There are three methods for estimating total catch on a tuna purse seine vessel and the brail tally method (#8) is the one you will use most frequently.

1. Weigh entire catch – if the vessel has a scale on the brailer, verify the weights as they are being recorded by the crew. Sum the brail weights to obtain a total weight estimate.
5. Captain/Vessel estimate – if you are unable to make an independent estimate, record the vessel estimate for total catch.
8. Brail tally – Multiply the brailer capacity (mt) by the brail tally to obtain the estimated catch weight. Round to the nearest whole metric ton.
9. Other - Document any other method used in Observer Logbook.

NOTE: Live tuna escaping from the net due to sinkage of the corkline, due to a rip in the sack or mammal release are not included in the total catch estimation. However, if this occurs, make a note in the Comments field.

9.8 Catch Composition Sampling

Sampling whole brails (ST=6A) - randomly select two or three brailers of fish per set for your catch composition sample. At first, you will need to ask the captain or crew to estimate how many brails of fish they think they've caught. With time and experience, you will be able to assess this for yourself. Ideally, you should use a systematic sampling frame with a random start point. Document your method of brailer selection in the Observer Logbook including whether or not you are sampling whole or partial brails.

For example, the crew estimates the net is holding about 30 brails of fish. In order to sample ~ 3 brails (or 10%), you would sample every 10th brail (30/3) and use the Random Number Table (Appendix 11) to determine which brail to begin with. If the random number between 1 and 10 was 4, you would sample the 4th, 14th and 24th brails to come on board. If 30 brails was an underestimate and there were really 40 in total, then you would sample the 34th brail as well.

Identify and count all fish in each selected brailer. Length sampling is prioritized by species (Table 9-1).

Weights may be determined in one of three ways:

- Actual weights – use actual weights if all fish are weighed on board. It is unlikely the vessels will have this type of equipment.
- Average weight multiplied by total count. If you can weigh 20-50 individuals of each species, use these weights to calculate an average.
- Use a length-weight table to calculate weights of fish measured. Sum the weights from the table for each species. If all fish of a given species were not all measured, use the length sample to calculate an average weight and multiply the average by the total count.

Sampling partial brails (ST=6B) - Depending on the brailer capacity, you may need to take partial brails or a ‘spill’ sample in order to sample more evenly through the haul. Selection of brailers to sample is similar to the procedure described above.

Example, the brailer holds 1,000 kg and you do not have enough space on deck to ‘hold’ an entire brail. You decide to take partial brails (one quarter of the randomly selected brails or ~250kg) for your samples. You estimate this haul is ~40 brails total and you want to sample from 8 brails. Select a random number between 1 and 5 (40/8) and pull your sample from every 5th brail thereafter. If the random number was 2, you would sample from the 2nd, 7th, 12th, 17th, 22nd, 27th, 32nd and 37th brail that was brought on board. If 40 was an underestimate, you would also sample from the 42nd and every 5th until the end.

9.9 Biological Data

Randomly select and measure individual fish each set according to the prioritized list in Table 9-1. If possible, attempt to determine sex of each individual; however, if this impacts product quality, you may record sex as unknown. Record lengths on generic length form described in Section 10.7.1.

Table 9-1 List of species for length-frequency collection on tuna purse seine vessels.

How many?	Common Name	Scientific Name
Tunas		
All	Atlantic bluefin tuna	<i>Thunnus thynnus</i>
Subsample 20-50	Bigeye tuna	<i>Thunnus obesus</i>
Subsample 20-50	Albacore tuna	<i>Thunnus alalunga</i>
Subsample 20-50	Yellowfin tuna	<i>Thunnus albacores</i>
All	Little tunny	<i>Euthynnus alletteratus</i>
All	Skipjack tuna	<i>Katsuwonus pelamis</i>
All	Frigate tuna	<i>Auxis thazard</i>
All	Bullet tuna	<i>Auxis rochi</i>
Billfish		
All	Swordfish	<i>Xiphias gladius</i>
All	Atlantic sailfish	<i>Istiophorus albicans</i>

All	Atlantic blue marlin	<i>Makaira nigricans</i>
All	Black marlin	<i>Makaira indica</i>
All	Atlantic white marlin	<i>Tetrapturus albidus</i>
All	Shortbill spearfish	<i>Tetrapturus angustirostris</i>

Other Finfish

All	Atlantic bonito	<i>Sarda sarda</i>
All	If catch <15 of any finfish	
Subsample 15-20	If catch >15 of any finfish	

Sharks

All	Bigeye thresher shark	<i>Alopias superciliosus</i>
All	Silky shark	<i>Carcharhinus falciformis</i>
All	Oceanic whitetip shark	<i>Carcharhinus longimanus</i>
All	Scalloped hammerhead	<i>Sphyrna zygaena</i>
All	Smooth hammerhead	<i>Sphyrna lewini</i>
All	Shortfin mako	<i>Isurus oxyrinchus</i>
All	Porbeagle	<i>Lamna nasus</i>

10 Biological Data & Specimen Collection

10.1 Learning objectives

- Explain how length frequency data are utilized.
- List the species to be measured for a given target fishery.
- How many and which measurements should be made?
- Determine maturity stages of fish and select invertebrates
- List the types of age structures collected

10.2 Introduction

Biological data, including sex, lengths, weights, and age structures and other specimen, may be collected on a subset of individual fish and invertebrates. This data is used by fisheries stock assessment scientists to gauge the age composition of the population, the length to age ratio, the potential spawning population, the male to female ratio and much more.

If you are assigned length frequencies, they should be collected on the primary target and a subset of other species on each sampled haul. If you are assigned length sampling, a more detailed species list will be provided at that time. The type of length measurement depends on the species being measured. Table 10-1 and Table 10-4 provide diagrams and definitions for each length type of fish and invertebrates, respectively, and summarize which measurements should be made for each species group.

Length and other measurements of marine mammals, sea turtles, and seabirds are recorded on separate forms (see Chapter 11) – do not record these groups on the Fish/Invertebrate Length Frequency Form.

10.3 List of Priorities

1. Identify and process all live marine mammals and sea turtles immediately. If a marine mammal is obviously dead, you can delay collecting data on it until after you complete #2-3.
2. Randomly collect, determine gender and measure a subsample of the primary target species from each sampled haul. The quantity of measurements depends on the target fishery.
3. Randomly collect, determine gender and measure a subsample from a minimum of 5 additional species from each sampled haul.
4. Complete a species identification form for each new species encountered.
5. Identify and enumerate all seabirds caught; seabirds have a separate form.

10.4 Length Measurements

Length measurements will be **rounded down** to the nearest whole centimeter (fish) or millimeter (invertebrates). For instance, if you have three fish lengths of 44.2, 44.5 and 44.8 cm, all are recorded as 44 cm – see also Figure 10-1. Do not measure damaged individuals (e.g., missing tail or rostrum). However, these individuals should be recorded with a length of “0”.

The snout should be resting gently against the head piece of the measuring board or other vertical surface (e.g. a bulkhead). Always be sure to keep your eye directly above the tail of the fish to ensure the correct measurement is recorded. If the measurement is taken when your eye is not directly above the tail of the fish, the measurement will be read at an angle, possibly giving an incorrect result.

When an individual is larger than the measuring device provided, measure it by taking two or more measurements. One method is to first measure as much of the fish as possible, make a light mark on the fish at the point where the measurement stops, and then take a second measurement from that point. Adding the two measurements together gives the length of the fish. Another method is to take the first measurement at 100 cm, lightly mark the fish at this point, and then take a second measurement from the point. It is then easy to add the two measurements together to get the full length.

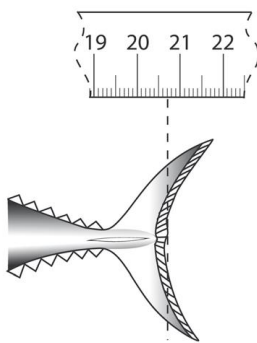

Figure 10-1 The fork length of this fish would be recorded as 20cm whereas the total length would be 21cm. Image from Brogan et al. (2006)

10.4.1 Fish (bony & cartilaginous)

10.4.1.1 Standard measurements

The most common measurement used for fish is fork length although there are many other length types. Table 10-1 contains definitions for the various measurement types and lists the typical groups for each measurement type.

Table 10-1 Standard measurements for bony and cartilaginous fish. Images and definition from (Anderson and Gutreuter 1983, Kranz 2007, Southeast Fisheries Science Center 2007, NMFS 2008a).

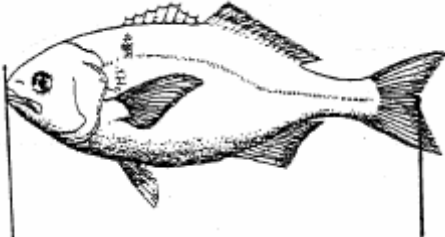
Measurement name-abbreviation (length code)	Measured from (typical species)	Figure
Fork length-FL (01)	Snout tip to center of fork in caudal fin (straight). Mouth should be closed (Fish; Sharks). Typically taken on species with concave (forked) tails.	

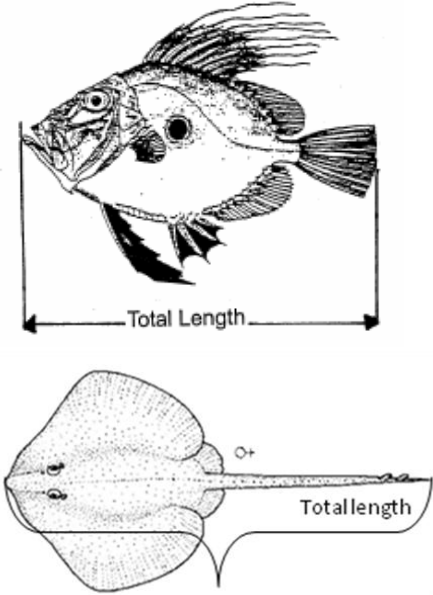
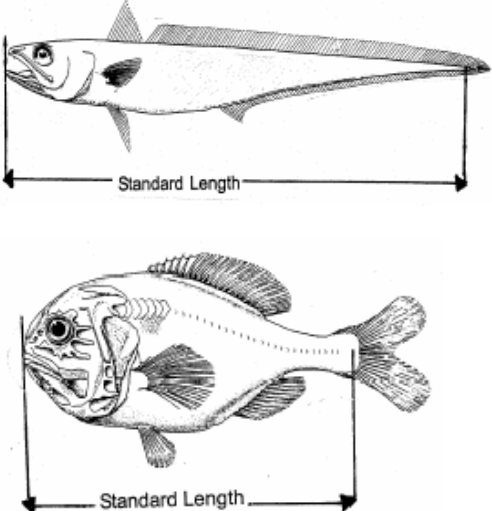
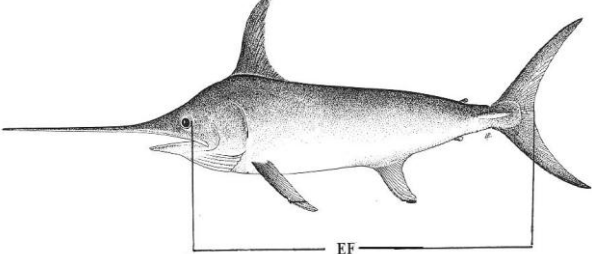
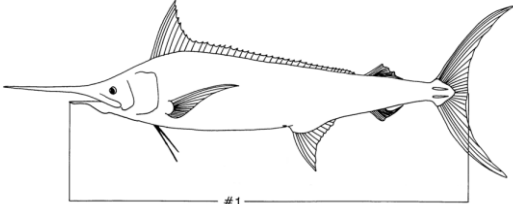
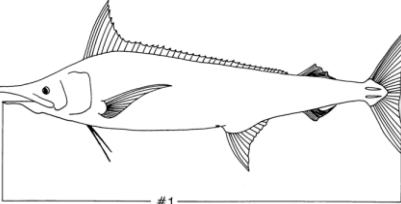
<p>Total length-TL (02)</p>	<p>Snout tip to furthest tip of tail (Fish; Skates/rays). Typically taken on species with convex tails. Tail should not be compressed to spread to its extreme when measured.</p>	
<p>Standard length-SL (03)</p>	<p>Snout tip to last caudal vertebrae (usually marked by a shallow vertical groove near the extremity of the fleshy part of the tail).</p>	
<p>Eye to fork length (04)</p>	<p>Straight-line measurement from the posterior margin of eye orbit to the fork in tail. (Billfish)</p>	
<p>Lower jaw to fork length-LFL (05)</p>	<p>Curved length from tip of lower jaw to caudal fork length (Billfish; swordfish)</p>	
<p>Cleithrum to fork (06)</p>	<p>Straight-line measurement from the inside leading edge of the cleithrum to the fork in tail. The cleithrum is the bony structure which anchors the</p>	

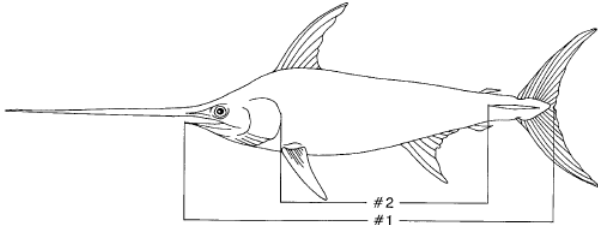
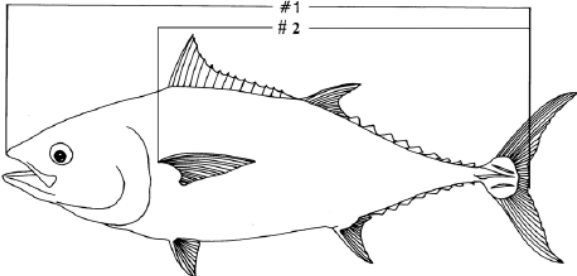
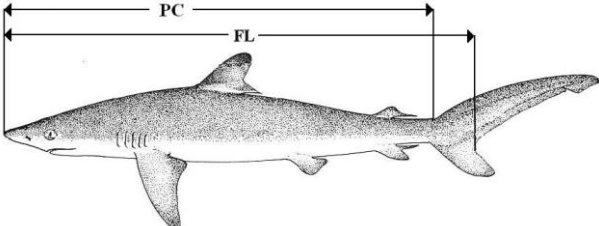
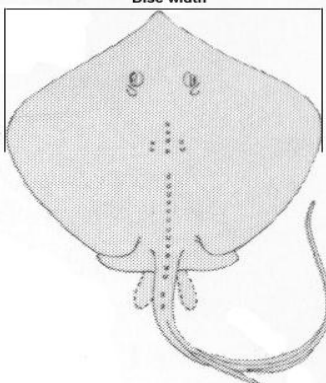
	pectoral girdle. It is the bony anterior margin of the body after head removal, and is light in color and slightly concave. Measurement sometimes used if measured collected after dressing (swordfish).	
Cleithrum to caudal keel (07)	Cleithral arch to caudal anterior origin of caudal keel. This is a curved length (swordfish-#2 in figure)	
Pre-anal fin length-PAFL (08)	Measured from the tip of the snout to the insertion of the first anal fin ray, immediately posterior to the anus (Grenadier). Taken on fish that commonly have damaged caudal fins or tails.	
Pectoral fin to fork (09)	Anterior insertion of pectoral fin to fork of tail (straight; tunas #2 in figure)	
Pre-caudal length-PC (10)	Snout tip to the pre-caudal pit (small crease) at the end of the caudal peduncle. If the shark does not have a pre-caudal pit, use the point where the front edge of the upper tail lobe meets the caudal peduncle. (2 nd shark measurement)	
Disc width (11)	Distance between the furthest opposite points of the wings (skates, rays)	

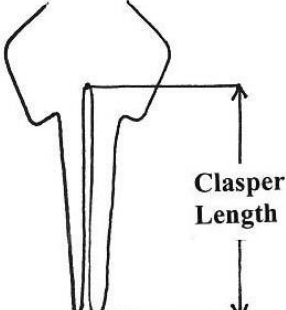
Clasper inner length (12)	Tip of the clasper to the center of the angle between the claspers. (3 rd shark, 2 nd skate measurement)	
---------------------------	--	---

10.4.1.2 Sex determination

Because males and females of certain species grow at different rates, fisheries biologists are especially interested in having length frequencies separated by sex so they can better monitor such growth patterns (Van Helvoort 1986). Sex can be determined using either external or internal characteristics.

10.4.1.2.1 External differentiation

A few species (mostly the cartilaginous fishes) can be sexed based on external features. Male sharks, skates and rays have external claspers emerging from their pelvic fins (Figure 10-2). Opah and dolphinfish are also sexually dimorphic (Figure 10-3 and Figure 10-4, respectively)

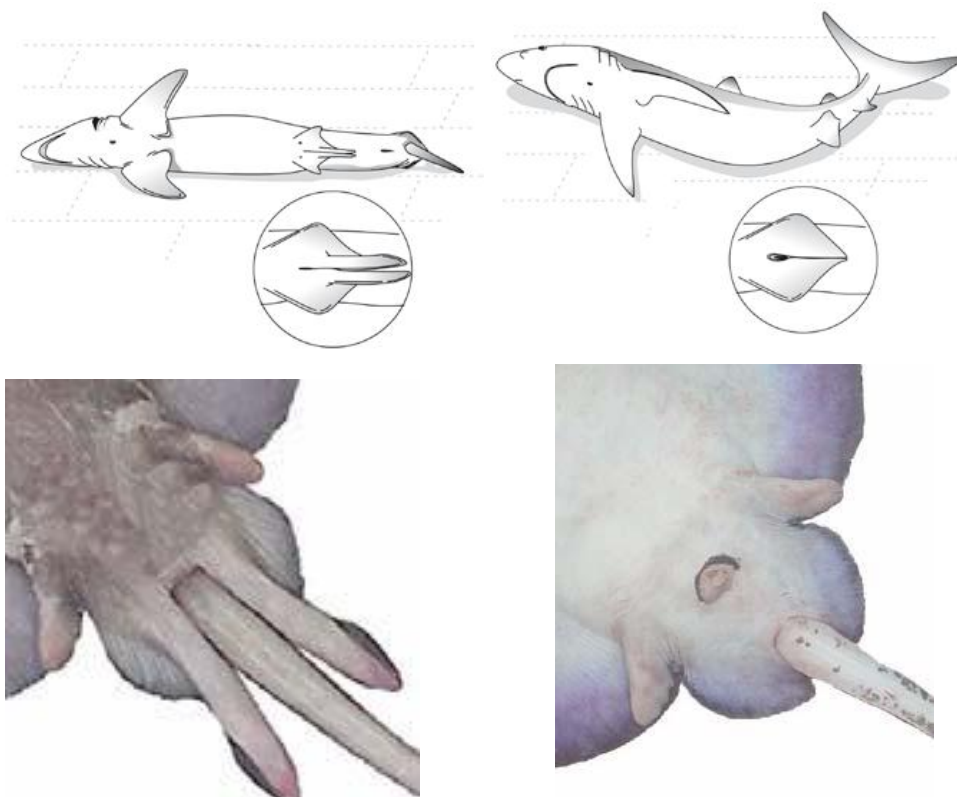

Figure 10-2 Male sharks and other elasmobranchs have claspers (left) emerging from the ventral section of their pelvic fins whereas females do not have this feature (right). Images from Brogan et al. (2006) and Alaska Fisheries Science Center (2009).



Figure 10-3 Male opah (*Lampris guttatus*; left) have distinct double edged (concave) breastplate that is somewhat sharp and angular whereas the female opah (right) chestplate is convex with a more gentle slope. Image credit: D. Itano in McAuliffe et al. (2007).

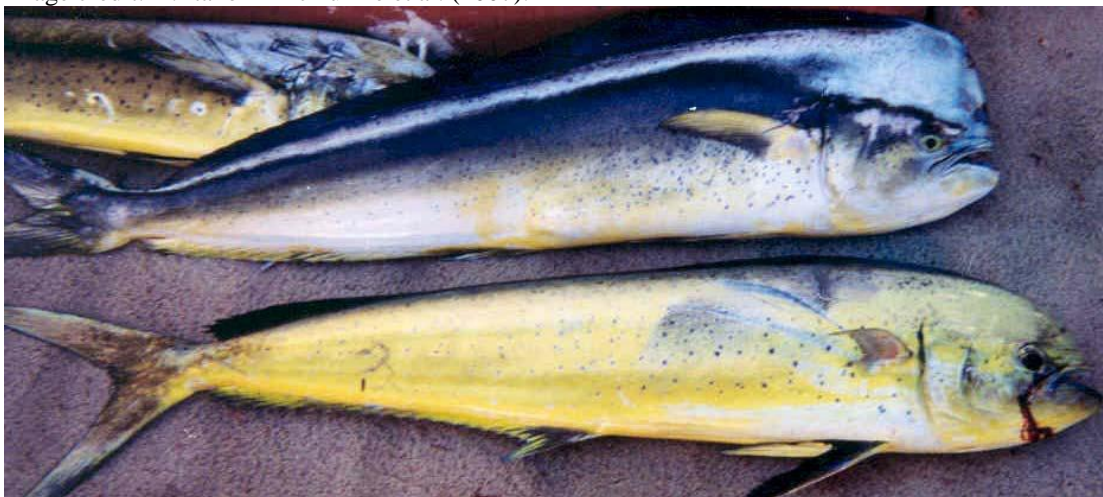



Figure 10-4 The male dolphinfish (*Coryphaena hippurus*; top) has a pronounced bony crest on its 'forehead' whereas the female (bottom) forehead slopes gently. Image from NMFS (2008a).

10.4.1.2.2 Internal differentiation

Most bony fish lack external sex differentiation features and must be cut open to evaluate internal organs. Gonads are typically located in the posterior portion of the cut cavity near the back bone. The easiest way to access the gonads is to slit the belly 4-8cm parallel to the spine

and slightly ahead of the anal opening (vent). You may need to reach in to move the intestines and/or fatty tissue aside. Each group of species is slightly different but in general, males have solid gonads that may be smooth or highly crenulated whereas female ovaries are paired sacs. Immature male gonads are frequently string-like. If asked to collect sexed length-frequencies, you will have additional training specific to the species/fishery although Table 10-2 includes a few species groups that you are likely to encounter. If the product is whole fish, you may also need to negotiate with the captain to cut open a few fish for the length sample.

Table 10-2 Summary of sex differentiation for common species groups. Compiled from (AFSC 1997, Brogan et al. 2006, NMFS 2007b).

Male	Female
TUNAS <i>Euthynnus</i> , <i>Thunnus</i> sp.	
The testes are usually elongated and uniform in shape throughout. They are flatter and thinner when compared to the swordfish testes. Generally, there is more fatty or connective tissue associated with the tuna testes than with the swordfish testes.	Same characteristics as swordfish ovaries.
SWORDFISH <i>Xiphias gladius</i>	
<p>The most prominent characteristics of male swordfish gonads are:</p> <ul style="list-style-type: none"> • triangular in shape (cross section) & smooth exterior • in cross section, contains a small opening (lumen) with smooth edges • no granules visible <p>Color: white to pink</p> 	<p>The most prominent characteristics of female swordfish gonads are:</p> <ul style="list-style-type: none"> • oval/circular shape (cigar or sausage shaped) • rough (striated) external appearance • in a cross section, the presence of a lumen (opening) near the center with somewhat rough edges • small granules (eggs) frequently present <p>Color: variable, ranges from gray (indicating immature egg production) to orange (indicating near spawning). Generally, swordfish and tuna over 250 pounds are female.</p> 

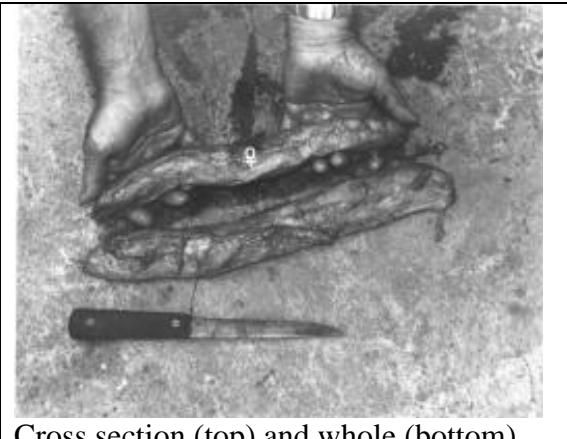
	
<p>Cross section (left) and whole (right) views of male swordfish gonads. Courtesy of U.S. National Marine Fisheries Service, Southeast Fisheries Science Center.</p>	<p>Cross section (top) and whole (bottom) views of female swordfish gonads. Courtesy of U.S. National Marine Fisheries Service, Southeast Fisheries Science Center.</p>
<p>Flatfish: The gonads of flatfish are found posterior to the visceral cavity and may extend underneath the flesh of the body (esp. females). To find the gonads it is usually easiest to cut backward from the vent on the blind side following the curvature of the gut cavity (NPGOP)</p>	
<p>The testis is tapered at the anterior edge, is triangular in shape, and does not extend as far back as the ovary. It extends back toward the caudal fin about twice the distance of the width of the front edge. Depending on maturity stage, the testis will appear clear and transparent (immature) to opaque and white (ripe) in color.</p>	<p>The anterior edge of the ovary is rounded, and extends back toward the caudal fin, forming a balloon or sac-like structure. In mature fish the ovary extends back to a minimum of one half of the body cavity. Depending on maturity stage, the ovaries will appear light pink (immature) to bright orange (ripe) in color.</p>

10.4.1.2.3 Sex codes

There are four codes recorded for sex (M, F, I and U) defined as follows:

- M Record for all fish determined to be **male**.
- F Record for all fish determined to be **female**.
- I **Indeterminate.** If the gonad is checked but is too immature to determine the sex, the observer should record I. Both immature male and female gonads are likely to be string-like and thin and some of the features outlined above may not be obvious when the gonad is examined.
- U **Unknown.** Use this code when you were unable to check the sex due to lack of time or damage to product.

10.4.1.3 Maturity

In general, maturity stage is grouped into several stages for each gender. You will be provided with additional training if asked to determine maturity.

10.4.1.4 Age structures

Certain structures, or parts, of fish can be used to determine age. These are used to study a fish population by estimating the age composition of fish that are caught from an age-length relationship. **If you are instructed to collect age structures, you will be provided with additional training.** Age structure data is recorded on the Specimen Collection Form.

10.4.1.4.1 Scales

Scales are small, thin, overlapping structures protecting the skin of fish. Scales produce annual rings (similar to trees) that can be used to estimate a fish's age. The following steps outline the scale collection procedure for most fish:

1. Rinse the fish with water and rub the body lightly from head to tail. This removes loose scales and mucus that may be from another fish.
2. Choose scales from immediately above or below the lateral line (Figure 10-5). Note: depending on the species, you may be provided with alternate locations.
3. Use forceps to loosen and remove a few scales. You will feel a slight resistance if the scale is embedded in the sample fish
4. If possible, clean by dipping in water and rub them between your fingers.
5. Place in envelope and label appropriately.

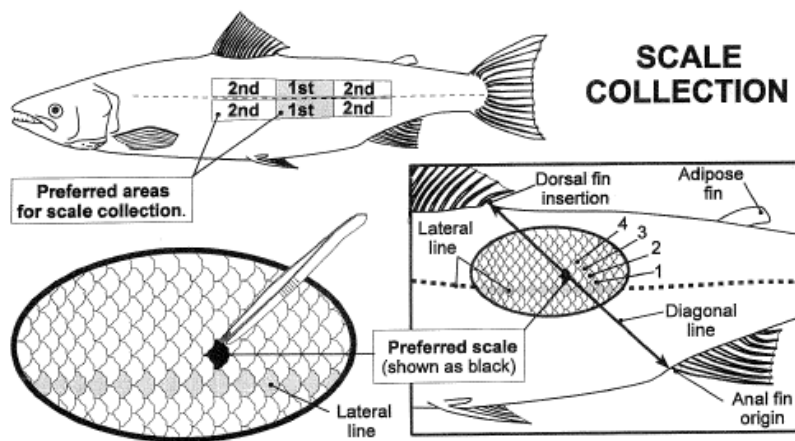

Figure 10-5 Scale collection areas. Image from Hanrahan et al.(1997).

10.4.1.4.2 Spines/Rays

Fins are composed of a membrane and rays (and/or spines). The rays have growth rings that can be used to age some species. Collecting a fin ray sample involves cutting the fin away from the body and storing in an appropriately labeled envelope or scintillation vial.

10.4.1.4.3 Otoliths

Otoliths are small, bony structures made of calcium carbonate. There are three pairs of uniquely sized and shaped otoliths for most species although only the largest pair (saggita) is

typically collected for aging purposes. They are located in the otic cavity of the inner ear of bony fishes and aid in positioning the fish relative to gravity and in sound detection. Otoliths grow in size with the fish and display their growth in annual rings, or annuli. In flatfish, because the head is twisted during early development, the otoliths are positioned one on top the other directly behind the brain whereas in roundfish, they are positioned side-by-side.

Methods of extraction vary by species. The otic cavity can be accessed from the top of the head with a perpendicular or a parallel cut as well as from below (Figure 10-6 and Table 10-3). Carefully remove the otoliths with forceps. Clean/dry the otolith by rubbing it gently between the thumb and forefinger. Otoliths may be placed in envelopes or scintillation vials.

If otoliths are stored in envelopes, they should be labeled with the following information: observers code, vessel code, trip number, haul, date, species code, specimen number, length, weight, and sex. In addition, otoliths stored in envelopes should be stored carefully to prevent unnecessary damage (otoliths are very brittle).

If otoliths are stored in vials, be sure to add appropriate solution (e.g., glycerine) for storage.

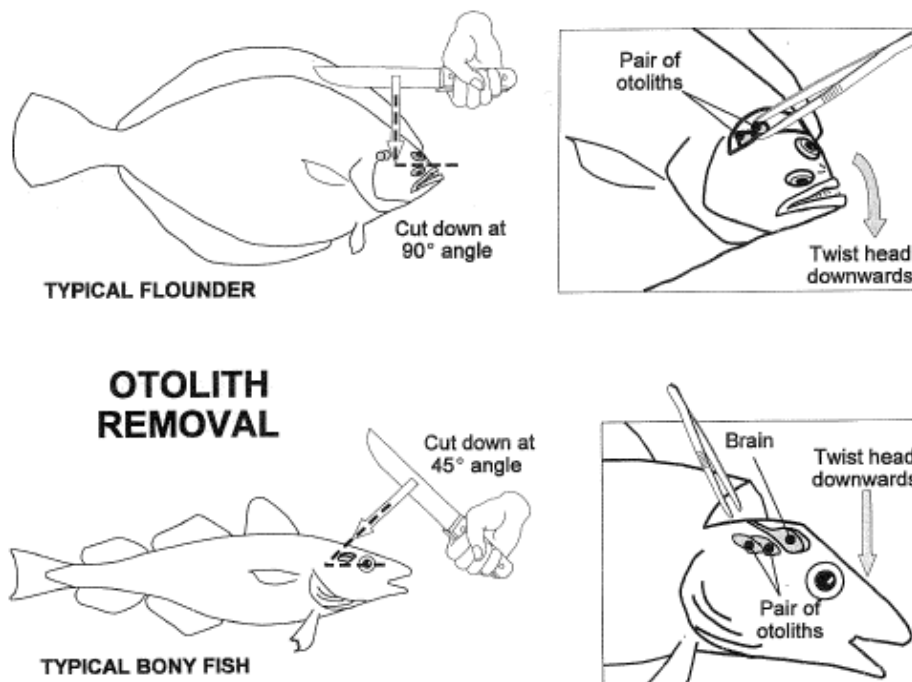

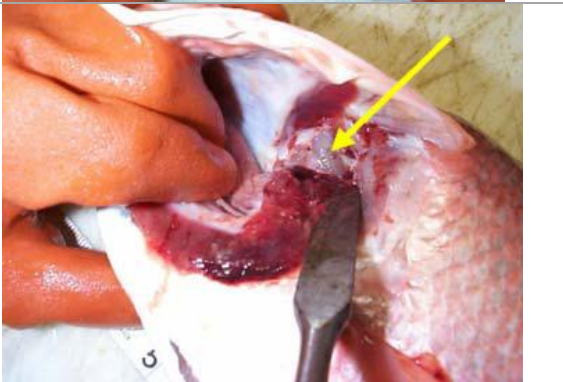



Figure 10-6 Otolith position and removal for flat (upper) and round (lower) fish. Image from Hanrahan et al. (1997). Some roundfish otoliths are more easily accessed with the 90° cut.

Table 10-3 Steps for removing otolith from below otic cavity. Photos and protocol extracted from (NOAA Fisheries Service 2009).

<p>1. Lift opercle and expose gill.</p>	
---	--

<p>2. Cut away the gill arches at their insertion.</p>	
<p>3. Use a chisel to scrape away tissue from the otolith capsule, the capsule will feel like a large knob or protrusion</p>	
<p>4. Open the capsule with a chisel, the large sagittal otoliths can be easily removed with forceps.</p>	

10.4.1.4.4 Thorns and Vertebrae

Thorns may be collected to age skates/rays and vertebrae can be used to age skates/rays, sharks and some fish.

10.4.1.5 Food habits

Stomach scans or stomach collection may be added to observer protocols at a later date.

10.4.2 Invertebrates

10.4.2.1 Standard measurements

The most common measurement used for shrimp is total length and for crab is carapace width although there are many other measurement options. Table 10-4 contains definitions for the various measurement types and lists the typical groups for each measurement type.

Table 10-4 Standard measurements for various invertebrates. Images and definition from (Mauchline 1980, ACCSP 2004, CCAMLR 2006, NMFS 2007a)

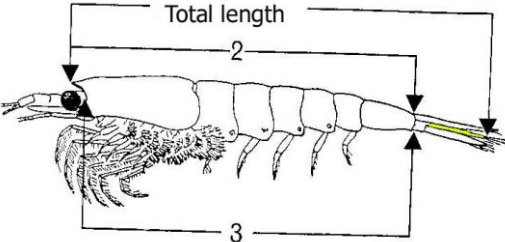
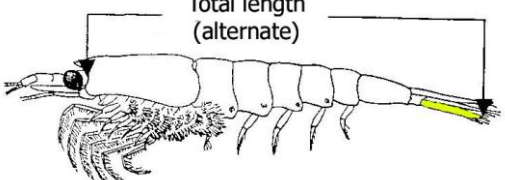
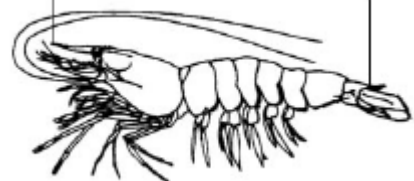
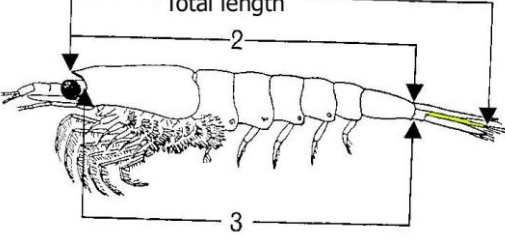
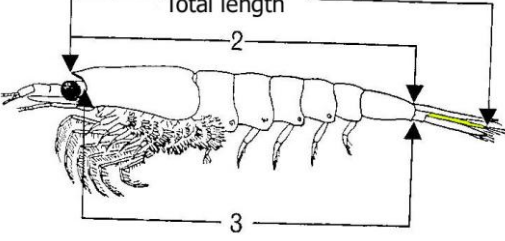
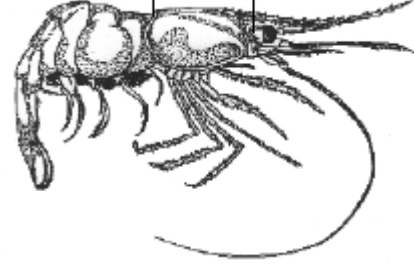
Measurement	Measurement description (typical species)	Figure
Total length (02)	Tip of rostrum to posterior tip of uropods (excluding terminal setae). Uropod shaded yellow. (Preferred length for shrimps)	
Total length – alternate (30)	Distance between the base of the eye-stalk to posterior tip of uropods (excluding terminal setae). Uropod shaded yellow.	
Total length – alternate (31)	Tip of rostrum to tip of telson	 <p data-bbox="783 1025 1262 1077">ACCSP - Atlantic Coastal Cooperative Statistics Program</p>
Body length (32)	Tip of rostrum to posterior margin of last abdominal segment (#2 in image). Uropod shaded yellow.	
Body length (33)	Distance between the base of the eye-stalk to posterior margin of last abdominal segment (#3 in image)	
Carapace length (34)	Distance along the dorsal surface of the carapace from the rear margin of the eye to the back edge of the carapace. See also #5 in next image. (prawns, preferred length for lobsters)	

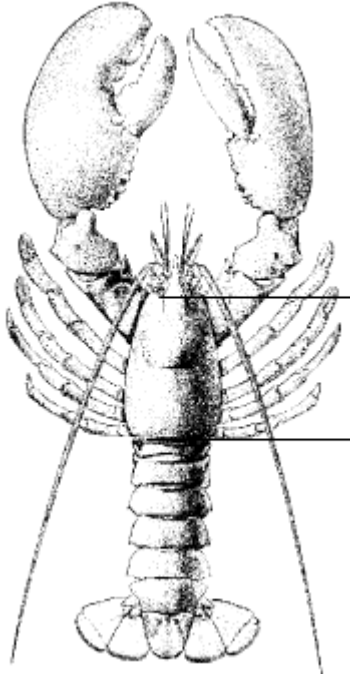
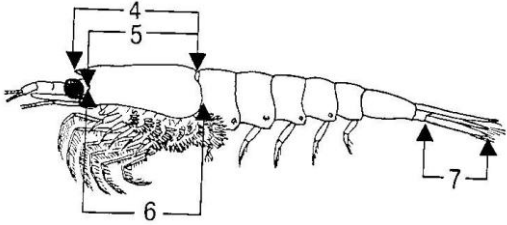
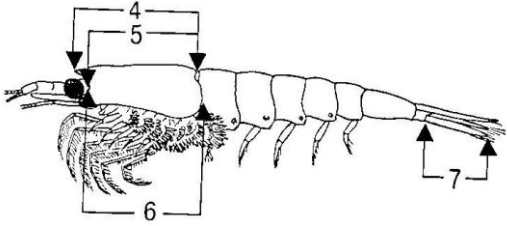
		
<p>Carapace length (35)</p>	<p>Dorsal distance between the anterior tip of the rostrum and the mid-dorsal posterior edge of the carapace (#4 in image)</p>	
<p>Carapace length (36)</p>	<p>Distance between the base of the eye-stalk and the posterior lateral edge of the carapace (#6 in image)</p>	

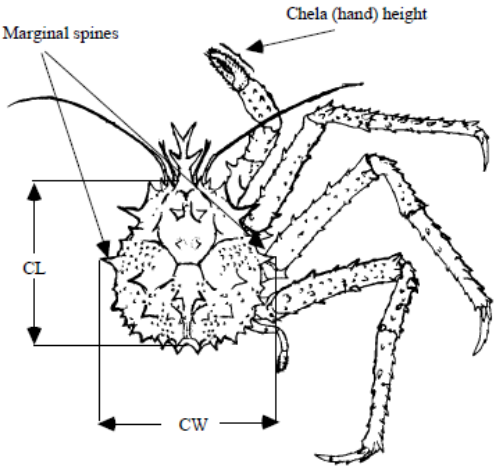
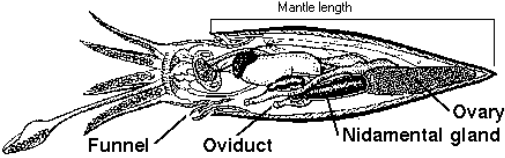
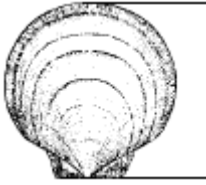
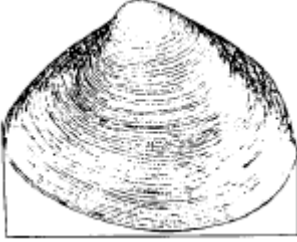
Carapace length (37)	Posterior edge of the eye socket to median posterior carapace (crab)	
Carapace width (38)	Largest width across the carapace including marginal spines (crab)	
Mantle length (45)	Straight line measurement from the tip of the fin to the base of mantle (squid)	
Shell height (46)	Distance from hinge to bill edge (scallops)	
Shell width (47)	(clams)	

10.4.2.2 Sex determination

Sex determination of the invertebrates varies by group.

10.4.2.2.1 *Shrimp*

On the first pair of swimming legs (pleopods), male endopods are notched whereas female endopods are pointed (Figure 10-7). You will not need to separate shrimp by sex unless specifically assigned a special project.

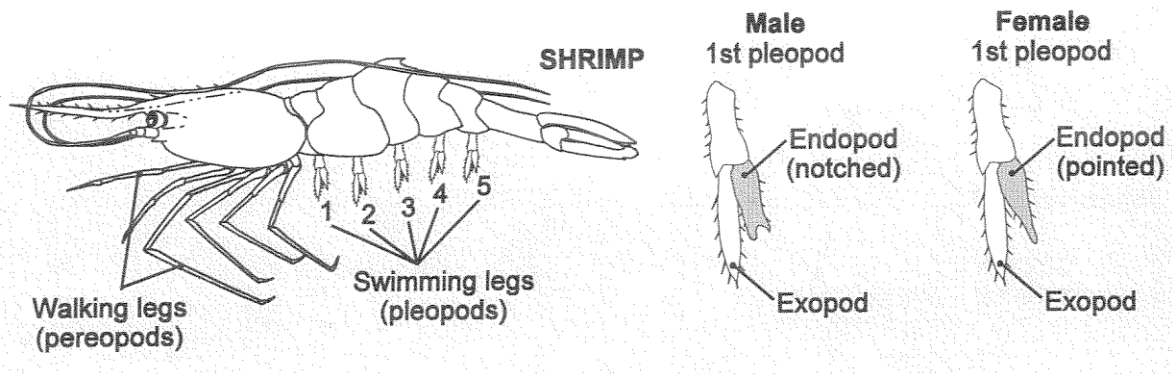

Figure 10-7 Sex differences in shrimp. Image from Hanrahan et al.(1997).

10.4.2.2.2 Crab

For crab, the main difference between the sexes is the shape of the abdominal flap. Females tend to have larger, rounder flaps whereas males are smaller and more triangular in shape (Figure 10-8).

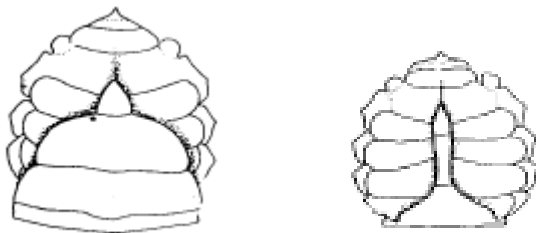

Figure 10-8 Sex differences in crab. Image from (NMFS 2007a)

10.4.2.2.3 Lobster

The primary difference between male and female lobsters is the size of the first pair of swimmerets: females are thin and filament-like whereas males are thick in shape and firm in texture (Figure 10-9). Females also have a relatively large genital opening between the third pair of walking legs whereas males have a small genital opening on the fifth pair of walking legs.

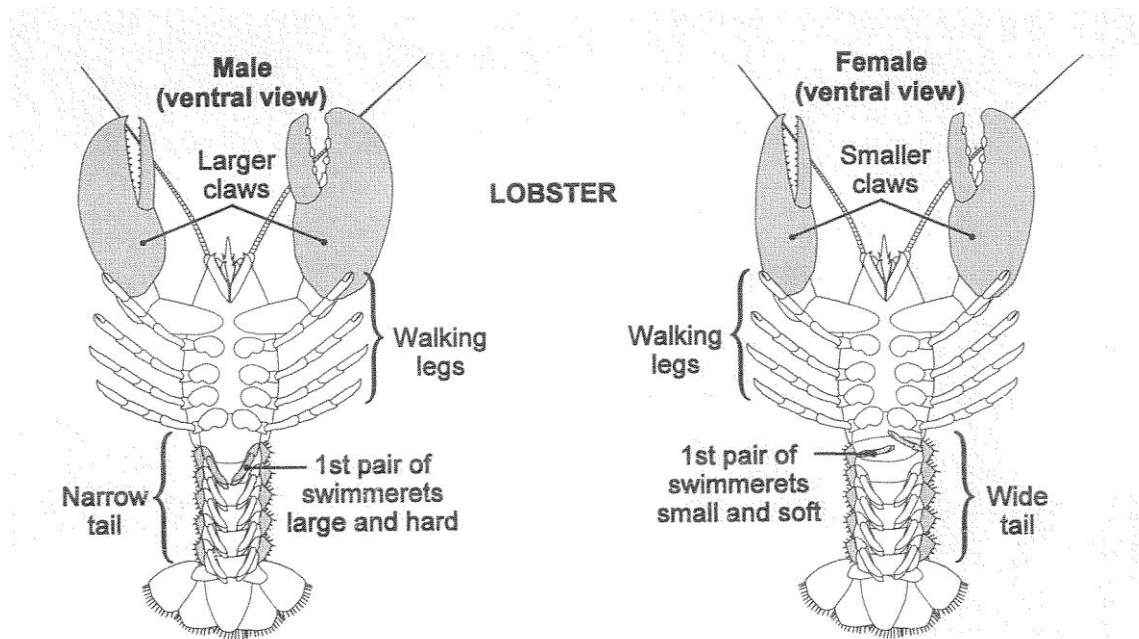

Figure 10-9 Sex differences in lobster. Image from Hanrahan et al. (1997).

10.4.2.3 Crab and Lobster Maturity

For male crab and lobster, leave maturity blank. For female crab and lobster, maturity definitions are as follows:

- 1-no eggs visible
- 2-eggs visible (no eyes)
- 3-eggs visible (eyes visible)
- 4-eggs visible (eyes unknown)

Crab and lobster bearing eggs are also called “gravid” or “berried”.

10.5 Additional Collections

10.5.1 Collection of whole fish / invertebrates

Whole animals may be collected at the request of the SOP. You may be asked to collect unidentifiable species or rare species as well. When it’s not feasible to return specimen to shore, attempt to take a photograph and document distinguishing features by completing a species identification form. Complete a Specimen Collection form for all collected specimen.

Collected specimen must be preserved in some way. There are four primary preservation methods: salt, ice, freezing or chemicals.

- Salt: Insert salt into the gill chamber and body cavity. The whole body can then be rolled in salt and placed in a waterproof plastic bag or container. This method is meant for short term preservation.
- Ice & Freezing: Place specimen and a specimen label in a waterproof bag or container. Store on ice or in freezer hold and transfer to the SOP immediately upon debarkation.
- Chemicals: Not applicable to scientific observers at this time.

Insert a specimen collection tag with each specimen collected. At a minimum, this tag should include the specimen number, your observer code, vessel code, date, haul number, and species name/code. It is also useful to include the sex, length and weight.

10.5.2 Tagged Animals

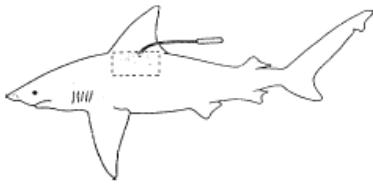

Fish and other marine animals are tagged to obtain information about their movements, migrations, stock structure, growth, population size, mortality, schooling behavior, and physiology and to investigate the effects of various patterns of fishing on the fish and the fisheries.

There is an assortment of tag types but they can be grouped into two categories: conventional and electronic. Conventional tags (streamers or spaghetti tags, dart or discs/buttons) are attached externally. The tags have a serial number and an address for returning the tag if found on a fish (Figure 10-10).

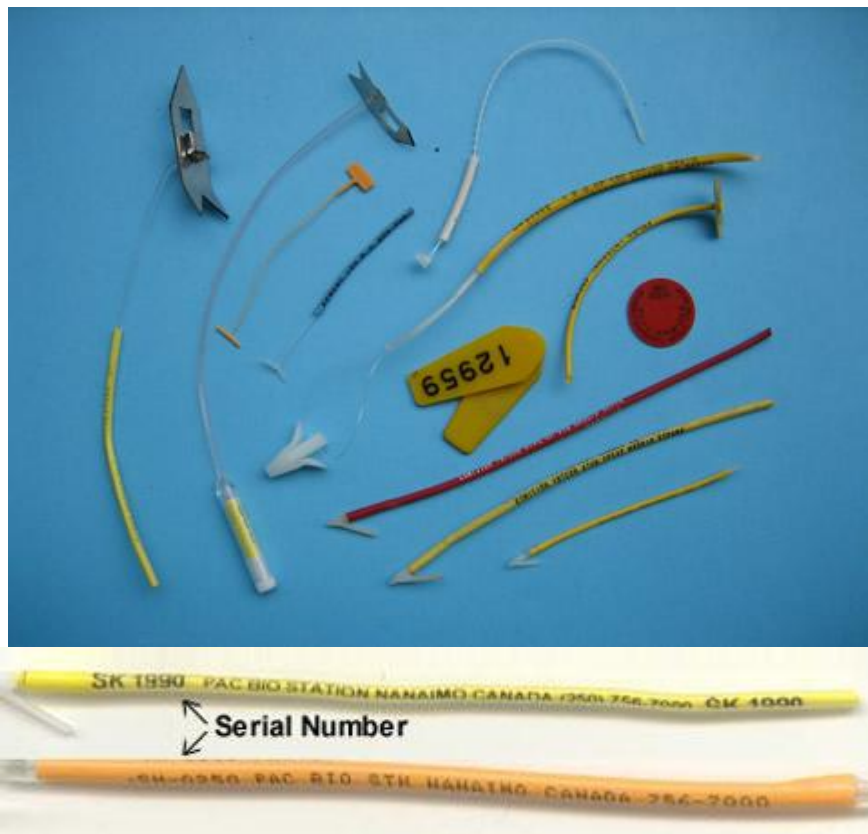

Figure 10-10 Conventional tags (top) and close-up of spaghetti tag (bottom). Images from ICCAT and Pacific Biological Station, Department of Fisheries and Oceans, Canada.

Electronic tags, while more expensive, can provide more detailed information. Animals with electronic tags are also marked externally with a conventional tag (e.g., if electronic tag is implanted) or with the electronic tag itself. Examples of electronic tags include:

- Archival tags - implanted internally and can measure pressure (for depth of dives), ambient light (to estimate location), internal and external body temperature, and, in

some cases, speed of travel. A green or green and white conventional tag typically indicates the presence of an archival tag.

- Acoustic tags - small sound-emitting devices that allow the detection and/or remote tracking of fish in three dimensions.
- Pop-up tags - attached externally. After a pre-determined time, they detach from the fish, float to the surface and transmit information via satellite.

Tags can be attached nearly anywhere although the muscle below the dorsal fin and behind the pectoral fin are common tag locations for fish.

What to do if you encounter a tagged animal?

Fill out the Tag Encounter and Recovery form for each tag you encounter from all fish or invertebrates. Tag information from marine mammals, sea turtles and seabirds should be recorded on the appropriate carcass form. If a tagged fish is dead or will be retained, collect the tag, length, weight, sex and aging structures. If the animal is alive and will be released, leave the tag on the fish, measure (or estimate) length and carefully release as quickly as possible.



Tag Rewards

There are many entities deploying tags in the Atlantic Ocean. Each program employs different methods for rewarding tag recovery. More information regarding tuna and billfish can be found in Figure 10-11 and <http://www.iccat.int/en/Tag-Program.htm>.

REWARD

for the recapture of a tagged fish





If you find a tagged fish don't pull out the tag until the specimen is measured or weighed. If you can save the fish for examination, do so.

The following information needs to be reported (as detailed as possible):
Tag code (letters and numbers), colour and address printed in the tag
Species, sex (if possible) and length or weight (specify type & units of measurements)
Date and place where the fish was caught and the fishing gear used

Please provide any additional information, such as water temperature, fish condition, wounds, etc.







> Tags implanted on fish are used to learn about fish behaviour and migrations and to estimate important population parameters, such as abundance, mortality and growth. There are three main types of tags: (1) Conventional, (2) Pop-up Satellite Archival, and (3) Internal Archival.

> Pop-up Satellite Archival Tags are electronic data-logging devices that provide location estimates, swimming depth and water temperature. This information is collected and stored in the tag's memory. A summary of these data is then transmitted to the Argos satellite system after the tag pops off at a predetermined time. Pop-up tags are valuable even when found on a beach years later because their memory still maintains the data accurately.

> Internal Archival Tags are implanted in the abdomen of the fish and only the sensor can be seen protruding from the belly. These are electronic data-logging devices that provide the same information as pop-up tags, as well as the fish body temperature. This information is stored in the tag until the fish is recovered. **Please avoid pulling the sensor when removing the tag from the fish.** To remove the tag make an incision on the fish's belly.

Acoustic tags are also electronic tags placed inside the body cavity and are not visible from the outside.

To claim your reward please contact or send information together with the tag and your address to:
ICCAT, E-mail: info@iccat.int, Address: C.P. 542, Madrid, Spain

Closest Local Fishing Agency **Recovery form available in www.iccat.int**



INTERNATIONAL COMMISSION FOR THE CONSERVATION OF ATLANTIC TUNAS

Figure 10-11 ICCAT tag reward poster.

10.6 Species Identification

More than 500 species of fish and invertebrates occur in the Gulf of Guinea and Eastern Atlantic Ocean. In each sample, the primary commercial species should be identified to the species level as well as marine mammals and sea turtles. Other species can be identified to the family or even phylum level (Table 10-5)

Table 10-5 Generic guide to levels of species identification.

Genus / Species	Family	Phylum / Class / Order
-----------------	--------	------------------------

-
- | | | |
|---|---|---|
| <ul style="list-style-type: none"> • Marine mammals • Sea turtles • Sharks & rays • Bony fish: Tunas & tuna-like fishes, see also country specific list in Appendix 1 • Shrimp: <i>Penaeus notialis</i>, <i>Penaeus kerathurus</i>, <i>Parapenaeopsis atlantica</i>, <i>Parapenaeus longirostris</i> • Crab: <i>Callinectes amnicola</i>, <i>C. pallidulus</i>, <i>Portinus validus</i>, <i>Callapa robroguttata</i> • Lobsters: <i>Panulirus regius</i>, <i>P. argus</i> • Cuttlefish, octopus and squids: <i>Sepia officinalis hieredda</i>, <i>Sepia bertheloti</i>, <i>Octopus vulgaris</i>, <i>Illex coindettii</i>, <i>Alloteutis africana</i>, <i>Loligo vulgari</i> | <ul style="list-style-type: none"> • Seabirds • Fish: all except those listed in Species column and country specific list | <p>Phyla</p> <ul style="list-style-type: none"> • Porifera –sponges; <p>Classes</p> <ul style="list-style-type: none"> • Scyphozoa – jellyfish • Polycheata • Gastropoda – snails, limpets, nudibranchs • Pycnogonida – sea spiders • Crinoidea – feather stars • Stelleroidea – starfishes • Echinoidea – sea urchins, sand dollars • Holothuroidea – sea cucumbers <p>Order</p> <ul style="list-style-type: none"> • Actinaria – sea anemones • Scleractinia – corals • Pennatula & Gorgonacea – sea pens, sea whips, sea fans |
|---|---|---|

Species identification forms allow the SOP to verify that the identification of species seen during a deployment is correct. ***Species identification forms are required for all fish, invertebrates and dead seabird species that are new to you.*** There are separate forms for marine mammals and sea turtles. The first trip in a new target fishery or area may require several of these forms to be completed.

During debriefing, you may be asked to provide a verbal description of a fish if you don't have an ID form, or if it is incomplete. If you are not able to provide an accurate description of a species recorded in your samples, the SOP may change the data to a higher taxonomic grouping and you may need to take another fish ID test in the future. It is advisable to complete multiple ID forms on species that you do not encounter frequently, so that you have a written record to refer to.

Unidentified Fish

Never guess the identification of a species. If you encounter an individual animal that you cannot identify, fill out a species description form with as much information as possible. You may find a more identifiable specimen of the same species later, so organize your unidentified fish descriptions with names such as “unidentified shrimp #1,” or “unid fish #5.” Record all form heading information, so that the data can be changed if the fish is identified later. ***Ideally, you should bring the specimen back to the SOP.*** If you are unable to bring the fish back, attempt to take photographs of the specimen for identification purposes.

Record unidentified fish on your Catch Composition form with the most appropriate group code. For example, an “unidentified Penaeid shrimp” should be recorded using the “Penaeid shrimp unidentified” group code of PEZ.

Standard Species Identification Guides

Observers will be provided with some guides for quick reference and guides that are more comprehensive. An important species identification guide for West African Atlantic Region is the FAO Species identification sheets for fishery purposes ((Schneider 1990) shown below)



FIELD GUIDE TO THE COMMERCIAL MARINE RESOURCES OF THE GULF OF GUINEA



It is mandatory that all Observers carry with them fish identification guides. On your species identification forms, record scientific names to minimize confusion. Common names for a fish are highly variable among fishermen and sometimes the same common name is used for entirely different fish. It is advisable however that all Observers commit to memory and be able to identify most of their common species, as there will be no time onboard to follow long identification keys.

10.7 Fish and Invertebrate Forms/Instructions

10.7.1 Fish / Invertebrate Length Frequencies

Complete the Fish/Invertebrate Length Frequency Form for each sampled haul if length measurements of fish or invertebrates were collected

(

Fish / Invertebrate Length Frequencies

Page ____ of ____

Observer code	Vessel code	Trip ID	Date (dd/mm/yy)	Haul											
SLE 0001	12737	33	01/07/10	78											
Species Name	Code	Sex	Mat.	LType	KPC	Length	Count	Length	Count	Length	Count	Length	Count	Length	Count
<i>Yfin tuna</i>	YFT	M		01	449	77	1	85	1	92	3	93	1	94	2
<i>Yfin tuna</i>	YFT	M		01	207	95	6	105	1						
<i>Yfin tuna</i>	YFT	F		01	484	80	1	92	1	99	1	100	3	106	1
<i>Yfin tuna</i>	YFT	F		01	263	110	2	150	1						
<i>Frigate tuna</i>	FRI	M		01	206	35	2	36	1	38	1	44	1	47	1
<i>Frigate tuna</i>	FRI	F		01	113	28	1	37	1	45	1				
<i>bigeye thresher</i>	BTH	M		02	289	288	1								
<i>swordfish</i>	SWO	F		05	286	85	1	199	1						
<i>com. Stingray</i>	JDP	M		11	68	67	1								
<i>com. Stingray</i>	JDP	F		11	90	89	1								
Comments:		Sex:		Common length types:											
		M - Male F - Female I - Indeterminate U - Unknown		01 - Fork 02 - Total 03 - Standard 05 - Lower jaw to fork 11 - Disc width 34 - Carapace length (lobster) 37 - Carapace length (crab) 38 - Carapace width (crab)											

Figure 10-12).

Observer Code:	Record your observer program identification code.
Vessel Code:	Record the vessel code (full list in Appendix 3).
Trip ID	Enter the trip identification number assigned by the SOP.
Date	Record the date haul was retrieved (dd/mm/yy).
Haul	Record the haul number.
Species name	Record the common or scientific name of the measured fish / invertebrate.
Code	Record the 3-letter code (0)
Sex	Enter M, F, I or U for Male, Female, Indeterminate or Unknown. Record Indeterminate when you inspect gonads but are unsure of sex and unknown when gonads are not inspected.
Mat.	Leave maturity column blank – To be added to sampling protocol at a later date.
LType	Codes for the various length types (definitions in Table 10-1 and Table 10-4): 01 Fork 02 Total (fish & crustaceans) 03 Standard 04 Eye to fork 05 Lower jaw to fork 06 Cleithrum to fork 07 Cleithrum to caudal keel 08 Pre-anal fin length 09 Pectoral fin to fork 10 Pre-caudal length 11 Disc width 12 Clasper inner length 30 Crustacean total length –alternate 31 Crustacean total length –alternate 32 Crustacean body length 33 Crustacean body length 34 Crustacean carapace length 35 Crustacean carapace length 36 Crustacean carapace length 37 Crustacean carapace length

- 38 Crustacean carapace width
- 45 Squid mantle length
- 46 Shell height (scallops)
- 47 Shell width (other bivalves)

- KPC** **Key punch check** – Add the lengths and counts for each row and record the sum in the KPC column. This will be used as a quality control check during data entry.
- Length** Record each length to nearest whole centimeter (fish) or millimeter (invertebrates). Record lengths in ascending order.
- Count** Record the count of individuals for each length encountered. Record count of unmeasurable individuals for each species as length=0.
- Comments** There is space at the bottom of the page for comments regarding unusual observations or sampling difficulties.

Fish / Invertebrate Length Frequencies

Page ____ of ____

Observer code SLE 0001		Vessel code 12737		Trip ID 33		Date (dd/mm/yy) 01/07/10		Total 78							
Species Name	Code	Sex	Mat.	LType	KPC	Length	Count	Length	Count	Length	Count	Length	Count	Length	Count
<i>Yfin tuna</i>	YFT	M		01	449	77	1	85	1	92	3	93	1	94	2
<i>Yfin tuna</i>	YFT	M		01	207	95	6	105	1						
<i>Yfin tuna</i>	YFT	F		01	484	80	1	92	1	99	1	100	3	106	1
<i>Yfin tuna</i>	YFT	F		01	263	110	2	150	1						
<i>Frigate tuna</i>	FRI	M		01	206	35	2	36	1	38	1	44	1	47	1
<i>Frigate tuna</i>	FRI	F		01	113	28	1	37	1	45	1				
<i>bigeye thresher</i>	BTH	M		02	289	288	1								
<i>swordfish</i>	SWO	F		05	286	85	1	199	1						
<i>com. Stingray</i>	JDP	M		11	68	67	1								
<i>com. Stingray</i>	JDP	F		11	90	89	1								
Comments:		Sex: M - Male F - Female I - Indeterminate U - Unknown		Common length types: 01 - Fork 11 - Disc width 02 - Total 34 - Carapace length (lobster) 03 - Standard 37 - Carapace length (crab) 05 - Lower jaw to fork 38 - Carapace width (crab)											

Figure 10-12 Example Fish/Invertebrate Length Frequency form.

10.7.2 Specimen Collection

Complete the Specimen Collection Form for each specimen (whole fish, age structures, etc) collected (Figure 10-13).

Observer Code: Record your observer program identification code.

Vessel Code:	Record the vessel code (full list in Appendix 3).								
Trip ID	Enter the trip identification number assigned by the SOP.								
Date	Record the date haul was retrieved (dd/mm/yy).								
Haul	Record the haul number.								
Species name	Record the common or scientific name of the measured fish / invertebrate.								
Code	Record the 3-letter code (0)								
Specimen Type	Record the code for the type of specimen collected								
	<table border="0"> <tr> <td>1 - whole animal</td> <td>2d – thorn</td> </tr> <tr> <td>2a - scales</td> <td>2e - vertebrae</td> </tr> <tr> <td>2b - spine/ray</td> <td>3 - stomachs</td> </tr> <tr> <td>2c - otoliths</td> <td></td> </tr> </table>	1 - whole animal	2d – thorn	2a - scales	2e - vertebrae	2b - spine/ray	3 - stomachs	2c - otoliths	
1 - whole animal	2d – thorn								
2a - scales	2e - vertebrae								
2b - spine/ray	3 - stomachs								
2c - otoliths									
Specimen #	Record the specimen number for this collection. If you are not issued pre-numbered labels, vials or envelopes, start with “1” for each trip and number sequentially throughout the trip. Otherwise, use the number listed on the label, envelop or vial you are issued.								
Sex	Enter M, F, I or U for Male, Female, Indeterminate or Unknown. Record Indeterminate when you inspect gonads but are unsure of sex and unknown when gonads are not inspected.								
Mat.	Leave maturity column blank – To be added to sampling protocol at a later date.								
Length	Record each length to nearest whole centimeter (fish) or millimeter (invertebrates).								
Weight	Record the whole weight of each species to the nearest tenth of a kilogram.								
Comments	Make notes in the comment section as needed.								

Specimen Collection

Page ____ of ____

Observer code <i>SLE 0001</i>		Vessel code <i>12737</i>			Trip ID <i>33</i>			
Date (dd/mm/yy) <i>01/07/10</i>		Haul <i>78</i>						
Species Name	Code	Spec. Type	Specimen #	Sex	Mat.	Length	Weight	Comment
<i>bigeye thresher</i>	<i>BTH</i>	<i>2e</i>	<i>777</i>	<i>M</i>		<i>288</i>	<i>125</i>	<i>Wt was estimated</i>
<i>Ocean trigger</i>	<i>CNT</i>	<i>1</i>	<i>1</i>	<i>U</i>		<i>32</i>	<i>1.6</i>	<i>sp ID verification</i>
<i>yfin tuna</i>	<i>YFT</i>	<i>2c</i>	<i>21</i>	<i>M</i>		<i>77</i>	<i>8.9</i>	
↓	↓	↓	<i>22</i>	<i>M</i>		<i>85</i>	<i>11.9</i>	
↓	↓	↓	<i>23</i>	<i>M</i>		<i>92</i>	<i>15</i>	
↓	↓	↓	<i>24</i>	<i>M</i>		<i>94</i>	<i>16</i>	
↓	↓	↓	<i>25</i>	<i>M</i>		<i>95</i>	<i>16.5</i>	
↓	↓	↓	<i>26</i>	<i>M</i>		<i>95</i>	<i>16.5</i>	
↓	↓	↓	<i>27</i>	<i>F</i>		<i>80</i>	<i>9.9</i>	<i>crushed Left oto - only 1</i>
↓	↓	↓	<i>28</i>	<i>F</i>		<i>99</i>	<i>18.7</i>	
↓	↓	↓	<i>29</i>	<i>F</i>		<i>100</i>	<i>19.3</i>	
<i>yfin tuna</i>	<i>YFT</i>	<i>2c</i>	<i>30</i>	<i>F</i>		<i>150</i>	<i>64.4</i>	

Figure 10-13 Example Specimen Collection form.

10.7.3 Tag Encounter and Recovery

Complete the Tag Encounter and Recovery form for all tags encountered regardless of whether the animal was retained or returned to the sea (example in Figure 10-14).

-
- Observer Code: Record your observer program identification code.
- Vessel Code: Record the vessel code (Appendix 3).
- Trip ID: Enter the trip identification number assigned by the SOP.
- Set No. Record the set or haul number. If not found during fishing, leave this field blank.

Tag Information

Tag number: Record any number or code on the tag and check ONE box for whether this tag was applied (by the observer), was a recapture & the animal was released alive or the tag was removed because the animal was retained or dead.

Tag type	Check the appropriate tag type.
Tag location	Check box for where the tag was attached to the animal's body.
Tag color	Check the color of the tag
Who found the tag?	Record the contact information for the person who found the tag.
Where was tag found?	Check box for whether the tag was found during fishing or during offload. If tag was found during the offload, include the date and location of the offload.

Fish & Invertebrate Information Sections

Species code	Record the species code to the lowest taxonomic level possible.
Length type & length	Record the appropriate code for length type and record the length in cm (fish) or mm (invertebrates). Common codes are listed on the form; the full list and definitions are in Table 10-1 (fish) and Table 10-4 (invertebrates).
Weight type & weight	Record the appropriate code for weight type and record the weight in kg.
Sex	Record the sex of the animal – Male, Female, Indeterminate or Unknown .
Structures collected?	Check appropriate box for any additional structures collected. It is routine to collect otoliths from fish with tags if they are not returned alive.
Comments	Use this space for any additional comments (e.g. unusual injuries or markings, etc).

Tag Encounter and Recovery					
Observer code <i>SLE 0001</i>	Vessel code <i>12737</i>	Trip ID <i>33</i>	Set No. <i>175</i>		
Tag Information					
Tag Number <i>NOAA BET00376</i>		Check one: <input type="checkbox"/> Applied <input type="checkbox"/> Recaptured & released alive <input checked="" type="checkbox"/> Removed			
Tag type	Tag location	Tag color			
<input checked="" type="checkbox"/> Conventional <input type="checkbox"/> Archival (implanted) <input type="checkbox"/> Electronic (other) <input type="checkbox"/> Other	<input checked="" type="checkbox"/> Below 1st dorsal fin <input type="checkbox"/> Behind pectoral <input type="checkbox"/> Opercle <input type="checkbox"/> Belly	<input type="checkbox"/> Carapace <input type="checkbox"/> Other			
		<input type="checkbox"/> Blue <input type="checkbox"/> Green <input type="checkbox"/> Pink <input type="checkbox"/> White	<input type="checkbox"/> Yellow <input checked="" type="checkbox"/> Red <input type="checkbox"/> Orange <input type="checkbox"/> Metal <input type="checkbox"/> Other		
Who found tag?		Where was tag found?			
Name: <i>Mr. Sanusi Minah</i>		<input checked="" type="checkbox"/> During fishing			
Address: <i>1001 34th St, Freetown</i>		<input type="checkbox"/> During offload			
Phone/email: <i>232 - 22 - 101 202</i>		Date: _____ Location: _____			
Fish Information					
Species code <i>BET</i>	Length type <i>01</i>	Length <i>88 S</i>	Weight type <i>01</i>	Weight <i>14.5 A</i>	Sex (M,F,I,U) <i>U</i>
Structures collected?		Length types (combine # & letter)		Weight types (combine # & letter)	
<input type="checkbox"/> Otoliths	<input type="checkbox"/> Scales	<input type="checkbox"/> Other: _____	01 Fork C Curved 02 Total S Straight 03 Standard E Estimated 04 Eye to fork 05 Lower jaw to fork 11 Disc width	Blank - no weight A Actual 01 Whole E Estimated 02 Gilled & gutted 03 Gilled & headed 04 Headed & gutted 99 Other, describe in comment	
Invertebrate Information					
Species code	Length type	Length	Weight type	Weight	Sex (M,F,I,U)
Structures collected?		Length types		Weight types (combine # & letter)	
<input type="checkbox"/> Carapace	<input type="checkbox"/> Eggs	<input type="checkbox"/> Other: _____	02 Total 32 Body 34 Carapace length (lobster) 37 Carapace length (crab) 38 Carapace width (crab)	Blank - no weight A Actual 01 Whole E Estimated 99 Other, describe in comment	
Comments <i>Fish was frozen whole - I was unable to collect sex or an otolith</i>					

Figure 10-14 Example Tag Encounter and Recovery form.

10.7.4 Species Identification forms

There are specific forms for a few groups (billfish, sharks, skates/rays, flatfish/tonguefish, shrimps, scorpionidae and sparidae **Error! Reference source not found.**). Marine mammals, sea turtles and seabirds have their own forms (see next chapter). Most of the forms for fish and invertebrates are self explanatory and ask for counts of various parts and may require some drawing of various anatomical parts. The generic rules for filling out these forms are:

- Species ID forms are required for all animals identified to species and for animals identified to the family or phylum level. If there isn't a group specific form, use the miscellaneous species form.
- If you further identify an organism that only needs to be keyed to family, you must fill out a new form for the identified species (e.g., mantis shrimp unidentified).
- Species ID forms ***must be filled out with the animal in hand!***
- Species ID forms must describe in detail what you observed from your specimen. Do not copy information verbatim from the key or field guide.

11 Marine Mammals, Sea Turtles & Seabirds – Catch, Sightings & Interactions

11.1 Learning objectives

- Describe three features to pay attention to when identifying marine mammals
- Describe three features to pay attention to when identifying sea turtles
- Describe three features to pay attention to when identifying seabirds
- List the main sections of the forms you must complete if you catch a marine mammal or sea turtle

11.2 Introduction

All sea turtles and many marine mammals and seabirds are globally threatened or endangered (IUCN 2008). In order to assess fishery impacts on these species, sightings and fishery interactions need to be reliably quantified.

11.3 List of Priorities

1. Identify all marine mammals, sea turtles and seabirds caught to the lowest taxonomic level possible and complete appropriate forms for the species caught
2. Complete a Marine Mammal and Turtle Sighting and Interaction form for all sightings and interactions

11.3.1 Marine Mammals

Marine mammal interactions with fishing gear can be active or passive. Marine mammals have been documented actively feeding on discards and on longline- or gillnet-caught fish. Fishers may attempt to deter marine mammals from their gear as well. These are typically not fatal interactions and are recorded on the Marine Mammal & Sea Turtle Sighting and Interaction form. Marine mammals are rarely, but occasionally, caught by fishing gear. When this does occur, it needs to be documented thoroughly on the Marine Mammal Carcass Examination form.

11.3.2 Sea Turtles

Like marine mammals, sea turtle sightings are recorded on the Marine Mammal & Sea Turtle Sighting and Interaction form. If a sea turtle is caught incidentally there are specific protocols that should be followed when handling it. These protocols and guidelines have been developed to reduce the risk of further injury to the turtle and to the people handling it. When a turtle is caught, work with the crew to get the turtle on board safely or alongside the vessel if it is too large to bring aboard.

Once a sea turtle has been safely brought onboard or alongside the vessel, your job is to document the catch on the Sea Turtle Capture form (section 11.4.3), take photographs and measurements, retrieve tag information from previously tagged turtles, and assist with removing as much gear as possible from live turtles.

11.3.2.1 Landing and Handling

Upon sighting a turtle caught in gear, the crew should bring the turtle alongside the vessel by slowly and gently retrieving the gear. Gaffs or any other sharp devices should not be used to retrieve the turtle. Turtles less than 90cm in carapace length can generally be brought aboard safely. If the crew is unable to land the turtle due to size or safety considerations, take photos and samples. Ask crew to remove any gear while the turtle remains in the water. The turtle may need a short time to calm down.

11.3.2.2 Dehooking - Longline

Special dehooking equipment has been developed to safely remove longline gear from hooked and/or entangled sea turtles and has been demonstrated to be effective at increasing the post-hooking survival of sea turtles. A 3-year study in the Northeast Distant waters off the East Coast of the U.S. showed that dehooking increased survival for both loggerheads and leatherback turtles.

What are dehookers and what are the incentives for using the equipment?

The most important purpose of the dehooker is to reduce the mortality of turtles by removing the hook from the turtle. Turtle post-hooking survival can be increased when the hook is removed with minimum injury. Fishers assist in sea turtle conservation, retain their hooks (which can be costly), and reduce their re-rigging time. Dehooking a turtle, especially one that is too large to bring aboard, requires cooperation among the crew. This is not a one person operation. Cooperation will result in the best possible release of the turtle.

What if removing the hook may cause more damage?

Deciding whether or not to remove a hook is a judgment call; however, almost all external hooks should be able to be removed. If the hook is in a place where removal may cause further damage to a live turtle, then the hook should be left alone. For example, a hook embedded in the brain or glottis might be best left alone. Remove hooks where the insertion point is visible. Bolt cutters may be more efficient than using a dehooker. Cut the eye or barb of the hook (or flatten the barb) and pull out the other end using longnose pliers. If the hook cannot be removed, cut off as much of the visible part of the hook as possible. Always cut away as much gear as possible on live turtles.

What equipment might you encounter?

There is a wide range of sea turtle handling and dehooking equipment. Some items you may encounter include:

1. Long-handled pigtail dehooker for both external and ingested hooks on turtles that are not boarded (Figure 11-1).
2. Short-handled pigtail dehooker with bite block for both external and ingested hooks. Used on turtles that are boarded (Figure 11-2).
3. Device for pulling an “inverted V”- either the long-handled dehooker for external hooks (J-style) or a gaff
4. PVC pipe – is used to protect the turtle’s beak from becoming damaged from the metal of the dehooker. It also serves to shield the barb of the hook to prevent re-engagement once the hook has been released. The J-style and Scotty’s dehookers are also shown here and are used to remove external hooks that are not too deep.
5. Mouth gags and openers (Figure 11-3)
6. Dip net
7. Bolt cutters

8. Line cutter: a long-handled line cutter can be used to cut the lines from turtles that are released while they remain in the water.

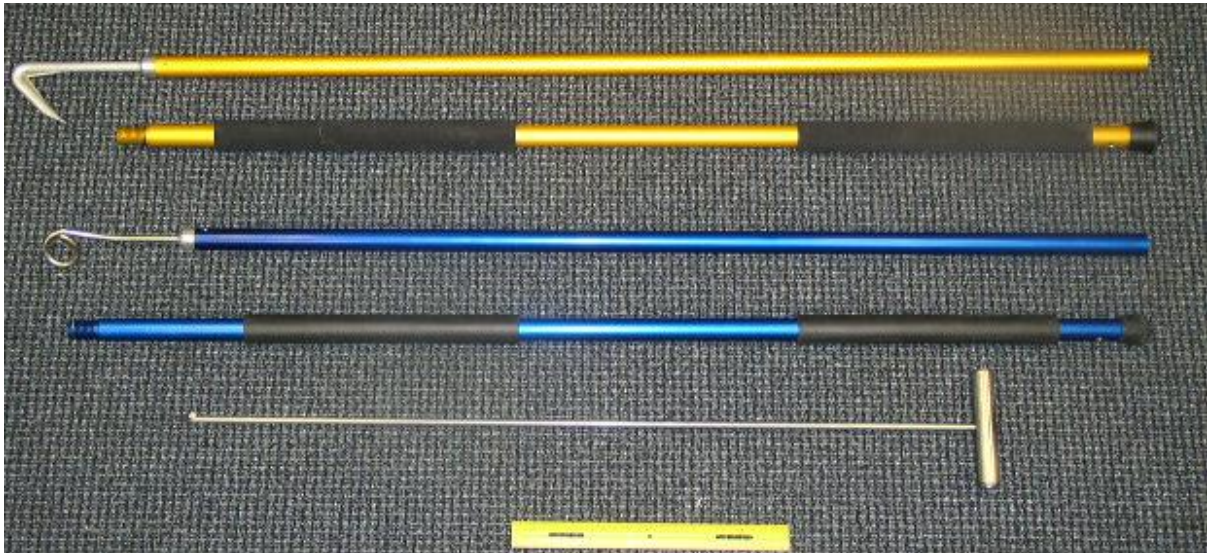

Figure 11-1 Long handled equipment: Line cutter (top), pigtail dehooker (middle) and J-style dehooker (bottom). Images from PIRO (2009).

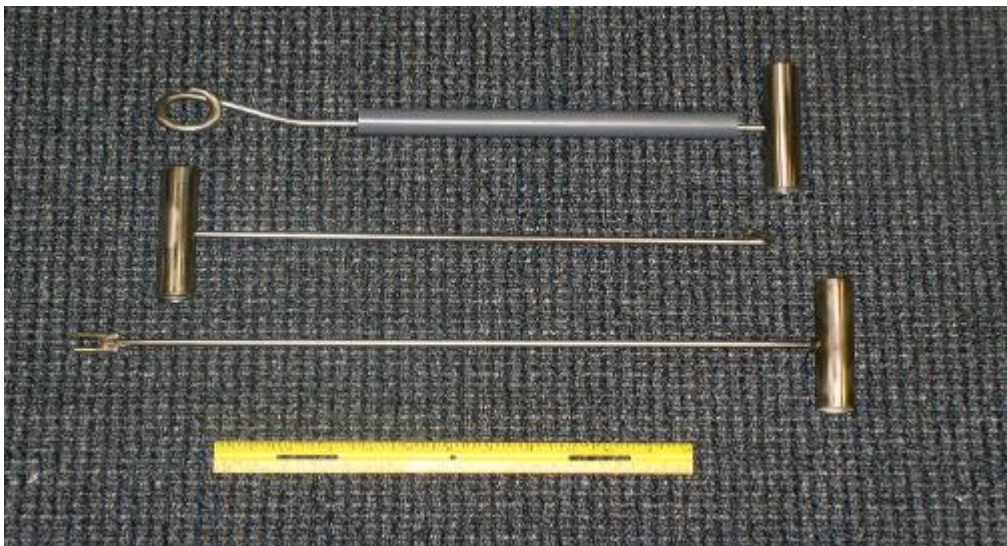

Figure 11-2 Short-handled equipment: pigtail dehooker (top), J-style dehooker (middle), Scotty's dehooker (bottom). Images from PIRO (2009).



Figure 11-3 Examples of mouth openers and gags. Images from PIRO (2009).

How to use a long-handled pigtail dehooker:

1. The person holding the line attached to the turtle should try to stay to the left of the dehooking person while keeping the line taut. The dehooking person should have the line to the left, and the dehooker to the right. Make sure to stay clear of being in between the branchline and the dehooking device because if the line snaps it could be dangerous.
2. The person dehooking will place the dehooker on the line (perpendicular, at a 90-degree angle) with the opening of the pigtail facing up.
3. Pull the device toward you as you would a bow and arrow, until you engage the line.
4. Turn the dehooker a 1/4-turn clockwise, putting the line in the center of the curl.
5. Slide the dehooking device down the line until it engages the shank of the hook and bottoms out. You may have to rotate and move the device back and forth until the top portion of the pigtail is resting on the shank of the hook. This is the proper engagement on the hook.
6. Once engaged, bring the line and the device together making sure the line is tight and parallel with the hooking device.
7. Communicate with the second person so you know when to give slack and when to pull taut and prevent injury. Give a thrust downward until the hook disengages, then gently pull the dehooker upwards, with the hook holding the line taut so the hook is not too loose and does not re-engage.

How to use a short-handled pigtail dehooker:

1. The dehooking person should hold the branchline in the left hand, and the dehooker in the right holding the PVC pipe towards you up against the handle.
2. Place the dehooker on the line (perpendicular / at a 90-degree angle) with the opening of the pigtail facing up.
3. Pull the device toward you as you would pull back on a bow and arrow, until you engage the line.
4. Turn the dehooker a 1/4-turn clockwise, putting the mono in the center of the curl.
5. Release the PVC and slide the dehooking device down the branchline, holding until it engages the shank of the hook and bottoms out. You may have to rotate and move the device back and forth until the top portion of the pigtail is resting on the shank of the hook. Drop the PVC pipe down. This is the proper engagement on the hook
6. Once engaged, bring the line and the device together making sure the branchline is tight and parallel with the hooking device.
7. Give a thrust downward until the hook disengages, then pull up the dehooker holding the PVC down. Hold the line taut so the hook is not loose and can't possibly re-engage.

11.3.2.3 Resuscitation

All turtles that appear dead or comatose (unconscious) should be brought on board to attempt to revive the animal when practical. Turtles can withstand lengthy periods without breathing; a comatose sea turtle will not move, breathe voluntarily or show reflex responses or other signs of life. In other cases, an unresponsive turtle may show shallow breathing or reflexes such as eyelid or tail movement when touched. The following resuscitation techniques should be implemented:

1. Place the turtle on its bottom shell (plastron) so that the turtle is right side up and elevate its hind quarters at least 15cm for a period of 4 to 24 hours. The amount of the elevation depends on the size of the turtle; greater elevations are needed for larger turtles. Use a board, tire or float can be used for elevation. Periodically rock the turtle gently left to right and right to left by holding the outer edges of the shell (carapace) and lifting one side about 7 cm, then alternate to the other side. Gently touch the corner of the eye or eyelid and pinch the tail (reflex test) periodically to monitor consciousness (Figure 11-4). DO NOT put the turtle on its carapace (back) and try to compress the plastron. This may harm the turtle.



Figure 11-4 Elevate a comatose turtle with its head down (left) and periodically pinch the tail to see if there is a reflex response (right). Images from PIRO (2009).

2. Sea turtles being resuscitated must be shaded and the skin kept damp or moist, but under no circumstances be placed into a container holding water. A water-soaked towel placed over the head, carapace, and flippers is the most effective method of keeping a turtle moist, but do not cover its nostrils. Sea turtles may take some time to revive; do not give up too quickly. Turtles that are successfully resuscitated benefit from being held on deck as long as possible (up to 24 hours) to fully recover from the stress of accidental forced submergence.



Figure 11-5 Wet towel placed over turtle to keep turtle cool. Images from PIRO (2009).

3. Sea turtles that revive and become active must be released from the area of the boat that is closest to the water only when fishing or scientific collection gear is not in use, when the engine gears are in a neutral position, and in areas where they are unlikely to be recaptured or injured by vessels. A turtle that has shown no sign of life after 24 hours on deck may be considered dead and returned to the water.

11.3.3 Seabirds

Protocols for seabird sightings and interactions with gear may be developed in the future. The only seabird duty is completing the Seabird Identification form for each new species of seabird encountered in the catch.

11.4 Forms/Instructions

11.4.1 Marine Mammal and Turtle Sighting and Interaction Form

Use this form for marine mammal sightings and interactions (including catch). Sea turtle sightings should also be recorded on this form but sea turtle catch should be reported on the separate Sea Turtle Capture form (Section 11.4.3). Use one form for each sighting or interaction with one or more animals of the same species. If a marine mammal is caught and it is dead, complete a Marine Mammal Carcass Examination Form. If the marine mammal is still alive, release immediately and only fill out the Sighting and Interaction form.

Field	Definition
Observer Name/Code	Record your name and observer code.
Vessel Code	Record the vessel code (Appendix 3).
Trip ID	Enter the trip identification number assigned by the program.
Date / Time	Enter the date when you saw the animal as day/month/yr Enter the time when you first saw the animal (use 24hr notation)
Haul / Set #	Record the Haul or set number if the sighting occurred during active fishing. Otherwise leave blank.
Sighting #	Record the sighting number. Number consecutively as marine mammal sightings are made throughout a trip.
Assoc. Sight. #	Record the sighting number(s) if multiple species are sighted concurrently. For example, if the first group of marine mammals you see contains one Risso's dolphin and two false killer whales, you would complete two sightings forms. One for the Risso's dolphin (sighting #1) and one for the false killer whales (Sighting #2). On the form you would record #2 and #1, respectively, for the Assoc. Sight #.

Sighting Conditions	<p>Circle the relative condition that relates to your view of the animal as affected by ambient lighting, sea state, your position, precipitation, weather, etc. Use the following guidelines:</p> <p>Excellent: visibility clear to the horizon; calm conditions; would easily detect a bird >300m from vessel and a mammal at > 3 km</p> <p>Good: sighting conditions may be affected by glare, sea state, weather or distance; a small bird would be detected to 300m and a mammal at >1 km</p> <p>Fair: conditions affected by a combination of problems such as heavy seas, poor weather or distance; a small bird would be detected to 200m</p> <p>Poor: severely limited visibility (<200m) due to high seas, weather such as fog.</p>
Location	<p>Latitude: enter degrees and decimal-minutes. Circle North or South</p> <p>Longitude: enter degrees and decimal-minutes. Circle East or West</p> <p>If on PS vessel, the time and position should match the Daily Activity Log.</p>
Wind	Estimate the wind speed at the time of observation; record it in knots .
Wave HT	Estimate Wave Height; record it in meters
Water Temp	Record most recently reported surface water temperature (°Celsius)
Species	Enter the common name of the species observed. If more than one species is seen, fill out a separate form for each species and note the association in the Note Box at bottom of form and include Associated Sighting numbers in the Assoc.Sight.# box above.
Species code	Debriefers will enter the 3-letter species code.
Confidence	How certain are you of the species' identification? Circle one of 3 levels of confidence
Body length	Circle the size range that represents the approximate length of the animal seen. Use clues like its size relative to the vessel's length, wave height, or birds nearby.

- Photos taken: Photographs can help confirm the species' identification and document fishery interactions. If you take photographs, please record the frame number (**Frame #**) and indicate on which roll of film (**Roll #**) the photos can be found after they are developed.
- Video? Did you take video footage of the observation or interaction? If so, circle **Y** (yes). Otherwise, circle **N** (no)
- Closest Approach How close did the animal get to the vessel? Record the shortest distance in **meters**
- Initial Sighting Distance Record the initial sighting distance in **meters**
- Number Sighted Estimating the number of animals in a large group can be difficult. Please provide your **BEST** estimate of the total group size. If you are uncertain, record the minimum (**Min**) and maximum (**Max**) number of individuals you believe were in the group.
- Initial sighting cue Circle the initial sighting cue that lead to the sighting
- Initial sighting by: Circle who (or what) made the initial sighting.
- Vessel Activity Circle the appropriate vessel activity when you sighted the marine mammal.
- Notes & Identifying Characteristics Use the large box to provide written and drawn descriptions of the appearance of the animal you saw, the circumstances of its interaction with the gear or vessel, the presence of numbered tags, or to indicate areas of visible injuries
- Behaviors Circle all the behaviors or activities that pertain to the animal(s) you observed (definitions in Table 11-1Table 11-1). There may be many behaviors recorded for each observation reported.

Table 11-1 Marine mammal and sea turtle behavioral descriptions. Modified from (IATTC 1999-2005, AFSC 2007).

Small Cetaceans	Large Cetaceans
<p>Bow riding – Animals swim beside the bow or in the bow wave of a moving vessel.</p> <p>Leaping entirely out of the water – Animal jumps fully clear of the surface of the water (as opposed to merely breaking the surface of the water), not for forward locomotion but</p>	<p>Blow visible for a distance – Blow can be seen from more than 500 m away.</p> <p>Breaching – Animal accelerates forward underwater and then jumps free of the water, sometimes fully clearing the water's surface and then lands on the surface of the water, creating large splash.</p> <p>Flipper slapping – Whale floats or swims at the surface, turns on its side and slaps one pectoral fin against the water, wither once or</p>

<p>for other reasons.</p> <p>Porpoising – Animal raises its body to be nearly or fully out of the water while traveling forward at a fast rate of speed, usually in a fluid, arching motion.</p> <p>Slow rolling – Animal comes to the surface to breathe, with the blowhole and dorsal area usually showing, and then rolls back underwater.</p>	<p>several times in quick succession.</p> <p>Group feeding – Seen primarily in humpback whales, when they coordinate feeding by lunging out of the water with their mouths open, engulfing prey and water.</p> <p>Lob-tailing – Whale raises its tail flukes up out of the water and slaps them down against the surface with great force. This may occur once or be repeated many times.</p> <p>Spy-hopping – Whale is vertical or upright in the water and raises its head up out of the water, usually with its eye showing.</p> <p>Tail raised on dive – When diving the whale’s entire tail lifts completely above the water before going underwater.</p> <p>Side & stern wake riding – Whale is riding in the wake created midships along the side of the vessel or the wake created by the stern.</p>
<p>Sea Turtles</p>	<p>Pinnipeds</p>
<p>Still: floating in the water without apparent movement.</p> <p>Swimming, but not in reaction to the presence of the vessel. If the turtle appears to be swimming to avoid the vessel, circle Other.</p> <p>Feeding: enter this code only if you are sure that the turtle is consuming food.</p> <p>Other/Unknown: any activity that cannot be described with listed behaviors</p> <p>Dead: the turtle was already dead when it was sighted</p>	<p>Jug handle – Seal or sea lion floats on its side with one front flipper and one rear flipper above the water, creating what looks like a handle.</p> <p>Porpoising – Swimming fast & jumping at least partially out of the water in a fluid, arching motion. This swimming pattern resembles that of dolphins seen at a distance.</p> <p>Rafting – A group of pinnipeds resting at the surface together.</p> <p>Spooked from haulout – Pinnipeds which had been resting on beach or rocks dove into the water during to your vessels approach.</p> <p>Vocalizing – Pinniped making direct noises at you or at another pinniped.</p>

Fishing Interactions Marine mammals may interact with fishing vessels and gear in many ways. Check **all** the situations that apply to this observation. Most of the main categories (bold on left side of form) have sub-categories (non-bold on right).

Feeding on catch – also check whether the animal was taking fish off hooks or from the net, feeding on discards or on fish from outside the net (trawl).

Deterrence used – check which type of deterrents were used. Check “Skiff” if a skiff was used to run along the gear (often used in gillnet fisheries).

Boarded vessel – check if the animal came on board the vessel on its own.

Vessel collision – check whether the animal was hit by the hull, propeller or both.

Chased by speedboat – check if MM were chased or herded by speed boat on purse seine

Deployed PS around MM – check purse seine net was deployed around marine mammals

Deployed PS within 100m – check if purse seine net was deployed within 100m of marine mammals

Entangled/captured in gear - For entangled or captured marine mammals, complete the Capture and Release sections of this form as well as the section for the gear type used.

If the marine mammal is dead and in hand, complete the Marine Mammal Carcass Exam form.

Marine Mammal Capture

Capture condition Record the number of individuals for each condition type at the time of capture. For most captures, there will only be “1” individual. Purse seine fisheries are the likely exception.

Note: if the MM is previously dead or unresponsive there are additional questions regarding its condition. Check boxes as appropriate

Was mammal brought on board? Check **Yes** or **No** for whether the MM was brought on board.

Did mammal escape? Check **Yes** or **No** for whether the MM escaped or slid out of gear prior to boarding.

Carcass # If MM was dead and a MM Carcass Examination form was completed, record the carcass # in the space provided.

Marine Mammal Release Information

Date Fill in the date of release (dd/mm/yy).

Time Fill in the time of release. If whole animal was collected, leave blank.

Latitude / longitude Latitude: enter degrees and decimal-minutes. Circle **North** or **South**

Longitude: enter degrees and decimal-minutes. Circle **East** or **West**

If whole animal was collected, leave blank.

Return condition Record the number of individuals for each condition type at the time of release.

Discarded dead, marked – You may be provided further instructions for marking carcasses. If no, record as unmarked.

Discarded dead, unmarked – Carcass returned to sea unmarked.

Salvaged carcass / part – indicate if carcass was salvaged in whole or in part. Do not collect any marine mammal parts unless specifically instructed and you have appropriate permits in hand.

Treated as Catch: The marine mammal was not previously dead and was sacrificed for market, table, or other use.

Released – swam away - animal actively swims away and has no obvious injury

Released – blood visible – animal may swim away but has an obvious injury

Released – sank – animal is not active and sinks upon release

Note: the three ‘Released’ options are hierarchical – record the worst case scenario. For example, if an animal is bleeding AND swims away, the observer should check “Released-blood visible” or if an animal is bleeding and it sank upon release, the observer should record “Released-sank”.

Unknown – provide additional comments in the comment field.

Was there any gear attached to mammal upon release? Record the number of individuals with and without gear attached and describe more fully in the space provided.

Comments Record any additional notes requested in previous fields and any other information related to this capture.

Complete the gear-specific sections as appropriate. Complete header information so that it can be linked with previous pages if forms

Shrimp Trawl

Location relative to TED Note where the MM was caught relative to the TED. Options include No TED, Forward of the TED and Went through the TED

Gillnet

Section caught Record a rough estimate of where the MM was caught in the gillnet. Options include the top 1/3 of the net, the middle 1/3 of the net and the bottom 1/3 of the net.

Animal was able to surface? Check if the animal was able to surface while caught in the gillnet.

Hook & line

Hook type Check the type of hook that the MM was caught on: J, circle or other. If other, make a note regarding the type.

Hook size Record the hook size (usually in ##/# format, 16/0)

Bait If possible, note the bait type that caught the MM.

Hook # Record the hook number from the gear description form. We can link the manufacturer and other information using this field.

Was a light stick on the hook? Check yes or no.

Light stick color If there was a light stick, circle the appropriate color.

gangions to next float Record the number of gangions to the next float.

Hook location Check one as appropriate. If hooked in the jaw/mouth, also note the location in the jaw.

Was the animal entangled in the gear? Circle yes, no or unknown.

Was hook removed? Circle yes, no or unknown.

Purse Seine

Release procedures Circle **Yes**, **No** or **Unknown** for any attempts to release marine mammals from purse seine gear.

If animal was entangled, describe... If an animal was entangled in the net, describe in detail which section it was caught in. Include mesh size and any other features that may be important in developing mitigation to reduce catch in the future.

A

Marine Mammal / Sea Turtle Sightings

Page 1 of

Observer code SLE 0001	Vessel code 12737	Trip ID 33
----------------------------------	-----------------------------	----------------------

Sightings					
Date(dd/mm/yy) 30/07/10	Time (24-hr) 1438	Haul/Set #	Sighting # 3	Assoc. Sighting #	Sighting Condition: Excellent <input type="radio"/> Good <input checked="" type="radio"/> (Circle one) Fair <input type="radio"/> Poor <input type="radio"/>

Latitude **08° 01' 9" N** S
 Longitude **018° 15' 2" E** W
 Wind Speed (kn): **20** Wave Ht (m): **2**
 Water Temp: **29.1** °C

Species: **Humpback whale** Confidence: Sure **Likely** Unsure (circle one)

Species Code: **HUW**

Body Length: <3 m (<10') 3-8 m (10-25') **8-16 m (25-50')** 16-26 m (50-80') >26 m (>80')

Photos: Frame # Roll # Video? Y N
 Closest Approach Initial Sight Distance Number Sighted (Best) Number (Min) Number (Max)

		7	5			1	5	0					3					4
--	--	----------	----------	--	--	----------	----------	----------	--	--	--	--	----------	--	--	--	--	----------

Initial sighting cue:
 Splashes/blow
 Birds Tuna
 FAD Other

Initial sighting by:
 Aircraft
 Crew
 Observer

Vessel activity (circle one):
 Transit/searching Drifting
 Deploying fishing gear Other
 Retrieving fishing gear

Notes & Identifying Characteristics

Include description and drawing of body features, tags, markings, coloration and associated organisms

Captain alerted me to whales ~1430. I went to wheelhouse but it didn't resurface until 1438. We got 2 blows, a couple of views of the dorsal fins and then they sounded. Fluke was deeply forked and had white patches. Body completely dark.



Behaviors

Circle behaviors observed below & describe in "Notes" box

Small Cetaceans <input type="checkbox"/> Bow riding <input type="checkbox"/> Leaping entirely out of water <input type="checkbox"/> Porpoising <input type="checkbox"/> Slow rolling	Pinnipeds <input type="checkbox"/> Jug handle <input type="checkbox"/> Porpoising <input type="checkbox"/> Rafting <input type="checkbox"/> Spooked from haulout <input type="checkbox"/> Vocalizing
Large Cetaceans <input checked="" type="checkbox"/> Blow visible for a distance <input type="checkbox"/> Lob-tailing <input type="checkbox"/> Spy-hopping <input type="checkbox"/> Breaching <input type="checkbox"/> Tail raised on dive <input type="checkbox"/> Flipper slapping <input type="checkbox"/> Side wake riding <input type="checkbox"/> Group feeding <input type="checkbox"/> Stern wake riding	
Sea Turtles <input type="checkbox"/> Still <input type="checkbox"/> Swimming <input type="checkbox"/> Feeding <input type="checkbox"/> Other/Unknown <input type="checkbox"/> Dead	

B

Marine Mammal / Sea Turtle Sightings

Page 2 of

Observer code <i>SLE 0001</i>	Vessel code <i>12737</i>	Trip ID <i>33</i>
----------------------------------	-----------------------------	----------------------

Sightings					
Date(dd/mm/yy) <i>02/08/10</i>	Time (24-hr) <i>0038</i>	Haul/Set # <i>46</i>	Sighting # <i>4</i>	Assoc.Sight. #	Sighting Condition: (Circle one) Excellent Fair <u>Good</u> <u>Poor</u>
Latitude <i>0 8</i> ° <i>0 3</i> ' <i>2</i> <u>N</u> S	Longitude <i>0 2 0</i> ° <i>3 5</i> ' <i>5</i> E <u>W</u>	Wind Speed (kn): <i>30</i>	Wave Ht (m): <i>3</i>	Water Temp: <i>28.3</i> °C	

Species: *Atl. Humpback dolphin* Confidence: Sure Likely Unsure

Species Code: *DHA*

Body Length (circle one) <3 m (<10') 3-8 m (10-25') 8-16 m (25-50') 16-26 m (50-80') >26 m (>80')

Photos: Frame # *#7-10* Roll # *digital* Video? Y N

Closest Approach	Initial Sight Distance	Number Sighted (Best)	Number (Min)	Number (Max)
<i>0</i>		<i>1</i>	<i>1</i>	<i>1</i>

Initial sighting cue:

- *Splashes/blow
- *Birds
- *FAD
- *Tuna
- *Other

Initial sighting by:

- *Aircraft
- *Crew
- *Observer

Vessel activity (circle one):

- *Transit/searching
- *Deploying fishing gear
- *Retrieving fishing gear
- *Drifting
- *Other

Notes & Identifying Characteristics

Include description and drawing of body features, tags, markings, coloration and associated organisms

as we were hauling net, I saw something big inside. The crew dumped the entire net contents on the deck and the dolphin was inside - appears slightly decomposed. Animal is mostly grey, has a medium 'beak' and a puffy hump forward of dorsal fin. It also had what look like gillnet mesh cuts across its face

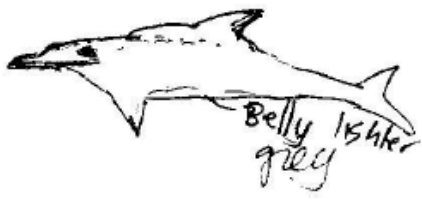

Behaviors
Circle behaviors observed below & describe in "Notes" box

<p>Small Cetaceans</p> <ul style="list-style-type: none"> *Bow riding *Leaping entirely out of water *Porpoising *Slow rolling 	<p>Pinnipeds</p> <ul style="list-style-type: none"> *Jug handle *Porpoising *Rafting *Spooked from haulout *Vocalizing
<p>Large Cetaceans</p> <ul style="list-style-type: none"> *Blow visible for a distance *Lob-tailing *Breaching *Flipper slapping *Group feeding *Spy-hopping *Tail raised on dive *Side wake riding *Stem wake riding 	
<p>Sea Turtles</p> <ul style="list-style-type: none"> *Still *Feeding *Dead *Swimming *Other/Unknown 	

Marine Mammal Interactions

Fishing Interactions (check all that apply)				
<input type="checkbox"/> Feeding on catch	<input type="checkbox"/> Off hooks or from net	<input type="checkbox"/> Fish from outside net (trawl)	<input type="checkbox"/> Discards	
<input type="checkbox"/> Deterrence used	<input type="checkbox"/> Seal bomb (or other explosive)	<input type="checkbox"/> Acoustic device (pingers)	<input type="checkbox"/> Yelling	
	<input type="checkbox"/> Towed on gear	<input type="checkbox"/> Other types of noise	<input type="checkbox"/> Skiff	
	<input type="checkbox"/> TED	<input type="checkbox"/> Other: _____	<input type="checkbox"/> Pole gaff	
<input type="checkbox"/> Boarded vessel				
<input type="checkbox"/> Vessel collision	<input type="checkbox"/> Hit by hull	<input type="checkbox"/> Hit by propeller	<input type="checkbox"/> Hit by hull & propeller	
	<input type="checkbox"/> Chased by speedboat	<input type="checkbox"/> Deployed PS around MM	<input type="checkbox"/> Deployed PS within 100m	
<input checked="" type="checkbox"/> Entangled/ captured in gear				
Marine Mammal Capture				
Capture condition (record # of individuals for each type)		Y	N	U
<input checked="" type="checkbox"/>	Previously dead		<input checked="" type="checkbox"/>	
	Inactive / unresponsive / dead (fresh)		<input checked="" type="checkbox"/>	
	Alive, active, not bleeding, no obvious injury		<input checked="" type="checkbox"/>	
	Alive, active, bleeding, obvious injury			
	Alive, active, unknown condition		Y	N
	Other (describe):	Was mammal brought on board?		
	Unknown	Did mammal slide out or escape from gear?		
				<input checked="" type="checkbox"/>
Carcass # (from Marine Mammal Carcass Examination form)		<input type="text" value="1"/>		
Marine Mammal Release Information				
Date (dd/mm/yy)	Time (24-hr)	Latitude	0 8 ° 0 4 . 0 N S	
		Longitude	0 2 0 ° 5 5 . 1 E W	
Return condition				
<input type="checkbox"/>	Dead - marked	<input type="checkbox"/>	Released-swam away	
<input checked="" type="checkbox"/>	Dead - unmarked	<input type="checkbox"/>	Released- blood visible	
<input type="checkbox"/>	Salvaged carcass / part	<input type="checkbox"/>	Released - sank	
<input type="checkbox"/>	Treated as catch	<input type="checkbox"/>	Unknown	
			Was any gear attached to mammal upon release? Y N	
			If Yes, describe:	
Comments:				
Version 1.0 7/2010				

Marine Mammal Interaction (continued)

Observer code <i>SLE 0001</i>	Vessel code <i>12737</i>	Trip ID <i>33</i>	Haul/Set # <i>33</i>	Carcass # <i>1</i>	
Trawl			Gillnet		
Location relative to TED <input checked="" type="checkbox"/> No TED <input type="checkbox"/> Forward of TED <input type="checkbox"/> Went through TED (in codend)			Section caught: <input type="checkbox"/> Top 1/3 <input type="checkbox"/> Animal was able to surface <input type="checkbox"/> Middle <input type="checkbox"/> Bottom 1/3		
Hook & line					
Hook type: <input type="checkbox"/> "J" <input type="checkbox"/> Circle <input type="checkbox"/> Other _____		Hook size <input type="text"/> / <input type="text"/>			
Bait: <input type="checkbox"/> Squid <input type="checkbox"/> Mackerel <input type="checkbox"/> Other _____		Hook # (gear form) <input type="text"/>			
Was light stick on hook? <input type="checkbox"/> Yes <input type="checkbox"/> No		# gangions to next float <input type="text"/>			
Light stick color (circle): White, Pink, Blue, Green, Red, Yellow, Purple, Other, Unknown					
Hook location: <input type="checkbox"/> Not hooked <input type="checkbox"/> Not known if hooked <input type="checkbox"/> Hooked but location unknown					
Internal: <input type="checkbox"/> Unknown, internal <input type="checkbox"/> Swallowed (esophagus)					
<input type="checkbox"/> Jaw/Mouth - note location in jaw: <input type="checkbox"/> Upper <input type="checkbox"/> Side <input type="checkbox"/> Lower <input type="checkbox"/> Other					
External: <input type="checkbox"/> Unknown, external <input type="checkbox"/> Head/neck <input type="checkbox"/> Rear flipper region <input type="checkbox"/> Front flipper region					
Was animal entangled in gear? Y N U			Was hook removed? Y N U		
Purse Seine					
Was backdown procedure used to assist with marine mammal release?					Y N U
Were divers or a raft used to attempt marine mammal release?					Y N U
If animal(s) entangled in net, describe which section (including mesh size, etc.):					
Version 1.0 7/2010					

Figure 11-6 Examples Marine Mammal and Sea Turtle Sighting and Interaction form. Sighting only (A) and Interaction (B).

11.4.2 Marine Mammal Carcass Examination Form

Complete this form to describe each dead marine mammal examined, using one form per carcass.

IF THE ANIMAL IS ALIVE, RETURN IT TO THE WATER AS SOON AS POSSIBLE!

Field	Description
Observer code	For observer trips, record observer code. If this is a beached carcass, record your name.

Vessel code Record the vessel code (Appendix 3).

Trip ID Record Trip ID assigned by the SOP.

Species / code Record the species common or scientific name and 3-letter species code (0).

Date For observer trips, date of 1st Report and date Examined will likely be the same. However, for beached carcasses, it may or may not be possible to examine a carcass when it is reported. Sometimes the same carcass is reported multiple times.

 Record the day/month/year the carcass was first reported.
 Record the day/month/year the carcass was examined

Gender Determine the animal's gender and circle **M** for male, **F** for female, or **U** if the gender is unknown or cannot be determined

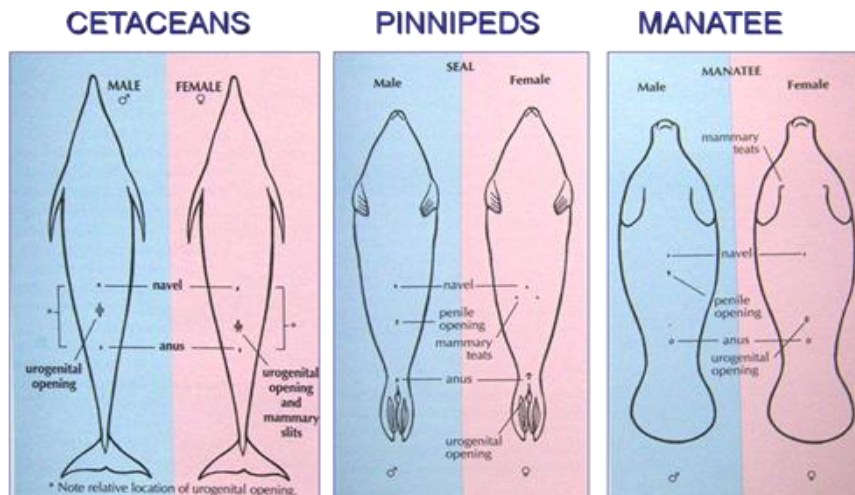

Carcass # Assign consecutive carcass numbers as they are encountered. The same number should not be repeated within a trip.

Weight Record the weight of the animal (kg) and indicate whether this is an **Estimate** or **Actual** measurement of weight

Location Describe the area or region where the carcass was found. Record the **Latitude** and **Longitude** of the location if possible, using the reading from a GPS or calculated from a map. Record degrees and minutes (to nearest 1/10th minute)

External Injuries Examine the animal for injuries around the head, body, flippers, and flukes. Is the animal bleeding? Describe injuries or blood observed.

Tooth Count The number of teeth in each jaw can be used to verify the identity of many species. Starting at the front midline of the jaw, count the

number of teeth in the **Upper Left, Upper Right, Lower Left** and **Lower Right** jaws

- Photos Taken
- Take photos of the carcass if possible, using the one-time camera provided.
- Take a photo of the whole animal and any samples collected from it.
 - Use the Photo Label at the bottom of the datasheet, as explained below

Did you take photographs of the animal? **Yes** or **No**? If yes, record the number of the Frame and Camera/roll where it can be found after the film is developed. Record your name, vessel name/code and trip number on the camera as well.

Measurements

Lengths (A-J): Place the animal on its belly and stretch it as straight as possible. Place the tape measure flat on the surface next to the animal. Place the Zero End of the tape measure at the tip of the snout. Measure and record the distance from the tip of the snout to each of the body parts shown on the data form, measured to the closest 1/10th centimeter.

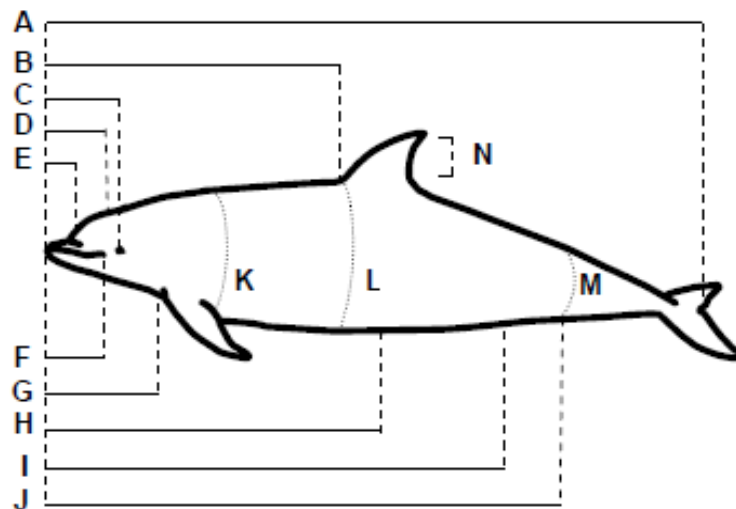

*** IF YOU ARE ABLE TO TAKE ONLY ONE LENGTH MEASUREMENT*...it is most important to measure and record the **TOTAL LENGTH (A)**.**

- On a cetacean or manatee, this is the distance from the tip of the snout to the notch on the trailing edge of the flukes (or greatest length on manatee).
- On a pinniped, this is the distance from the tip of the snout to the end of the tail (not flippers).

Girths (K-M): Girths are measurements made around the circumference of the animal's body at various points along its length. Slide the tape measure under the animal's body, assuring it doesn't twist or fold over itself. With one hand, hold the Zero End of the tape measure

tight to the body. With the other hand, pull the tape around the animal until it overlaps the Zero End of the tape. Hold snugly and read the girth as the measurement where the Zero End meets the tape, to the nearest 1/10th of a centimeter.

*** IF YOU ARE ABLE TO TAKE ONLY ONE GIRTH MEASUREMENT*...** it is most important to measure and record the **AXILLARY GIRTH (K)** this is measured around the body just aft of the animal's pectoral fin or flipper

Appendages (N-Q):

Dorsal fin height: On cetaceans, measure the distance from the top of the dorsal fin to its base on the animal's back. Sometimes the fin will flex here when pulled sideways.

Front flipper: Flex the flipper forward. Measure the

1. flipper's length (O) from its tip to the point of its anterior insertion

2. flipper's maximum width (P) by holding the measure perpendicular to this line and recording the greatest width across the flipper

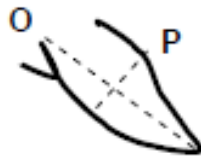

Fluke width: Measure the width of the flukes from tip to tip along the trailing edge. If the flukes are curled, hold the tape along the edge and follow the curve.



Samples Collected

A carcass may be collected whole or parts may be sampled. Place a mark next to each sample collected from this animal. If unlisted samples are collected, mark OTHER and use the blank space to describe those samples.

Photo & Sample Label (Bottom of form)

1) Fill in the information at the bottom of the page, using information from the top of the form.

2) After SAMPLE/PHOTO LABEL is complete, cut it from the bottom of the form and **PLACE IT IN ANY PHOTOS TAKEN WITH THIS CARCASS OR RELATED SAMPLES.**

3) When all photos are complete, **insert this SAMPLE/PHOTO LABEL in the large white sample bag** along with all samples collected.

Marine Mammal Carcass Examination

Observer code <i>SLE 0001</i>	Vessel code <i>12737</i>	Trip ID <i>33</i>	Haul/Set # <i>46</i>	Date (dd/mm/yy)	1st Report: <i>02/08/10</i> Examined: <i>02/08/10</i>
Species <i>Atl. Humpback dolphin</i>			Gender: M <input checked="" type="radio"/> U	Carcass #: <i>1</i>	
			Weight: <i>100</i>	Estimate or Actual	
Location <i>Atlantic Ocean - offshore, west africa</i>	Latitude	<i>08 03.2</i> <input checked="" type="radio"/> N / S			
	Longitude	<i>020 35.5</i> E / <input checked="" type="radio"/> W			
External injuries: <i>previous gillnet injury on head</i>			Tooth Count:	Upper Left: <i>29</i> Lower Left: <i>27</i>	Upper Rt: <i>28</i> Lower Rt: <i>27</i>
Photos taken: <input checked="" type="radio"/> Y / N			Frame # <i>#7-10 (digital)</i>		
Measurements					
Straight line from SNOUT to...					
A notch (Total Length)	<i>196.5</i> cm				
B dorsal fin (ant.insertion)	. cm				
C eye (center)	. cm				
D blowhole (center)	. cm				
E melon	. cm				
F mouth (corner)	. cm				
G flipper (ant.insertion)	. cm				
H umbilicus	. cm				
I genital slip (center)	. cm				
J anus	. cm				
Girths					
K at axilla	<i>54.8</i> cm				
L at dorsal fin insertion	. cm				
M at anus	. cm				
Appendages					
N dorsal fin height	<i>13.2</i> cm				
O flipper length	. cm				
P flipper max width	. cm				
Q fluke width	. cm				
Samples Collected (check all that apply)					
Whole carcass <input type="radio"/>	Jaw <input type="radio"/>	Stomach <input type="radio"/>	Baleen <input type="radio"/>	Other: <input type="radio"/>	
Head only <input type="radio"/>	Teeth only <input type="radio"/>	Reproductive tract <input type="radio"/>	Skin <input type="radio"/>		
Photo Label: Remove label below. Place in all photos taken and then in sample bag with samples					
Marine Mammal Sample					
Observer code	Vessel code	Trip ID	Date (dd/mm/yy)	Carcass #:	
Species	Gender	Total Length	Location:		
Comments					

K.Wynne UAF/NMFS ffwkmw@uaf.edu

Figure 11-7 Example Marine Mammal Carcass form.

11.4.3 Sea Turtle Capture form

The Sea Turtle Capture form is used for recording identification features, capture information, release information and gear-specific characteristics (Figure 11-8). A separate form should be completed for every turtle caught in fishing gear regardless of whether the turtle was brought on board. Sea turtle sightings (without gear interactions) are recorded on the Marine Mammal and Sea Turtle Sighting form (above).

The Sea Turtle Capture form is designed to be completed quickly (e.g., mostly check boxes) with minimal writing so that the turtle can be worked up and returned to the water as soon as possible. Images and field definitions modified from (NMFS 2007b, Southeast Fisheries Science Center 2007, NMFS 2008b, SeaTurtle.org 2008).

Field	Definition
Observer Code	Record your observer program identification code.
Vessel Name / Code	Record vessel code (Appendix 3)
Trip ID	Enter the trip identification number assigned by the program.
Identification	
Species	Check appropriate box for species captured. If unsure of the identification, check Unknown, hardshell or Unknown. Use laminated dichotomous key on deck to identify turtle. See West Africa Species Identification Guide for more details regarding sea turtle identification.
Carapace color	Describe carapace color.
Check Yes , No , or Unknown for whether a) the turtle lacks a hard shell with scutes and b) the nuchal scute touches the first costal scute.	
If the animal has scutes, record counts of left and right costal (lateral) scutes, total number of prefrontal scales, and vertebral scutes (see diagram on form). Left is defined by the observer standing behind a turtle resting on its plastron.	
Dimensions (cm)	Depending on the tools you've been issued, you will measure either the curved (measuring tape) or straight line (calipers) length and width to the nearest centimeter. Curved length is measured along the curvature of the dorsal center line. If you are not issued calipers, record the curved lengths only. If epibiota affect these measurements, record the details in the comments box. If the turtle is not brought on board, estimate the carapace length.
Carapace length	Length is measured from notch-to-tip defined as the center notch of the nuchal scute to the tip of the longest posterior scute (lower left). On leatherbacks, the measurement is taken from the center of the nuchal notch to the posterior tip of the caudal peduncle (lower right from Bolten 1999) along the most dorsal ridge.

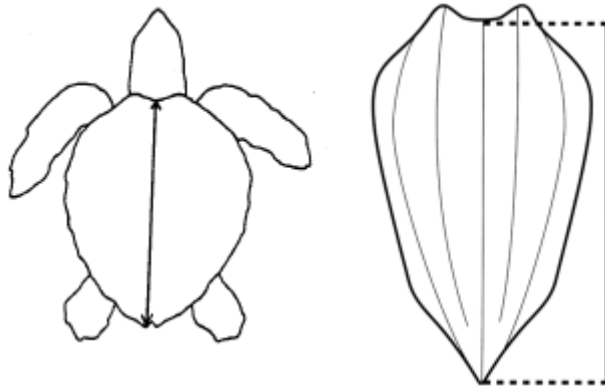

Carapace width Width is the maximum distance between the lateral edges (widest point) of the carapace perpendicular to the centerline at the widest point. On leatherbacks, the width is measured from side ridge to side ridge at the widest point (place measuring tape over the ridges).

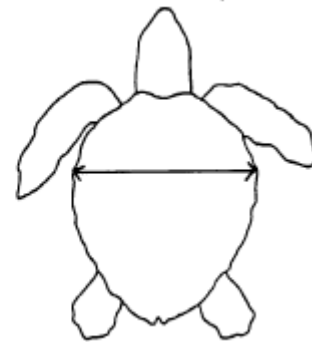

Tags Examine the animal for existing external (flipper or living) and internal (PIT) tags. Metal and plastic tags may be found on any of the four flippers. Living tags are created surgically by removing a small piece of plastron and implanting it on the costal scutes. Living tags are most common for Kemp's Ridley turtles which are primarily found in the western Atlantic.

Number Record the tag number for all tags encountered. If the tag is illegible, record as much as you can and make notes in the comments field.

Metal, Plastic, PIT Record the tag type: **M** for metal, **P** for plastic and **PIT** for Passive Integrated Transponders.

Position Record the position of the tag (options illustrated on figure below): **LF** for left front flipper, **RF** for right front flipper, **LR** for left rear flipper and **RR** for right rear flipper.

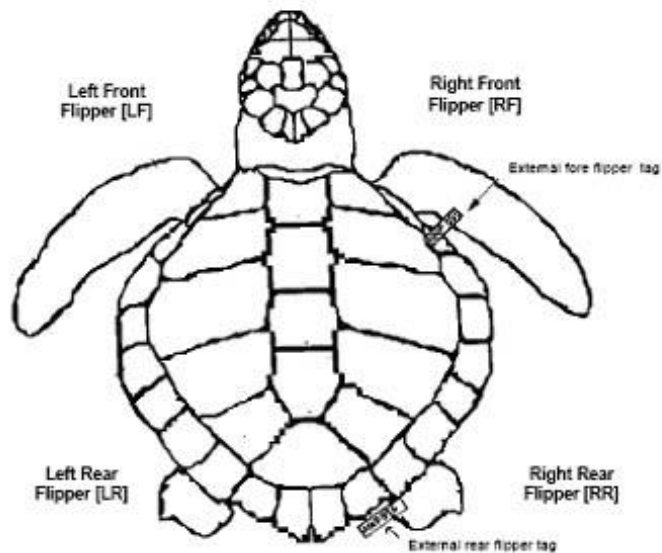

Present or Applied? Record whether tags were already **Present** or if the tag was **Applied** by the observer. The latter requires additional training and gear.

Were tags removed? Enter **Yes** if you removed any tags (e.g., tags that are about to fall off); otherwise, record **No**.

PIT tag scan? Indicate whether or not all four flippers, head and shoulder areas were scanned for the presence of PIT tags. If you were not issued this equipment, check **No**.

Living tag Indicate **Yes** or **No** for whether the turtle had any living tags. If yes, describe.

Biopsy? Was a biopsy sample collected? If yes, indicate the type (i.e., tissue) and provide the specimen #.

Photos Were photos taken? If yes, indicate how many photos were taken and photo numbers (if applicable).

Two photos should be taken of each individual turtle. The first one should be a dorsal view from directly above the turtle capturing the carapace and head. The second photo should be a front view of the animals head and include the head and front section of the carapace. For leatherbacks, try to take photos of the top of the head. Finally, attempt to take photos of the gear interaction and any other interesting observations.

Tip: Most disposable cameras will be out of focus if you stand closer than one meter.

Capture Information

Date	Fill in the date of capture (dd/mm/yy).
Time	Record the time of capture (or time boarded)
Haul/Set #	Record the haul or set number
Turtle Carcass #	Starting at “1” for each trip and number sequentially in increasing order, record the number of the turtle caught.
Water temp	Record the water temperature in °C. If not available, leave blank.
Distance to shore (km)	Note the distance of the location of capture from the shore in kilometers (nearest tenth). The captain can provide this information using the radar or GPS. If you do not know, leave the field blank.
Capture Condition	Check the best condition type at the time of capture. Note: if the sea turtle is previously dead or unresponsive there are additional questions regarding its condition. Check boxes to the right as appropriate

Check **Yes** or **No** for whether the turtle was brought on board, whether it slid out of gear and if resuscitation was attempted. If the turtle is comatose, please follow the instructions on the “how to resuscitate a turtle” guide before release. Also check the box if resuscitation was attempted by the crew or the observer.

Release Information

Date	Fill in the date of release (dd/mm/yy). If whole animal was collected, leave blank.
Time	Fill in the time of release
Latitude / longitude	Record the latitude and longitude (degrees, tenths of minutes and direction) of where the turtle was released.
Water temp	Record the water temperature in °C (if available)
Disposition	Check the most appropriate condition type at the time of release. Discarded dead, marked – You may be provided further instructions for marking carcasses. If not, record as unmarked. Discarded dead, unmarked – Carcass returned to sea unmarked. Salvaged carcass / part – indicate if carcass was salvaged in whole or in part. Do not collect any sea turtle parts unless

specifically instructed and you have appropriate permits in hand.

Treated as Catch: The turtle was not previously dead and was sacrificed for market, table, or other use.

Released – swam away - animal actively swims away and has no obvious injury

Released – blood visible – animal may swim away but has an obvious injury

Released – sank – animal is not active and sinks upon release

Note: the three ‘Released’ options are heirarchical – record the worst case scenario. For example, if an animal is bleeding AND swims away, the observer should check “Released-blood visible” or if an animal is bleeding and it sank upon release, the observer should record “Released-sank”.

Unknown – provide additoinal comments in the comment field.

Comments Record any additional notes requested in previous fields and any other information related to this capture.

Complete the gear-specific sections as appropriate. Complete header information so that it can be linked with previous pages if forms.

Shrimp Trawl

Location relative to TED Note where the turtle was caught relative to the TED. Options include No TED, Forward of the TED and Went through the TED

Gillnet

Section caught Record a rough estimate of where the turtle was caught in the gillnet. Options include the top 1/3 of the net, the middle 1/3 of the net and the bottom 1/3 of the net.

Animal was able to surface? Check if the animal was able to surface while caught in the gillnet.

Hook & line

Hook type Check the type of hook that the turtle was caught on: J, circle or other. If other, make a note regarding the type.

Hook size Record the hook size (usually in ##/# format, 16/0)

Bait If possibe, note the bait type that caught the turtle.

Hook # Record the hook number from the gear description form. We can link the manufacurer and other information using this field.

Was a light stick on the hook? Check yes or no.

Light stick color If there was a light stick, circle the appropriate color.

gangions to next float Record the number of gangions to the next float.

Hook location Check **one** box as appropriate. If hooked in the jaw/mouth, also note the location in the jaw.

Was the animal entangled in the gear? Circle yes, no or unknown.

Was hook removed? Circle yes, no or unknown.

Purse Seine

Release procedures Circle **Yes, No** or **Unknown** for any attempts to release sea turtle from purse seine gear.

If animal was entangled, describe... If an animal was entangled in the net, describe in detail which section it was caught in. Include mesh size and any other features that may be important in developing mitigation to reduce catch in the future.

Sea Turtle Capture

Observer code <i>SLE 0001</i>	Vessel code <i>12737</i>	Trip ID <i>33</i>
----------------------------------	-----------------------------	----------------------

Identification

Species (check one):

<input type="checkbox"/> Leatherback	<input type="checkbox"/> Hawksbill	<input type="checkbox"/> Olive Ridley	<input type="checkbox"/> Unknown
<input type="checkbox"/> Green	<input checked="" type="checkbox"/> Loggerhead	<input type="checkbox"/> Unknown, hardshell	

Carapace color: Dark brown w/red

Does the turtle...

	Y	N	U
Lack a hard shell with scutes?		<input checked="" type="checkbox"/>	
Nuchal scute touch 1st costal scute?	<input checked="" type="checkbox"/>		

Provide counts of the following:

5	Left costal scutes
5	Right costal scutes
4	Prefrontal scales
5	Vertebral scutes

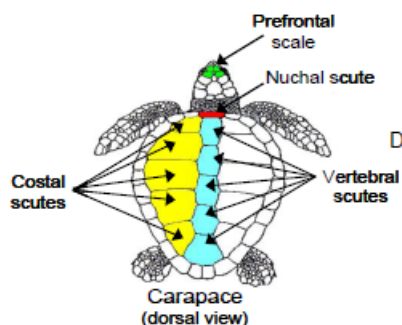

Dimensions (cm):

	Curved (measuring tape)	Straight line (calipers)	Estimate (if not boated)
Carapace length	72		
Carapace width	43		

Tags

Number	Metal, Plastic, PIT	Position: LF, RF, LR, RR	Already Present or Applied by observer	Were tags removed? Y / N
<i>USA 399</i>	<i>M</i>	<i>LF</i>	<i>Present</i>	<i>N</i>

Pit tag scan? No Yes

Living tag No Yes, Describe

Biopsy? No Yes Type: _____ Specimen #: _____

Photos / N
3

Capture Information																				
Date (dd/mm/yy)	Time (24-hr)	Haul/Set #	Carcass #	Water Temp (°C)	Distance to shore (km)															
27/07/10	0845	43	1	28.7																
Capture condition (check one)																				
<input type="checkbox"/>	Previously dead	<div style="border: 1px solid black; padding: 5px; display: inline-block;"> If previously dead or unresponsive, was there: </div>	<table border="1"> <tr><td>Y</td><td>N</td><td>U</td></tr> <tr><td></td><td></td><td></td></tr> <tr><td></td><td></td><td></td></tr> <tr><td></td><td></td><td></td></tr> <tr><td></td><td></td><td></td></tr> </table>			Y	N	U												
Y	N		U																	
<input type="checkbox"/>	Inactive / unresponsive / dead (fresh)	Rigor mortis																		
<input type="checkbox"/>	Alive, active, not bleeding, no obvious injury	Rotting flesh																		
<input checked="" type="checkbox"/>	Alive, active, bleeding, obvious injury	Foul smell																		
<input type="checkbox"/>	Alive, active, unknown condition																			
<input type="checkbox"/>	Other (describe):																			
<input type="checkbox"/>	Unknown																			
	Was turtle brought on board?	<input checked="" type="checkbox"/>	Y	N																
	Did turtle slide out or escape from gear?	<input checked="" type="checkbox"/>																		
	Attempted resuscitation?	<input checked="" type="checkbox"/>																		
	By whom?	<input type="checkbox"/>	Crew	<input type="checkbox"/>	Observer															
Release Information																				
Date (dd/mm/yy)	Time (24-hr)	Latitude	1 0 °	3 5 .	6 N S															
27/07/10	0900	Longitude	0 2 3 °	5 8 .	2 E W															
Return Condition (check one)																				
<input type="checkbox"/>	Dead - marked	<input type="checkbox"/>	Released-swam away	Was any gear still attached to turtle upon release? <input checked="" type="checkbox"/> Y / N																
<input type="checkbox"/>	Dead - unmarked	<input checked="" type="checkbox"/>	Released- blood visible	If Yes, describe:																
<input type="checkbox"/>	Salvaged carcass / part	<input type="checkbox"/>	Released - sank	<i>hook & ~10cm of branchline</i>																
<input type="checkbox"/>	Treated as catch	<input type="checkbox"/>	Unknown																	
Comments:																				

Sea Turtle Capture (continued)

Page 2 of

Observer code	Vessel code	Trip ID	Haul/Set #	Carcass #	
SLE 0001	12737	33	43	1	
Gear Specific Information					
Trawl			Gillnet		
Location relative to TED			Section caught:		
<input type="checkbox"/>	No TED		<input type="checkbox"/>	Top 1/3	
<input type="checkbox"/>	Forward of TED		<input type="checkbox"/>	Middle	
<input type="checkbox"/>	Went through TED (in codend)		<input type="checkbox"/>	Bottom 1/3	
Hook & line					
Hook type:	<input checked="" type="checkbox"/> "J"	<input type="checkbox"/> Circle	<input type="checkbox"/> Other	Hook size	1 6 / 0
Bait:	<input type="checkbox"/> Squid	<input type="checkbox"/> Mackerel	<input checked="" type="checkbox"/> Other	Hook # (gear form)	1
Was light stick on hook?	<input type="checkbox"/> Yes	<input checked="" type="checkbox"/> No	# gangions to next float	8	
Light stick color (circle): White, Pink, Blue, Green, Red, Yellow, Purple, Other, Unknown					
Hook location:	<input type="checkbox"/> Not hooked	<input type="checkbox"/> Not known if hooked	<input type="checkbox"/> Hooked but location unknown		
Internal:	<input type="checkbox"/> Unknown, internal	<input checked="" type="checkbox"/> Swallowed (esophagus)			
	<input type="checkbox"/> Jaw/Mouth - note location in jaw:	<input type="checkbox"/> Upper	<input type="checkbox"/> Side	<input type="checkbox"/> Lower	<input type="checkbox"/> Other
External:	<input type="checkbox"/> Unknown, external	<input type="checkbox"/> Head/neck	<input type="checkbox"/> Rear flipper region	<input type="checkbox"/> Front flipper region	
Was animal entangled in gear?	Y	<input checked="" type="checkbox"/> N	U	Was hook removed?	Y
					<input checked="" type="checkbox"/> N
					U
Purse Seine					

Figure 11-8 Example of Sea Turtle Capture form.

11.4.4 Seabird Species Identification Form

Currently, seabird data collection duties are minimal but may increase in the future. Complete one Seabird Species Identification form (front and back; Figure 11-10) for each new species of seabird caught. Complete header information, circle appropriate foot and bill types and measure total length, tarsus, bill and wing chord to nearest centimeter. If bird is alive, note the foot and bill types and any coloring and release the bird quickly.

If you encounter a dead seabird with a leg band (Figure 11-9) or any other type of tag, make every attempt to retain the bird but definitely the tag.



Figure 11-9 Leg bands. Photo: Patuxent Wildlife Research Center, U.S. Geological Survey.

Seabird Common name: _____ Observer ID: _____
 Date: _____ Haul/Set #: _____ Vessel: _____
 Specimen collected? **Y** **N** Tag #: _____ Photos taken? **Y** **N**
 Length of bird - measure straight line from the tip of bill to longest tail feather: _____ cm

Foot type: (Circle one or describe)

3 webbed toes

3 webbed toes, 4th toe minute, flat heel

3 webbed toes, 4th toe free, with fleshy flap

4 webbed toes

Other foot type, describe and draw: _____
 Foot color: _____
Tarsus measurement: (For all tubenoses and unidentified birds) _____

The tarsus or leg measurement is the long bone connecting the ankle to the foot. It is measured diagonally across the bone from the middle groove of the ankle joint to the top edge of the foot.

Tarsus length: _____ mm
 Leg Placement: _____

All images © COASST 2002. General form structure North Pacific Groundfish Observer Program.

Bill shape: (Circle one or describe)

Hooked bill, Nasal tubes on side

Hooked bill, Arch on lower mandible

Hooked bill, Nasal tubes on top

Duck-like bill with knob

Duck-like bill with leathers

Orange, with grooves, horn or bump

Dark, smooth, pointed bill, arch on lower mandible

Other bill shape, describe and draw: _____

Bill measurement: (All birds)

Bill length or exposed culmen, is the straight-line distance between the tip of the bill and the point where the bill meets the skin or feathers of the forehead. Place one end of the dividers at the tip of the bill and measure the diagonal distance to the forehead feathers.

Bill length: _____ mm
 Bill color: _____

Wing chord measurement: (All birds)

In a relaxed folded wing, the wing chord is the distance between the wrist bend and the tip of the longest primary feather. Do not stretch out the wing. For accuracy, gently lay the wing against the ruler (do not flatten) and line the end of the ruler up with the wrist.

Wing chord length: _____ cm

Additional identifying characteristics or notes: _____

All images © COASST 2002. General form structure North Pacific Groundfish Observer Program.

Figure 11-10 Example Seabird Identification form.

12 Regulations and Compliance

Monitoring

12.1 Learning objectives

- Describe the observer's primary role in compliance monitoring including how observer duties fit within the management framework
- Cite the primary fishing regulations
- Enable observers to make correct decisions for communicating problems
- List the six elements for documenting suspected violations

12.2 Introduction

The observer's role in compliance monitoring is to observe, inform and document (Alaska Fisheries Science Center 2007). The observer's course of action depends on the type of suspected violation and circumstances under which it occurred as well as the actions and demeanor of vessel personnel. Gathering facts and documenting a suspected violation in the observer logbook should be done as part of your routine duties. Remember, **you are not on board to enforce any laws** but if you witness a possible violation, you are expected to document the activities you observe.

12.2.1 Observe

A routine observation of all activities aboard a vessel is your first step in recognizing possible infractions. A violation may be obvious such as using illegal fishing methods like dynamite, but other violations may need further investigation. Observers need to validate their own calculations, measurements and methods prior to documenting a suspected violation. Ask the vessel personnel to clarify any questions you have. By asking these questions you may determine that no violation has occurred.

12.2.2 Inform

If you think a violation has occurred, notify the vessel's captain as soon as possible. Informing the captain is expected unless the captain has failed to respond to previous reports or you feel that it may lead to a potential harassment situation. In these cases, document your reasons for not reporting an incident to the captain in the Daily Notes of the observer logbook. Informing the captain provides him with an opportunity to correct the problem and prevent violations from occurring. Effective communication with vessel personnel requires familiarity with the regulations, good judgment and tact. Organize the facts and approach the captain in a calm and reasonable manner.

The captain's response will shape how the violation is eventually handled. In many cases, the problem will be remedied immediately. If the captain ignores your statements and the violation continues, continue to document each instance. If the problem continues and interferes with your ability to perform your duties, contact the SOP immediately (Appendix 2).

12.2.3 Document

Fully document any suspected violation in the daily notes of the observer logbook (Figure 12-1). Your documentation may be used as evidence; therefore it must be thorough and factual. Omit any subjective or unprofessional commentary. All Daily Notes should be in ink and in chronological order. All entries for suspected violations should contain the following basic elements:

Who: Identify the vessel by name, permit number and vessel type.

- Identify the individuals and witnesses involved by first and last name, position on the vessel and function/duties. Utilize the crew list compiled for the Trip Summary Form.
- Identify who was notified and the nature of their reaction.

What: Describe the event(s) and circumstances in narrative form.

- Include what made you suspicious.
- Detail what was discovered when you looked into the matter
- Describe what occurred (or didn't occur) as a result of your discussions with the captain and crew.
- Use direct quotes whenever possible.
- Record each instance of a suspected violation

When: Identify the exact or approximate time of the suspected violation (i.e., time and date). Include the haul or delivery number if appropriate.

Where: Record the vessel's position (latitude/longitude) or the plant location at the time of the suspected violation. Describe where on the vessel the suspected violation occurred. Draw a diagram if applicable.

Why: Attempt to determine why the suspected violation occurred. Include your own observations and conversations with the crew members that substantiate why the violation may have occurred. Be as objective as possible and cite factors which may provide mitigating or aggravating information.

How: describe the effect the possible violation had on your ability to perform your observer duties. If harassment or intimidation is involved, describe how these actions made you feel.

On July 30, 2010 I witnessed the shrimp trawler, f/v Blue Moon (permit STP03475), fishing in the inshore water area closed to industrial vessels off of Principe Island. Our position was 01° 43' 51.2N and 007°21' 31.24E. I entered the wheelhouse to get some information from the logbook, ~0645 and it seemed like we were closer to land than seemed safe so I glanced at the radar. Land was ~3 nautical miles away and there were 2-3 artisanal vessels between our vessel and land. No vessel names were decipherable on the small vessels. I informed the mate that I thought we might be fishing within the exclusion zone and continued to take down information from the previous day's hauls for my data forms. The mate said thanks for noticing and stated "he must have fallen asleep for a while". By 0655 the vessel had changed course. I took a photo of the radar at ~0700 after the vessel had changed course.

Figure 12-1 Example of suspected violation documentation in Observer Logbook. What is missing?

12.3 Summary of Regulations

For a brief summary of regulations that will impact your next cruise see Appendix 1 (country specific information).

The International Convention for the Prevention of Pollution from Ships (MARPOL) is an international agreement (technically two treaties) adopted in 1973 and 1978 (http://www.imo.org/TCD/contents.asp?doc_id=678&topic_id=258). The purpose of MARPOL is to prevent pollution of the marine environment due to operational or accidental causes. There are six Annexes covering oil pollution (Annex I), noxious liquids (II), harmful substances in packaged form (III), sewage (IV), garbage (V) and air pollution from ships (VI). There are 151 signatories to Annex I/II and 140 to Annex V (Appendix 14).

If you are on a tuna vessel, the following ICCAT resolutions may apply:

Species / Resolution No.

Bigeye (BET)

- 04-01 Purse seine and baitboat closure from 1 November to 30 November between 0°S, 5°N, 20°W and 10°W.

Bluefin (BFT)

- *Longline closure in east Atlantic between 1 June to 31 December except area delimited by West of 10°W and North of 42°N.
- *Purse seine closure from 1 July to 31 December.
- 06-05 *Baitboat & trawl closure from 15 November to 15 May.
- *Use of aircraft to search for BFT is prohibited.
- *Cannot catch/sell BFT <30kg with a few exceptions.
- *20% observer coverage requirements.

Billfish (BIL)

06-09 Maintain daily records of disposition/fate for all blue & white marlin caught.

Bycatch (BYC)

*Vessels may not have onboard fins that total more than 5% of the weight of sharks onboard, up to the first point of landing.

04-10 *In fisheries that are not directed at sharks, CPCs shall encourage the release of live sharks, especially juveniles, to the extent possible, that are caught incidentally and are not used for food and/or subsistence

07-06 Minimize mortality of porbeagle and shortfin mako sharks.

07-07 All vessels fishing south of 20°S must carry and use bird scaring lines.

08-07 Bigeye thresher sharks shall be released.

General (GEN)

94-09 Sightings of IUU tuna fishing must be documented & reported.

05-08 Encourage the use of circle hooks and dehooking devices to reduce mortality of sea turtles in pelagic longline fisheries.

This is not a complete list and vessels are responsible for fishing within whatever catch limits and rules that have been imposed on them by their flag state or state under which they have a fishing agreement. For more information see ICCAT (2009).

12.4 Forms/Instructions

12.4.1 Observer Logbook

Fully document any suspected violation in the daily notes of the observer logbook as per instructions above.

MARPOL – Regardless of whether a flag country or country granting fishing access is a signatory to MARPOL, observers are expected to document instances of oil or plastic disposal events for information purposes. Describe the type and quantity of plastic disposed. For oil spillages, describe the visual appearance (colour, thickness, depth) and estimate the area covered and quantity of the spill.

12.4.2 Compliance Checklist

The Compliance Checklist found in the Observer Logbook must be completed at the **end** of every trip. It is important to ensure the information you collect is kept confidential from the vessel and anyone else except SOP staff. If unsure that a violation has been committed but suspect a vessel has violated its license/permit condition or other fishing regulation, write a full account of the incident, including all evidence that aroused suspicion. The SOP staff will determine if your suspicions are valid and may request further investigation by the Fisheries Patrol or relevant enforcement agency. Although gut feelings on board are often correct, these, unfortunately are not enough to prosecute a vessel. There must be some incident or evidence to back up any suspicions.

Be friendly on board and have a harmonious trip if possible, but remember an observer must put new friendships aside when reporting on vessel compliance. Any attempt by the vessel to

corrupt an observer is illegal and should be noted and reported. Both offering or providing money or gifts are considered bribery. If a vessel is caught fishing illegally and an observer has accepted gifts from that vessel then the observer could be accused of taking a bribe to not report the illegal fishing, which could land them in prison. Connivance, tacit encouragement or assent (without participation) to wrongdoing by another, is also a punishable offence.

Circle **Yes**, **No** or **Unknown** for each of the following (e.g., Figure 12-2). If you answer yes, provide further comments at the end of the form.

Fishing Regulations

- Did the vessel trawl within any inshore exclusion zone or marine protected area?
- Did the vessel possess any fishing nets whose mesh sizes do not conform to prescribed standards and ensure the protection of species?
- Did the vessel use any sort of liner or device to obstruct mesh in trawl nets or purse seine gear?
- Was there respiratory equipment, a harpoon or dangerous fishing weapon (except as a safety precaution) on board?
- Did vessel personnel use explosives, chemicals, poisons or other noxious substances, electrical currents or headlamps, fire-arms, light or automatic traps or any other devices likely to destroy aquatic fauna and the aquatic environment?

Permit/License Conditions

- Did the vessel target species other than those they are licensed to target? Target species are mentioned on vessels' fishing permits. Codend mesh size can also be used as a guide for target species.
- Did the vessel use a fishing method other than the method they are licensed to use?
- Did the vessel retain sublegal size fish?
- Did the vessel sell or possess any protected fishery resources such as sea turtles or marine mammals?
- Did the vessel sell or trade fish at sea?
- Did the vessel not display or present a valid and current license document onboard?
- Did the vessel not display appropriate vessel markings?

MARPOL

- Did you witness the vessel dumping industrial, agricultural or domestic waste?
- Did you witness the vessel dumping plastic?
- Did you witness the vessel discharge oil?
- Did you witness any of the above dumping/discharge by another vessel?

Observer/Vessel Personnel Interactions

- Did the vessel personnel request that an event not be reported?
- Did the vessel personnel offer you a bribe to modify your data?
- Did vessel personnel hinder the observer in the carrying out of their duties?
- Did vessel personnel intimidate or harass you at any time?

Compliance Checklist	
During the trip, did you witness or did the master or crew attempt or do any of the following:	
Fishing Regulations	
Fish within any inshore exclusion zone	<input checked="" type="radio"/> Y / <input type="radio"/> N / <input type="radio"/> U
Fish within any marine protected area	Y / <input checked="" type="radio"/> N / <input type="radio"/> U
Presence on board a fishing vessel of any fishing nets, whose mesh sizes do not conform to prescribed standards	Y / <input checked="" type="radio"/> N / <input type="radio"/> U
Use any sort of liner or device to obstruct mesh (trawl and other net fisheries)	Y / <input checked="" type="radio"/> N / <input type="radio"/> U
Presence on board of respiratory equipment (e.g. scuba), harpoon or dangerous fishing weapon (except as a safety precaution)	Y / <input checked="" type="radio"/> N / <input type="radio"/> U
Use of explosives, chemicals, poisons or other noxious substances, electrical currents or headlamps, fire-arms, light or automatic traps or any other devices likely to destroy aquatic fauna and the aquatic environment	Y / <input checked="" type="radio"/> N / <input type="radio"/> U
Permit/licence conditions	
Target species other than those they are licenced to target	Y / <input checked="" type="radio"/> N / <input type="radio"/> U
Use a fishing method other than the method they are licensed to use	Y / <input checked="" type="radio"/> N / <input type="radio"/> U
Retain sublegal size fish (varies by species)	Y / <input checked="" type="radio"/> N / <input type="radio"/> U
Sell or possess of any protected fishery resources (e.g., turtles)	Y / <input checked="" type="radio"/> N / <input type="radio"/> U
Sell / trade fish at sea	<input checked="" type="radio"/> Y / <input type="radio"/> N / <input type="radio"/> U
Not display or present a valid (and current) licence document onboard	Y / <input checked="" type="radio"/> N / <input type="radio"/> U
Not display appropriate vessel markings	Y / <input checked="" type="radio"/> N / <input type="radio"/> U
MARPOL	
Dumping of industrial, agricultural or domestic waste	<input checked="" type="radio"/> Y / <input type="radio"/> N / <input type="radio"/> U
Dumping of plastic	<input checked="" type="radio"/> Y / <input type="radio"/> N / <input type="radio"/> U
Discharge of oil	Y / <input checked="" type="radio"/> N / <input type="radio"/> U
Dumping of any of the above by another vessel	Y / <input checked="" type="radio"/> N / <input type="radio"/> U
Observer/Vessel personnel Interactions	
Request that an event not be reported	Y / <input checked="" type="radio"/> N / <input type="radio"/> U
Offered a bribe to modify your data.	Y / <input checked="" type="radio"/> N / <input type="radio"/> U
Hinder the observer in the carrying out of their duties	Y / <input checked="" type="radio"/> N / <input type="radio"/> U
Intimidated or harassed at any time.	Y / <input checked="" type="radio"/> N / <input type="radio"/> U
If you answered yes to any of the above, please provide more detail on the event and indicate the logbook page(s) where the event is documented more thoroughly.	
Date / Explanation <i>July 30, 2010 - vessel possibly fishing in inshore exclusion zone. near Principe Is. Documented event on page 32 of observer logbook. Mate moved from area immediately after I notified him</i>	
Date / Explanation <i>July 23, 2010 - vessel trades ~50kg of tuna with an artisanal vessel for ~50kg of whitefish</i>	
Date / Explanation <i>Multiple dates- vessel discarded all rubbish overboard (paper & plastics). See pages 35, 38, 42 and 47 for more detailed description of dumping. I only recorded when I observed but this probably occurred on several occasions that</i>	
Observer signature / Date	<i>K. S. Dutton</i> August 27, 2010
Version 1.0 7/2010	

Figure 12-2 Example of a completed Compliance Checklist

13 Surveillance

13.1 Learning objectives

- Define IUU and describe the impacts of IUU fishing.
- List seven types of information to record if an IUU vessel is sighted.

13.2 Introduction

Vessel and aircraft sightings, especially of vessels fishing illegally, are the primary surveillance duty of observers. The extent and impact of illegal, unreported and unregulated (IUU) fishing is extremely difficult to quantify but it is recognized as both a global fisheries conservation as well as food security concern (FAO 2001a). There has been a steady increase in illegal fishing in the Eastern Central Atlantic Ocean where estimated illegal and unreported catch ranged between 294,000-562,000 tonnes using data from 2000-2003 (Agnew et al. 2009).

13.3 IUU Fishing – What is it?

The FAO International Plan of Action to Prevent, Deter and Eliminate Illegal, Unreported and Unregulated Fishing (IPOA-IUU; FAO 2001a) defines IUU as follows:

Illegal fishing refers to activities:

- conducted by national or foreign vessels in waters under the jurisdiction of a State, without the permission of that State, or in contravention of its laws and regulations;
- conducted by vessels flying the flag of States that are parties to a relevant regional fisheries management organization (RFMO) but operate in contravention of the conservation and management measures adopted by that organization and by which the States are bound, or relevant provisions of the applicable international law; or
- in violation of national laws or international obligations, including those undertaken by cooperating States to a relevant RFMO.

Unreported fishing refers to fishing activities:

- which have not been reported, or have been misreported, to the relevant national authority, in contravention of national laws and regulations; or
- undertaken in the area of competence of a relevant RFMO which have not been reported or have been misreported, in contravention of the reporting procedures of that organization.

Unregulated fishing refers to fishing activities:

- in the area of application of a relevant RFMO that are conducted by vessels without nationality, or by those flying the flag of a State not party to that organization, or by a fishing entity, in a manner that is not consistent with or contravenes the conservation and management measures of that organization; or
- in areas or for fish stocks in relation to which there are no applicable conservation or management measures and where such fishing activities are conducted in a manner inconsistent with State responsibilities for the conservation of living marine resources under international law.

The FAO IPOA-IUU requests nations to voluntarily implement effective MCS in fisheries including:

1. developing an integrated scheme for access to waters and resources;
2. maintaining records of all vessel ownership;
3. implementing VMS where appropriate;
4. implementing observer programs where appropriate;
5. providing training and education to all persons involved in MCS operations;
6. promoting industry knowledge and understanding of the need for MCS and MSC issues within national jurisdictions;
7. establishing and maintaining MCS data; and
8. ensuring effective implementation of national and, where appropriate, internationally agreed boarding and inspection regimes consistent with international law, recognizing the rights and obligations of masters and of inspection officers, and noting that such regimes are provided for in certain international agreements, such as the 1995 UN Fish Stocks Agreement, and only apply to the parties to those agreements.

The IPOA-IUU also calls on States to coordinate their activities and cooperate directly, and as appropriate through relevant RFMOs, in preventing, deterring and eliminating IUU fishing. In particular, States should:

1. exchange data or information, preferably in standardized format, from records of vessels authorized by them to fish, in a manner consistent with any applicable confidentiality requirements;
2. cooperate in effective acquisition, management and verification of all relevant data and information from fishing;
3. allow and enable their respective MCS practitioners or enforcement personnel to cooperate in the investigation of IUU fishing, and to this end States should collect and maintain data and information relating to such fishing;
4. cooperate in transferring expertise and technology;
5. cooperate to make policies and measures compatible;
6. develop cooperative mechanisms that allow, *inter alia*, rapid responses to IUU fishing; and
7. cooperate in monitoring, control and surveillance, including through international agreements.

Surveillance activities depend on rapid identification of fishing vessels. In the mid-1980s, FAO proposed international standard specifications for a vessel identification and marking system (Flewellling et al. 2002). The system proposed based its markings on the International Telecommunications Union (ITU) Radio Call Signs (IRCS) that are unique for each vessel. The size and spacing of each character is dependent upon the length of the vessel. The markings must be in visible locations on the sides of the vessel, and the top of the wheelhouse for air identification. Advantages are for both control mechanisms and rapid identification for aerial patrol efforts and safety-at-sea. International marking standards and a comprehensive global record of vessels is still under development (FAO 2008).

Observer sighting data will be used to quantify IUU fishing in West African waters and provide information to the relevant enforcement agency. Observers will also be documenting gear conflicts with artisanal fisheries.

13.4 List of Priorities

1. Make an entry on the Vessel and Aircraft Sighting form for each suspicious fishing vessel or fishing-related aircraft sighted during your trip.

13.5 Forms/Instructions

13.5.1 Vessel and Aircraft Sightings

The sighting of vessels and aircraft is a very important surveillance role of observers. If vessels are seen that could possibly be fishing illegally, record as much detail as possible on the Vessel and Aircraft Sighting form (Figure 13-1). If the vessel you are on has an AIS system, check it to see if the sighted vessel is recognized. Sightings of currently permitted vessels (Appendix 3) do not need to be recorded unless they are fishing illegally. Appendix 4 is a compilation of known IUU vessels.

Don't hesitate to contact the SOP by cell phone, email or radio, immediately when you see such activity. Include as much information about the vessel and its activities as possible.

Field	Definition
Page ___ of ___	Number pages consecutively for trip and fill in the total pages at the end of the trip.
Observer Code:	Record your observer program identification code.
Vessel Code:	Record the vessel code (Appendix 3) of the vessel you are on.
Trip ID	Enter the trip identification number.
Date	Record date in dd/mm/yy format
Time	Record the time the vessel or aircraft was first sighted
Latitude / Longitude	Record the latitude of the vessel you are on (unit is degrees and minutes to the hundredths of a minute) and include whether it is North or South latitude and East or West longitude.
Direction & Distance	Check the compass and radar for the direction (bearing) and distance from the vessel you are on. If no radar is available, record an estimated distance.
Name	Record the name of the sighted vessel (or as much as you can see or enter 'obscured'). For airplanes and helicopters, record 'aircraft'
Visible numbers	Record any visible numbers or other markings. These could be IMO or other vessel identifier.
Flag	Enter the flag or port – the stern is typically marked with a port city
Type	Record the vessel/aircraft type using codes listed on the bottom of the

form.

Activity Record the vessel activity using codes listed on the bottom of the form. Leave blank for aircraft.

Speed Record other vessel's speed in knots. The captain may be able to use the radar to determine the other vessel's speed.

Hull Material Record hull material: steel, wood, fiberglass, other.

Comments Include any additional information not already included on the form. For example, distinguishing features such, color, design or shape, bridge position, etc. Were there any dents? Were booms up or down? On PS, was chase boat in the water? Was a photo taken? If so, record the frame number.

Vessel and Aircraft Sightings								
Observer code 175			Vessel code XYZ 388			Trip ID 00279		
1	Date (dd/mm/yy) 28/07/10	Time (24-hr) 0835	Latitude (dd mm.mm) 05 47.62	N/S N	Longitude (ddd mm.mm) 015 18.97	E/W W	Direction (deg.) 265	Dist. (nmi) 0.8
	Name Biaeve	Visible numbers	Flag Unknown	Type 2	Activity 2	Speed (kts) 4	Hull material steel	
	Comments <i>Vessel appears to be hauling longline gear. Captain tried hailing on Ch 16 but they did not respond.</i>							
2	Date (dd/mm/yy) 01/08/10	Time (24-hr) 1412	Latitude (dd mm.mm) 05 50.02	N/S N	Longitude (ddd mm.mm) 014 23.75	E/W W	Direction (deg.) 85	Dist. (nmi) 2.5
	Name	Visible numbers	Flag Unknown	Type 9	Activity 6	Speed (kts)	Hull material	
	Comments <i>Helicopter sighted. No information available regarding it's origin/activity.</i>							
3	Date (dd/mm/yy)	Time (24-hr)	Latitude (dd mm.mm)	N/S	Longitude (ddd mm.mm)	E/W	Direction (deg.)	Dist. (nmi)
	Name	Visible numbers	Flag	Type	Activity	Speed (kts)	Hull material	
	Comments							
	Date (dd/mm/yy)	Time (24-hr)	Latitude (dd mm.mm)	N/S	Longitude (ddd mm.mm)	E/W	Direction (deg.)	Dist. (nmi)

Figure 13-1 Example Vessel and Aircraft Sighting form

14 Marine Debris

14.1 Learning Objectives

- Describe three scenarios that would require a Marine Debris Encounter form.

14.2 Introduction

Marine debris, including derelict fishing gear, can impact fishers through fishing gear entanglement, vessel interactions (e.g., with propeller) or catch interaction. Collecting data on marine debris encounters will allow the managing agency to assess the quantity of marine debris in the east Atlantic Ocean.

What is marine debris?

Marine debris is any persistent solid material that is manufactured or processed by humans and directly or indirectly, intentionally or unintentionally, disposed of or abandoned into the marine environment.

14.3 List of Priorities

1. Complete a Marine Debris Encounter form for all vessel interactions and gear interactions on longline, gillnet and purse seine vessels.

14.4 Forms/Instructions

14.4.1 Marine Debris Encounter

If you are on a pelagic longline, gillnet or purse seine fishing vessel, fill out the Marine Debris Encounter form for each encounter with marine debris (Figure 14-1). If you are on a trawl vessel, only complete the form for **vessel** interactions with marine debris. You may be assigned a special project to document gear interactions on trawl vessels.

Field	Definition
Observer Code:	Record your observer program identification code.
Vessel Code:	Record the vessel code.
Trip ID	Enter the trip identification number (assigned by the program prior to each trip).
Haul	Record haul (or set) number if interaction occurred during a haul. Otherwise, leave blank.
Date	Record the date of the encounter.
Time (24-hr)	Record encounter time using 24-hr notation.
Lat-Deg	Record degrees of latitude (2-digits).

Lat-Min	Record the minutes of latitude (to hundredths of a minute; 4-digits)
Lat-N/S	Circle N for all latitudes North of the equator and S for latitudes south of the equator.
Long-Deg	Record degrees of longitude (3-digits) for start and end of each haul.
Long-Min	Record the minutes of longitude (to hundredths of a minute; 4-digits)
Long-E/W	Circle W for all longitude West of the prime meridian (e.g., 0°) and E for longitudes east of the prime meridian.
Incident Type	<p>Check the appropriate box(es) for the type of incident(s).</p> <p>Gear interactions include any encounter with pieces of fishing gear or other equipment put over the side by the vessel.</p> <p>Vessel interactions are with the vessel itself (e.g., line is caught in prop).</p> <p>Entangled species may occur with gear and vessel interactions.</p>
Debris Type	<p>Check the appropriate box(es) for the type of debris.</p> <p>Record the type of net, if possible. For example, gillnet, trawl net, etc.</p> <p>Plastic sheeting only includes tarp-like plastic. If the debris encountered doesn't fit into any of the listed categories, check other and describe in detail.</p> <p>For purse seine vessels, FADs do not count as marine debris. FADs have their own form when on a purse seine vessel.</p>
Biota Type	Check one or more biota types and list species names if known.
Description	Describe the type of incident in more detail, diameter or width, length, colors of line and biota living on the debris.
Weight	Estimate the weight of the marine debris.
Photos	Circle Yes if you took photos and No if not.
Brought aboard	Was marine debris brought on board and retained for disposal? Circle Yes or No .
Length of downtime	Estimate the amount of time the vessel was unable to work due to this interaction.

Downtime / cost Describe what was done during downtime (e.g. propeller disentangled by divers) and estimate the cost to the vessel. Be sure to include the unit of currency.

Marine Debris Encounter

This information is being used to help determine the economic cost of marine debris impacts.

Page 1 of _____

Observer code <i>SLE 0001</i>	Vessel code <i>12737</i>	Trip ID <i>33</i>	Haul No. <i>132</i>
----------------------------------	-----------------------------	----------------------	------------------------

Time & Position of Encounter with Debris (includes vessel, gear and animals)

Date (dd/mm/yy)	Time (24-hr)	Lat-Deg	Lat-Min	<input checked="" type="radio"/> N <input type="radio"/> S	Long-Deg	Long-Min	<input type="radio"/> E <input checked="" type="radio"/> W
<i>18/07/10</i>	<i>0420</i>	<i>09</i>	<i>47.32</i>		<i>020</i>	<i>34.59</i>	

Incident Type (check one or more):

- Gear Interaction
 Vessel Interaction
 Entangled Species Caught (e.g., entangled fish)

Debris Type (check one or more):

- Net: *gillnet*
 Cloth
 Plastic packing straps
 Rope
 Plastic sheeting
 Floats / buoys
 Monofilament line
 Plastic bags
 FAD (fish aggregating device)
 Metal (describe): _____
 Other (describe): _____

Biota Type (check one or more and list species names if known):

- Fish
 Crustaceans
 Encrusting organisms
 No biota/organisms present

Description of incident type and debris object/material (describe the type of incident in more detail, diameter or width, length, colors and biota living on the debris):

Vessel runs over derelict gillnet and gets it wrapped in prop. Gillnet has 14cm mesh and appears to be monofilament (~1m x 1.5m). There are remains of ~10 sharks and bony fish in the net but none are identifiable.

Weight (kg): 75 Photos: Y N Brought onboard for disposal: Y N

Length of downtime (hrs): 3

Description of downtime and cost (describe what was done during downtime (e.g. propeller disentangled by divers) and details of cost):

Two crew sent overboard to cut line from prop. Estimated cost unknown.

Version 1.0 7/2010

Figure 14-1 Example Marine Debris Encounter form.

15 Health & Safety Information

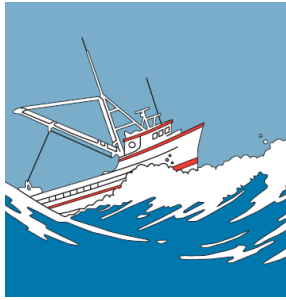

15.1 Learning objectives

- List three dangers inherent to working at sea
- List at least 4 basic competencies required for all personnel (including the observer) on the vessel
- Explain how to deal with a variety of health issues including seasickness
- Describe each of the seven steps to survival
- List essential elements of a personal survival kit
- Demonstrate use of the following safety equipment: EPIRBs, PFDs, VHF and SSB radios, liferafts, hydrostatic release, and fire extinguisher (types, how to use)
- Respond appropriately if a person falls overboard, fire or smoke is detected, or the fire or abandon ship alarm is sounded
- Describe the advantages and disadvantages of 3 types of visual distress signals and include when each is most appropriate to use.

15.2 Introduction

Fishing is one of the most dangerous occupations in the world (ILO 2000). Constant motion, heavy equipment and an inhospitable environment are inherent dangers on a fishing vessel. Thousands of people have died because they weren't familiar with emergency procedures or their safety equipment. Awareness and preparedness should be your main objective. As the observer, you may be the most knowledgeable person on board. Regardless of how cautious the crew is, you are ultimately responsible for your own safety and how you react in an emergency situation could save your life!

15.3 List of Priorities

1. Know your responsibilities regarding safety
2. Complete a Safety Checklist form for each vessel prior to departure
3. Participate in drills when they occur

15.4 Your Safety Responsibilities

There are several international conventions that address fishing vessel safety standards and requirements. The International Convention on Standards of Training, Certification and Watchkeeping for Seafarers was adopted by the IMO in 1978 and was revised in 1995 (STCW-95). A second convention, the International Convention on Standards of Training, Certification and Watch-keeping for Fishing Vessel Personnel (STCW-F), was drafted in 1995 and specifically addresses issues of fishing vessels. STCW-F is not currently in force (www.imo.org). Most West African countries are a signatory to STCW-95 but very few have adopted STCW-F (Appendix 14). Regardless, both documents provide excellent guidelines for minimum requirements for all personnel on board a fishing vessel. Davis and Reynolds (2002) summarize these conventions well stating that "All personnel must perform the following basic competencies:

- i. communicate with other persons on board on elementary safety matters and understand safety information symbols, signs and alarm signals;
- ii. respond appropriately if a person falls overboard, fire or smoke is detected, or the fire or abandon ship alarm is sounded;
- iii. identify muster and embarkation stations and emergency escape routes;
- iv. locate and don life jackets (personal flotation devices or PFDs);
- v. raise the alarm and have basic knowledge of the use of portable fire extinguishers;
- vi. take immediate action upon encountering an accident or other medical emergency before seeking further medical assistance onboard; and
- vii. close and open fire/weather-tight and watertight doors fitted on the particular ship other than those for hull openings.”

Before departure from the dock, observers must complete the Safety Checklist. In order to complete this form, you may need to request a tour of the vessel which can be conducted by the vessel operator or appropriate crew. You should become familiar with:

- i. general safety procedures for that vessel;
- ii. alarm signals used for each type of emergency and alarm locations;
- iii. location and operation of all safety equipment, including fire extinguishers, first-aid kits, life vests, life raft, and communications equipment;
- iv. escape routes from accommodations and/or work areas; Visualize how you would evacuate and retrieve your safety gear from wherever you may be on the vessel. Visualize your evacuation routes with the vessel in different orientations (i.e. on its side, upside down).
- v. where to report (muster stations) and procedures; and
- vi. identification of the person in charge of medical treatment.

If the vessel does not have a life raft with enough capacity for all crew, call the SOP immediately.

15.5 Vessel Hazards

15.5.1 Safety on deck

Fishing vessels have many potentially dangerous areas but the deck typically poses the most hazards. Be aware of your surroundings at all times and keep eyes and ears tuned to vessel activities. The hours, the environment, the food, and the work may be quite different from what your body is accustomed to on land. Slipping, tripping, and falling are the most common causes of injury. Watch out for slick spots where the deck is wet or oily, step carefully over the half-foot combing rising from the bottom of metal latch doors and passageways, and look out for low overheads in vessel stairwells and watertight doors.

Beware of trawl warps under strain. Whenever a cable is subjected to tension, stand out of the way of backlash. Explain to the crew that codend and/or bin/trawl alley measurements may need to be made once the winches have stopped. When nets are being hoisted off the deck, stand clear. Like the trawl warps, these hoisting cables are under great tension. Ask the skipper and crew where they want you to stand when hauling or setting gear.

Talk with the crew about safe places to sample when on deck. Ask where previous observers have sampled. Don't be afraid to voice concerns regarding the sampling area, or to ask for help in making a sampling area safer.

Use proper lifting technique (more on this later)! When lifting, get as close as possible to the object, keep the back straight while using your legs. On a moving vessel, this is critical because unexpected movements can cause back strain. Don't be afraid to ask for assistance in moving heavy baskets or objects.

When outside, remain in full view of a second party at all times. If the weather conditions are too bad for the crew, they're too bad for you as well.

General Deck Safety Tips

- **Always wear a personal flotation device** and appropriate footwear (e.g., boots, close toed shoes) when on deck.
- **Be aware of cables under strain.**
- **Wear protective eyewear** (longline vessels). This will help protect your eyes in the case of a mainline break, sinkers flying back at the vessel after a line break, or any other potential eye hazard.
- Don't run aboard ships, particularly up stairwells.
- Always hold handrails in stairwells and on ladders.
- Always keep a hand free to hang on to the vessel.
- Wear appropriate gear when on deck sampling, rain gear, gloves, hat, etc. Try to stay as warm and dry as possible. Always wear gloves when handling fish.
- Do not stay outside on the deck during rough seas. It is recommended that observers do not go out on the deck alone, especially in rough weather. If you feel that you must go out on deck by yourself make sure you tell someone you are going out on deck.
- Use proper lifting technique.
- Avoid clothes with loose strings or tabs and jewelry such as rings as these might become caught in the equipment or moving belts. Long hair should be tied back.

Safety comes first. If you are unable to collect data due to safety concerns (not only weather), document the particular details of the situation in the Observer Logbook. The report should include a description of the problem, the attempted solutions and the final resolution.

You may encounter a "near miss" (*i.e.* an accident that almost happened) or a specific safety concern during your trip. Documentation of near misses is important. Make sure to notify the debriefer and describe any incidents during our debriefing. Thorough documentation of the incident (what, where, when, and any fixes) can provide valuable information for improving safety training and protection for observers.

15.5.2 Boarding vessels

Vessels at the dock should have a gang plank for safe boarding. If this is not the case, at the very least, a safety net should be attached to the vessel and the dock so that if you slip during boarding, the net will catch you. Be especially aware of wet, slippery surfaces when stepping on to a vessel and be sure of your footing on each step when using a boarding ladder.

15.5.3 Vessel transfers

Transfers between vessels are potentially hazardous, especially in rough weather (NMFS 2008b). You are responsible for deciding whether or not to transfer based upon your evaluation of the transfer conditions. Conditions such as mode of transfer, vessel size, distance to shore, swells versus waves, current and impending weather affect the decision to transfer. Observers must use their best judgment. Be cautious, not foolhardy. Do not be forced into transferring against your better judgment by an anxious or impatient captain. Usually the captain will determine conditions are too rough for transfer before an observer thinks it is too rough. In these cases, the observer must follow the recommendation of the captain who is responsible for the safety of the vessel and personnel aboard (including the observer).

Several methods are available for transfers between larger vessels (>50m). Transfers between vessels may involve using a swing rope or a personnel basket. Given a choice, select the personnel basket for transfers. The swing rope can be potentially hazardous in anything but flat calm seas. Whenever possible, be preceded by an experienced crewman. Stepping, climbing, or jumping from one vessel to another must be executed with extreme caution and proper timing. The following general guidelines should be followed during all transfers:

1. Observers will wear PFD's, during all transfers.
2. Observers will not encumber themselves with baggage when transferring. Balance is critical and both hands must be free during transfers especially to canoes. Baggage should be handed across after the transfer is completed or sent across by basket or cargo net.
3. If a personnel basket is to be used, make sure a guide line is attached to the basket and manned for greater control and to reduce swinging when landing the basket on deck. Baggage should be securely stowed in the center of the personnel basket. The following procedures should be used during personnel basket transfers:
 - a. Stand with one foot on the outer ring of the basket, the other on the deck and both hands securely holding the netting.
 - b. As the basket lifts off the deck, bring your foot off the deck and place it on the outer ring of the basket next to your other foot (already on the basket ring).
 - c. Stand firmly on the outer ring with knees slightly bent as opposed to locking your knees to avoid leg or back injury in the event of a hard landing. Carefully step off the basket when it has landed firmly on the deck.

15.5.4 Bacteria and Fungus

Bacteria from fish may lead to infection in cuts, scrapes, or punctures. To prevent “fish poisoning” always wear gloves when handling fish and wash your hands thoroughly with soap and water after sampling. Change gloves often to keep them dry and discard any torn gloves. Treat *all* minor cuts, especially those on your hands, with antiseptic to avoid infection from fish slime.

Be cautious whenever wading through fish on deck. Fish spines, especially on the Ariidae and stingrays, can penetrate rubber boots and cause painful puncture wounds to the feet. Spines often carry bacteria and can lead to fish poisoning.

If a wound gets red or swollen, soak it for ½ hour in very hot, soapy water at least three times a day. Dry and bandage the wound. Antibiotics are commonly prescribed for fish poisoning.

The vessel may have some on board. Never leave an infection untreated--the threat to your health can become much more far-reaching than simply a pair of inoperative hands.

Take extra precautions against infection when collecting specimens from marine mammals. “Seal finger” is a fungal infection of the hands that can easily be contracted by a scratch or bite.

15.5.5 Heavy lifting and repetitive motion issues

The duties of an observer are physically demanding. The job requires not only heavy lifting but also repetitive motions. Serious back injuries can occur due to improper lifting technique (see text box for Heavy lifting tips) and carpal tunnel syndrome can occur from repetitive motions of the hands and arms.

Carpal-tunnel syndrome can occur from by any abnormal strain on the tendons caused by repetitive motion. This may cause chaffing or swelling which creates pressure on the median nerve as it passes through the tight carpal tunnel in the wrist. Symptoms include numbness or tingling in your hand, pain in your wrist, palm or forearm, trouble gripping objects and more pain at night. You can prevent carpal tunnel by doing arm, wrist and hand exercise prior to being deployed.



15.5.6 Radar

Radar emits radiation that can cause injury. Do not stand near the radar when it is turned on.

15.6 Personal health & safety

In addition to the hazards already discussed, vessels pose a variety of personal health and safety risks ranging from illness and accidents to harassment. Report any injuries, accidents or illnesses that occur at sea to the captain immediately and to the SOP upon return to port.

General tips

- Avoid drugs and alcohol aboard fishing vessels. Stay sober at all times.
- Drink plenty of water and eat regularly.
- Wash hands frequently with hot soapy water and/or sanitizer to avoid illness and infections. Treat all cuts, burns and other wounds seriously and apply appropriate first aid to avoid infections.
- When you are not feeling well, use extra caution and reduce the time spent working.
- Be aware of confined spaces, such as sleeping quarters that contain chemicals. Fumes can build up in confined spaces and make people ill or even kill them.
- Bring things from home that comfort you and can occupy your time during slow periods. Books, magazines, games, favorite articles of clothing, pleasant smells, are examples of things you could bring along. These will help you mentally deal with the sometimes psychologically straining effect of life at sea on a fishing vessel.

Heavy lifting tips

1. Plan ahead before lifting – Knowing what you're doing and where you're going will prevent you from making awkward movements while holding something heavy. Clear a path, and if lifting something with another person, make sure both of you agree on the plan.
2. Lift close to your body – You will be a stronger and more stable lifter if the object is held close to your body rather than at the end of your reach. Make sure you have a firm hold on the object you are lifting, and keep it balanced close to your body.
3. Feet shoulder width apart – A solid base of support is important while lifting. Holding your feet too close together will be unstable, too far apart will hinder movement. Keep the feet about shoulder width apart and take short steps.
4. Bend your knees and keep your back straight – Practice the lifting motion before you lift the object, and think about your motion before you lift. Focus on keeping your spine straight--raise and lower to the ground by bending your knees.
5. Tighten your stomach muscles – Tightening your abdominal muscles will hold your back in a good lifting position and will help prevent excessive force on the spine.
6. Lift with your legs – Your legs are many times stronger than your back muscles--let your strength work in your favor. Again, lower to the ground by bending your knees, not your back. Keeping your eyes focused upwards helps to keep your back straight.
7. If you're straining, get help – If an object is too heavy, or awkward in shape, make sure you have someone around who can help you lift.
8. Never jerk or twist

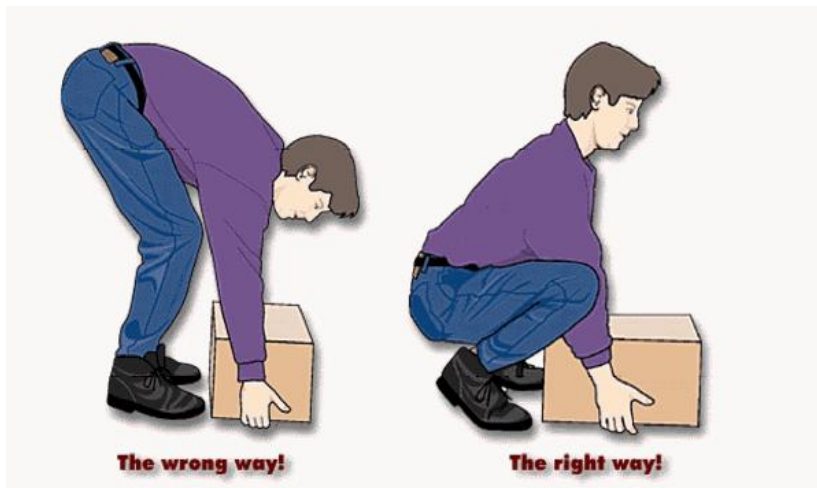

Figure 15-1 How to lift by Jonathan Cluett, <http://orthopedics.about.com/cs/backpain/ht/lift.htm>, February 25, 2007.

15.6.1 Hydration

Drinking plenty of water and eating enough food are two critically important factors in maintaining health in this new environment. Adults require a minimum of 2 liters of water per day and water needs increase in the tropics and with physical exertion (Jensen and Dzigan 2005). If urine is dark or you have a headache, you may be dehydrated.

15.6.2 Hyperthermia & Hypothermia



Figure 15-2 High heat loss/gain areas – head, neck, sides of chest and groin region. (Image from (Transport Canada 2003)).

Hyperthermia, or heat exhaustion, is an acute condition which occurs when the body produces or absorbs more heat than it can dissipate. Early symptoms include weakness, pale skin, headache and profuse sweating. The next phase involves the skin becoming hot and bright red. If not treated, hyperthermia may lead to heat stroke. Heat stroke occurs when the victim stops sweating and loses consciousness. Additional symptoms include confusion, headache, hostile behavior, the appearance of intoxication, and dizziness due to a drop in blood pressure. Dehydration plays a large role in hyperthermia because the body may not be able to sweat, a major source of heat loss. The primary treatment is cooling the person down by moving indoors (or shade), remove clothing, place in cool water, and cool compresses applied to the torso, head, neck and groin (Figure 15-2). Rehydration is also critical for treating hyperthermia.

Hypothermia occurs when the body's core temperature drops. It can occur when submerged in water less than 33°C and in air less than 27°C. Although the water temperatures off of West Africa range from 22-30°C, hypothermia can still occur. Water conducts heat away from the body 25 times faster than air at the same temperature (Jensen and Dzugan 2005). The Man Overboard section of this chapter discusses appropriate action to take if you find yourself in the water.

15.6.3 Fatigue and sleep deprivation

Fatigue and sleep deprivation suffered by the crew and by the Observer are threats to everyone's safety. Be aware of the physical state of other people on the vessel—whether the person on watch or in control of the gear. Fatigued individuals make mistakes. Monotonous work is difficult to do accurately and safely when tired. Try to “catch up” on sleep when there are breaks in fishing.

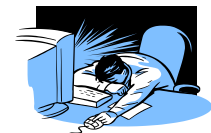

15.6.4 Noise

Engine noise is not only annoying—it keeps boat operators from hearing voices, signals, and danger warnings. If you're around a loud noise for a long time, the noise can make you tired and lower your reaction time.

15.6.5 Seasickness



One of the least pleasant aspects of going to sea is the possibility of seasickness. An individual's susceptibility to seasickness is highly variable. Individuals that have experienced motion sickness in cars or buses may experience seasickness during their trips. The symptoms of motion sickness include nausea, vomiting, and dizziness. Other common signs are sweating and a general feeling of discomfort and not feeling well (malaise). Most people feel some level of discomfort when they first go to sea.

Seasickness is a result of a conflict in the inner ear (where the human balance mechanism resides) caused by the erratic motion of the ship through the water. Inside the cabin of a

rocking boat, for example, the inner ear detects changes in linear and angular acceleration as the body bobs with the boat. But since the cabin moves with the passenger, the eyes register a relatively stable scene. Agitated by this perceptual incongruity, the brain responds with stress-related hormones that can lead to nausea and vomiting. Its effect can be magnified by strong smells (like diesel fumes or fish, which are part of daily life at sea). Seasickness usually occurs in the first 12-24 hours after sailing. For most people, seasickness dissipates when the body becomes acclimated to the ship's motion (getting one's "sea-legs"). In rare cases, an individual may stay ill beyond the first couple of days at sea, regardless of sea state. If this occurs, dehydration can become life threatening if it leads to shock.

You may choose to take seasickness medication before going to sea. There are several over-the-counter and prescription medications available to minimize seasickness. Acupressure wristbands and eating crystallized ginger are other remedies used with varying success. Seasick medications must be taken before the symptoms begin. Most medications take several hours to be absorbed into the body. If you are vomiting and cannot keep anything in your stomach taking medication at sea will not be an option. Even if you doubt that you will get seasick, you might want to take the medication before you board as a precaution. If you should get seasick, take comfort in the fact that recovery is only a matter of time. All that is usually required for a complete recovery is some patience.

Seasickness tips:

- Keep drinking fluids. Seasickness and related medications cause dehydration and headaches. Try to drink juices low in acidity, clear soups, or water, and stay away from milk or coffee.
- Continue eating items like crackers, dry toast, dry cereal, etc. (avoid anything greasy, sweet, or hard to digest). Keeping something in your stomach suppresses nausea, or, when vomiting, eliminates painful "dry heaves".
- Focus on the horizon to eliminate the visual conflict in your brain.
- The vessel's motion is generally less pronounced the further astern you go. Try to stay as far back from the bow and on lower decks, if possible.
- Keep working. Most people find that being busy on deck keeps their minds off their temporary discomfort. Also, the fresh air out on deck is often enough to speed recovery.
- Carry a plastic bag. This simple trick allows some peace of mind and eliminates some of the panic of getting sick. When vomiting over the side, be aware of which way the wind and waves are coming. Going to the leeward side will ensure that an unpleasant experience doesn't become any more unpleasant.
- Don't be embarrassed or discouraged. When Observers are seasick, chances are that others people on board are seasick too! No one is immune to seasickness.

Modified from (NWFSC 2006).

15.6.6 Harassment

Observers can be subject to negative attention, comments, or actions because vessels often see them as unwelcome government agents or even "fish cops".

15.6.6.1 Identifying Harassment

Harassment can take many forms such as:

- Repeatedly waking an observer during sleep periods.
- Providing substandard accommodations and food.
- Criticizing or interfering with an observer's sampling techniques or reporting practices.
- Excessive/inappropriate teasing or ribbing.
- Intentionally throwing discarded species over that are requested by the observer.
- Tampering with an observer's gear or sample.

- Intimidating an observer.
- Barring an observer from areas they need access to do their job

In all cases, harassment is defined as when the observer feels threatened or feels that their work or living environment is being compromised.

15.6.6.2 Sexual Harassment

Sexual harassment is unwelcome behavior of a sexual nature. Privacy is greatly reduced onboard a vessel, and interactions can become intense very quickly. Sexual harassment may include sexist remarks or behavior, or sexual advances which result in a tense and unproductive work environment. Examples of sexual harassment include:

- Suggestive sounds or gestures
- Sexual remarks about ones clothing, body or sexual orientation
- Leering or ogling
- Persistent sexual comments and jokes
- Constant brushing against or touching a person's body

Sexual harassment is unwanted attention in a nonreciprocal relationship (relationships with vessel personnel are prohibited under observer standards of conduct). In most normal interpersonal relationships, an individual can exercise free choice in deciding to develop a relationship based on mutual caring and respect. These elements are absent in sexual harassment. If you feel sexually harassed remember that it is not your fault! Take the appropriate steps to address the situation, contact help, and document thoroughly.

15.6.6.3 What to Do if Observers Experience Harassment

Observers who experience harassment in any form should confront it directly and document it completely. By reporting harassment, you protect future observers as well as yourself. Please report any cases of harassment to the SOP as soon as possible. The SOP is unable to help with problems if they are unaware of them.

Tip* Observers should not feel embarrassed to report harassment or worry that they did something to provoke the unwanted behavior. Remember, unreported harassment not only affects your ability to do your job but it will set a precedent for the treatment of future observers on that vessel.

Follow these steps when you experience harassment:

Tip* Remember that you are the judge of whether another person's actions negatively affect you.

1. The **FIRST** time an observer feels uncomfortable or feels that a crew member has crossed a line, tell the offender to **STOP**. In this conversation the harasser should be told that his/her comments, actions or advances are unwanted and that they should stop.
2. Don't fight fire with fire. Observers should behave professionally at all times. Make sure that verbal and non-verbal body language exhibit a clear message to the harasser to stop.
3. Document all harassment incidents from the very beginning in the observer logbook. Record the details of the event assuming that the harassment could escalate. It is easier to do it initially than to come back and reconstruct it weeks later. In the logbook, describe the situation, including who, what, where, when, why and how (see page 12-2). Be as detailed as possible. Use direct quotes, accurate times and dates, any witnesses present, circumstances surrounding the event and any other important details. Detail the attempts made to end the harassment and the response that was received.

4. If the initial harassment is egregious or if the problem continues after clearly asking the harasser to stop, report it to the skipper. Tell the skipper the full story, explain that it is affecting your work, and request that he take steps to end the problem. Most skippers do not want trouble on the boat. If the skipper is informed that trouble is brewing, he should take appropriate action. Document any further incidents and the skipper's actions.
5. If the harassment is not taken care of by the skipper, if the issue is with the skipper, or if there are other problems with the skipper, report the offense to the SOP at the first opportunity, use your cell phone at sea if necessary. If there is no resolution, the SOP will make arrangements for you to leave the vessel.

15.6.6.4 Advise to Observers (adapted from "Advise to women" in NMFS 2008b)

Sexual harassment, ranging from verbal harassment to assault and rape, can affect both women and men. Such incidents are frequently not reported, for reasons ranging from a desire to be a good sport in minor cases to embarrassment and shame in more serious cases. This section is intended to alert you to the different nature of social conditions at sea, and to suggest some actions you should take if you feel uncomfortable or harassed.

Social conditions are different from those on land. Privacy is greatly reduced, and as a result, interactions can become more intense and feelings of intimacy are more quickly established. Small incidents, both pleasant and unpleasant, can quickly take on exaggerated importance, due to the close quarters, the prevalence of gossip, and the sense of isolation from "the real world" back on shore. Furthermore, staffing on a ship brings together people with very diverse backgrounds and value systems. While some of the men are accustomed to the concept of women as professionals, others are familiar with more traditional views of women. For some men, sexual remarks or actions may be considered an acceptable mode of behavior regardless of location. Also, the value systems of many men change somewhat during the period of time that they are at sea. Homosexual behavior at sea may be socially acceptable by some cultures that reject these actions on land.

The crew has usually established a workable interaction among themselves, while observers, who come aboard for a single trip, are not part of that system.

Sexual awareness and tensions can be heightened at sea, due to the unusual social closeness and deprivation of normal outlets. Behavior and attire that are acceptable on shore can be viewed as provocative at sea and close relationships between people can strongly affect the atmosphere in which everyone must work and live. Observers, especially women, are therefore particularly apt to draw attention, comment, and speculation. While some of the attention may be pleasant and even flattering, some of it is not.

In consequence, it is necessary to be aware of the different social situation, to consider the consequences on some situations and to modify your normal behavior if necessary. Below are some examples of the sort of actions you might adopt or avoid:

1. Strictly obey the rules regarding drinking, which can lead to poor judgment, lack of control, and alertness, and hasty actions. At sea you must be prepared for any emergency. Consider yourself on duty 24 hours a day.

2. Refrain from wearing potentially provocative clothing such as sleeveless tops, short shorts, and tight clothing.
3. Be aware that if you show more attention to one crewman, it may be misinterpreted by him or by others.
4. Do not invite crew to your cabin if you are alone, or accept an invitation to be alone with him for a "friendly chat" or "little drink". Women should go to a public area if a man comes to talk to you without your invitation.
5. Activities such as flirting, joking about sex, or touching may be misinterpreted by the persons involved or by others. Unwanted approaches such as these should be responded to politely but very firmly. You yourself should avoid flirtatious behavior.
6. Do not engage in sexual affairs. These distract you and your partner from doing your work, can breed resentment and jealousy and will subject other observers to increased sexual pressure, both on your trip and on subsequent trips. Physical involvement is a violation of the programs code of conduct.
7. Make it clear that your interests in companionship are elsewhere or that you are "not available".
8. If you are experiencing unwelcome advances or are in any tense situations, do not stand around on deck or other deserted areas alone at night.
9. In general, be very sensitive to the altered social conditions and their possible implications. Be very conservative. Use common sense.

An assault often occurs with warning signs of milder behavior. If you act firmly and decisively during the early stages, you may reduce the chances of future harassment. Some warning signs to watch for are:

- Frequent attempts to detain you, to be in your company, or to visit you in your cabin.
- Mild or casual sexual remarks become more frequent, pointed and/or objectionable.
- Any physical contact, even if it appears innocent.
- Other people warn you about a man who begins to harass you.
- A person whom you have repeatedly attempted to discourage continues or escalates the advances.

The definition of harassment is subjective (see Chapter 12), making it difficult to identify. Sexual harassment can be defined as "unwelcome sexual advances, requests for sexual favors, and other verbal or physical conduct of a sexual nature." Thus, it is your decision at what point you will draw the line.

Many women and men feel uncomfortable with milder forms of harassment, but tolerate it, not wanting to cause trouble, or appear to be oversensitive or bad sports. The unfortunate result of this passivity is that harassment may continue or increase until it becomes serious. At that point, the observer is open to the charge that s/he allowed or encouraged the previous actions. It is best to take action at the time you first feel uncomfortable. There are a variety of actions you may adopt, which must depend on your judgment. In general, the best sequence to follow is:

1. Indicate to the harasser that you do not enjoy or appreciate his actions. Do not make a joke of his behavior. Speak firmly and coldly, or pointedly avoid him. Do not make the mistake of pretending to ignore it; this invites continuation at a higher level. Losing your temper may be effective in some cases but usually is not, and may even encourage the harasser.

2. If the above measures are not immediately effective in stopping the harassment, bring the matter to the attention of the captain and tell him to immediately solve the problem or you will request to be removed from the vessel.
3. If the problem continues, call your supervisor and report the incident. Inform the captain he will need to make immediate arrangements to return you to port. If arrangements are not immediately made, inform your supervisor.
4. If the harassment advances to the point of assault, it becomes a crime. You should immediately report the offense to the captain and your supervisor. Have your supervisor make arrangements for you to leave the vessel immediately or get yourself off of the vessel and inform your supervisor of your actions. Make sure the incident is not ignored.

Sexual assault and rape have occurred on vessels at sea. These serious offenses might be prevented if appropriate action is taken in the early stages. Never believe that the problem is trivial or that you are over-reacting. If you feel harassed, then it has gone too far. By reporting harassment, you are protecting others as well as yourself. The captain does not want trouble on his boat nor face a costly delay. If you inform them that trouble is brewing, they should take appropriate action.

15.7 Survival at Sea

15.7.1 Life saving equipment

Most people arrive in a survival situation with only the clothing they are wearing and the things in their pockets. Survival equipment is useless unless it's with you. At all times, you should have on your person clothing appropriate for the outside environment, a knife and your personal survival kit.

Regulations require vessels to carry a variety of equipment for use in emergencies. Make sure you know where the common equipment shown in Figure 15-3 is stored, and how to use it.

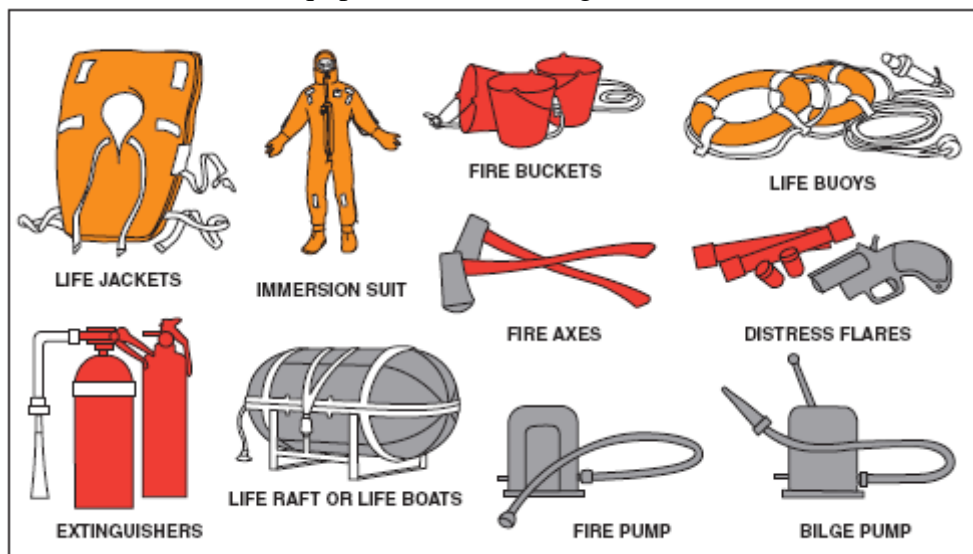

Figure 15-3 Typical life saving equipment. Image from Transport Canada (2003). Immersion suits may not be required in tropical areas.

15.7.1.1 Survival craft

Life rafts and **life boats** are both examples of survival craft (Figure 15-4). Life boats typically need to be manually deployed whereas most life rafts can either be manually deployed or will self-deploy once a vessel sinks beyond a given depth (if configured with a hydrostatic release). Life rafts should be repacked each year. The canister will have a decal with a service date. Life rafts should also be mounted in a location so it will float free if a vessel sinks (e.g., not directly under a bunch of rigging). Survival craft can be packed with varying degrees of additional survival equipment (e.g., Survival of Life at Sea (SOLAS) packs). There are three types of SOLAS packs – A, B and Coastal – and their contents vary (Table 15-1). Prior to boarding, you should be familiar with the major components of a life raft (Figure 15-5).

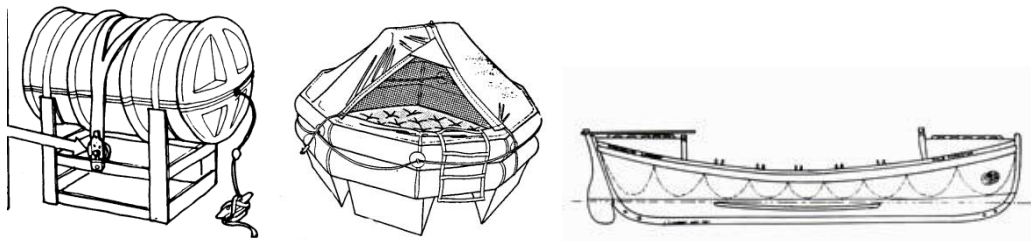

Figure 15-4 Examples of survival craft: life raft canister (left), life raft (center) and life boat (right).

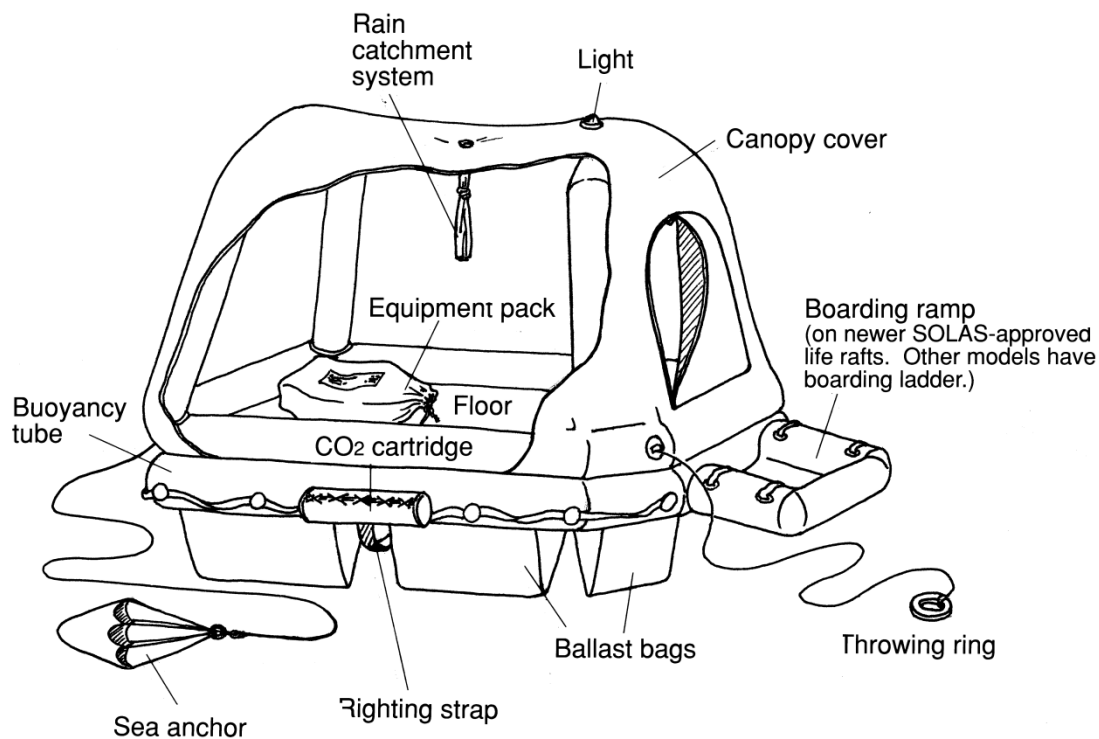
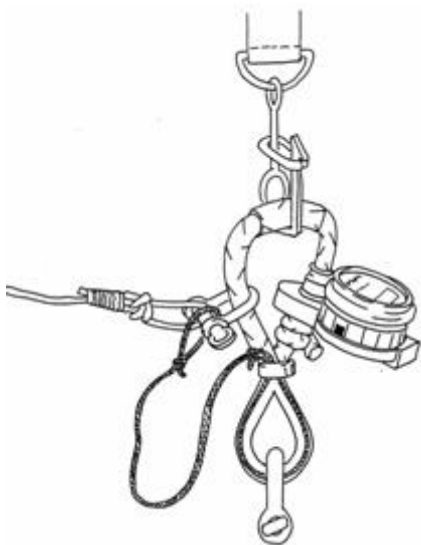

Figure 15-5 Important components of a life raft. Image courtesy of AMSEA.

Table 15-1 Comparison of SOLAS kit contents.

Equipment	Coastal pack	Solas B	Solas A
Quoit & heaving line	1	1	1

Knife	1	1	1
Bailer	1	1	1
Sponge	1	1	1
Sea anchor (drogue)	1	2	2
Paddles	2	2	2
Whistle	1	1	1
Flashlight with spare batteries & bulb	1	1	1
Signal mirror	1	1	1
Survival instructions	1	1	1
Immediate action instructions	1	1	1
Repair kit (1 set sealing clamps or plugs)	1	1	1
Pump or bellows	1	1	1
Tin openers	0	0	3
First aid kit in waterproof case	0	1	1
Rocket parachute flares	0	2	4
Hand held flares	0	3	6
Buoyant smoke signals	0	1	2
Copy of Life Saving Signals	0	1	1
Fishing tackle	0	0	1
Food ration	0	0	2,378 calories/person
Water	0	0	1.5 l/person
Rustproof, graduated drinking vessel	0	0	1
Anti-seasickness pills	0	6/person	6/person
Seasickness bag	0	1/person	1/person
Thermal protective aid	0	Enough for 10% of persons or 2, whichever is greater	Enough for 10% of persons or 2, whichever is greater



15.7.1.2 Hydrostatic release

Some, but not all, vessels may have a hydrostatic release attached to their liferaft canisters. This allows the liferaft to automatically deploy once a vessel sinks below a given depth (~4m). The basic setup includes a strong rope secured to the deck or liferaft cradle and attached to the liferaft lashing with a sliphook (aka pelican hook). There is a weak link (weaker line) that attaches the painter to the deck. If the ship sinks, the water pressure will activate a knife inside the release which cuts the rope and the liferaft will float free. As the ship sinks, the liferaft painter line will be stretched and the liferaft starts to inflate. Once the weak link breaks, survivors can board the floating liferaft.

Figure 15-6 Hydrostatic release. Image from AMSEA.



15.7.1.3 Personal flotation devices & other flotation

There is an assortment of personal flotation device (PFD) types ranging from vests to collar-like PFDs (Figure 15-7). Each type has advantages and disadvantages. The best PFD or life jacket is one that you wear and that fits properly. You should also attach a whistle and a strobe light if possible. The human voice doesn't carry well and a whistle can assist with gaining attention of rescue crew.

Tips for keeping your PFD in good condition:

- Don't put heavy objects on your PFD or use it for a kneeling pad or boat fender. PFDs lose buoyancy when crushed.
- Let your PFD drip dry thoroughly before putting it away. Always stow it in a well-ventilated place.
- Never dry your PFD on a direct heat source.
- Monitor for rips, mold, torn seams and missing reflective tape. Fix and replace as necessary.

Vessels may carry additional emergency floatation devices such as a life ring, cushion, or life sling. If you are fishing in cool water, you may also encounter immersion (survival) suits on board.

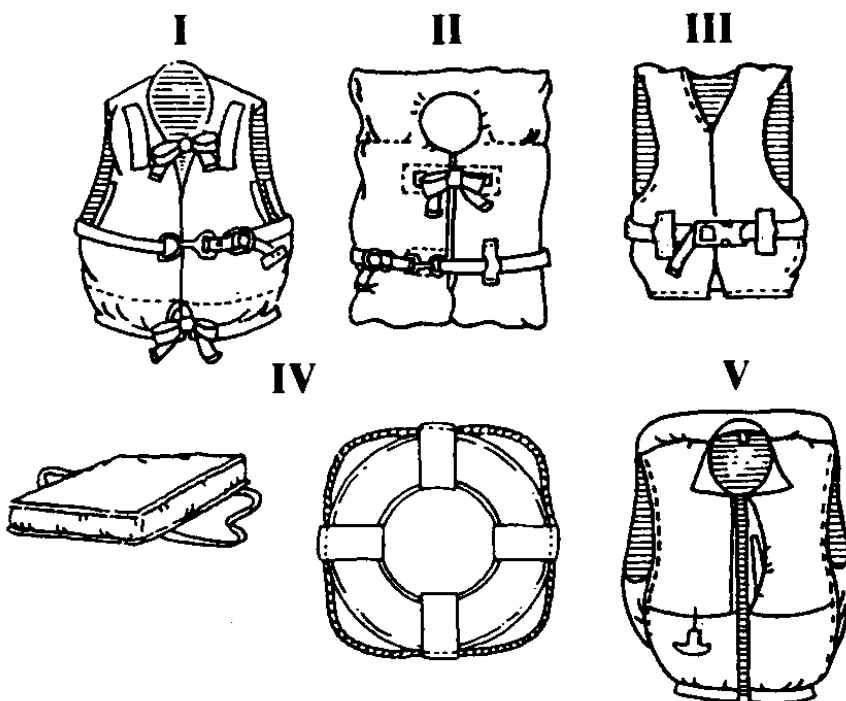



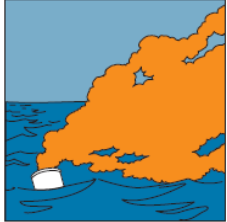

Figure 15-7 Types of PFDs (Image from <http://fwp.mt.gov/images/fishing/floatjacket.gif>).

15.7.1.4 Visual Distress Signals

Visual distress signals include pyrotechnics (or flares), flashlights, portable strobe lights, mirrors and distress flags. All have advantages and disadvantages and are only of value if used in the appropriate situation (Table 15-2).

Pyrotechnics or flares range in type and purpose. All flares should be stored in a watertight container, in a cool dry location. *Flares are valid for four years from date of manufacture*, and should be disposed of after that time. Flares get very hot – read all instructions in advance so that you are not accidentally injured in a real emergency.

Table 15-2 Advantages and disadvantages of visual distress signals (Images from (Transport Canada 2003) and California Department of Boating and Waterways).

Signal type	Use when...	Advantages	Disadvantages
Parachute signal 	<ul style="list-style-type: none"> • Day or night • You have reason to believe it will be seen from a rescue ship or from shore • You can see the mast top of a vessel on the horizon 	<ul style="list-style-type: none"> • Pistol-projected or hand-held • Long burn time (40s) • Sighted from long distance 	
Handheld flare 	<ul style="list-style-type: none"> • Day or night • You can see lights from shore or a ship or an aircraft 		<ul style="list-style-type: none"> • Fairly short sighting distance • Hot molten metal droppings
Smoke 	<ul style="list-style-type: none"> • Day only • Low or moderate wind conditions 	Hand held and floating canister format	<ul style="list-style-type: none"> • Fairly short sighting distance
Dye 	<ul style="list-style-type: none"> • Day only 		<ul style="list-style-type: none"> • Fairly short sighting distance & best from above
Lights	<ul style="list-style-type: none"> • Night only 		<ul style="list-style-type: none"> • Fairly short sighting distance
Flags 	<ul style="list-style-type: none"> • Day only 		<ul style="list-style-type: none"> • Short sighting distance
Signal mirror	<ul style="list-style-type: none"> • Day only 	<ul style="list-style-type: none"> • Can be seen for 	

		long distances	
--	--	----------------	--

15.7.1.5 Emergency Communication Equipment

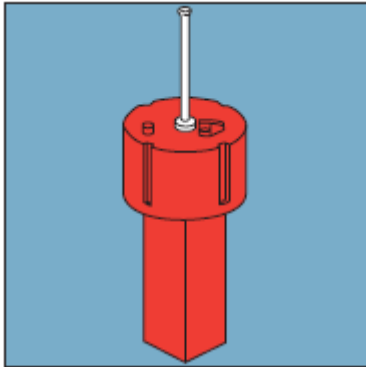

15.7.1.5.1 EPIRBs

An Emergency Position Indicating Radio Beacon (**EPIRB**; Figure 15-8) is mandatory on many vessels. Even if it is not mandatory, it is highly recommended. When activated, the battery operated EPIRB transmits a signal that is recognized as a positive indication of distress by Search and Rescue forces throughout the world. EPIRBs should be mounted in a float free position. Never attach the lanyard to the vessel. EPIRBs should be tested regularly in accordance with regulations and the manufacturer's instructions.

Figure 15-8 Examples of EPIRBs. Image from Transport Canada (2003).

15.7.1.5.2 Radios

Radio operation was discussed more fully in Chapter 3; however, everyone on board should know how to make an emergency distress call.

15.7.1.5.2.1 Distress calling procedures

Normally, the captain of the vessel will decide if and when a distress call is required. However, depending on the nature of the emergency you may be the only one able to get to the radio to make the call, therefore, you should be familiar with the procedure. Ideally, this information is posted near the radio. A distress call is used only when a life or vessel is in immediate danger. The procedure is as follows (Jensen and Dzugan 2005):

1. Make sure radio is on and select channel 16 if using a VHF radio or frequency 2182 kHz if using a SSB radio.
2. Press the transmit button and speak slowly, clearly, and calmly and say, "MAYDAY - MAYDAY - MAYDAY."
3. Say, "This is (your vessel name and call sign)" and repeat 3 times.
4. Give your present position (latitude and longitude) if you know it, or describe any navigational aids or landmarks you are near.
5. State the nature of your distress (e.g., fire, grounding, medical emergency, etc.).
6. Give the number of persons aboard and condition of any injured.
7. Describe the amount and type of survival gear on board (PFDs, liferaft, etc)
8. Briefly describe your vessel providing length, type, hull, and colors.
9. End your message by saying, "This is (vessel name and call sign) over."
10. Release the microphone and listen: Someone should answer. If you do not receive an answer, repeat the above procedure. If there is still no answer, try another channel and begin again.

If your situation permits, stand by your radio to provide information as requested (e.g., closest landmarks, water depth, etc.).

15.7.1.6 Other Equipment

Watertight and weather tight enclosures - Be sure you know the location of all watertight and weather tight closures (e.g. port holes/port lights), and how to use them. Both watertight and weather tight closures should be inspected regularly. Report any defects to the master or operator immediately. Gaskets should never be painted.

Personal survival kit - The personal survival kit must be light and small enough so it's always with you (e.g., attached to your PFD). Personal survival kit contents depend on the individual, environment and activity. However, the four essential elements of a survival kit are something to provide shelter (e.g., building aids such as string), signals, items to meet personal health needs (e.g., medications) and a fire-starter.

Comfort kit (also known as a ditch or abandon ship kit) – Includes extra items that would be “nice to have” such as extra water, extra food, additional signaling devices, Radios, flashlight, etc. The Comfort Kit should be accessible. Ideally, this would be in a float free position and be waterproof and sturdy. However, don't count on it being there when you need it; this is not a personal survival kit.

15.8 Seven Steps to Survival

The United States Coast Guard assembled the Seven Steps to Survival from the personal experiences of those who survived emergency situations. Committing the seven steps to survival to memory should be one of the goals of every observer learning how to survive at sea (Jensen and Dzugan 2005). Every time the situation changes (e.g., boarding a raft, reaching land, etc.), the seven steps begin again.

1. **Recognition** - You must quickly recognize the seriousness of the situation and that your life is in danger. Hesitation or denial may cost your life.
2. **Inventory** - Stop and assess the situation. Decide what you have that will help you survive and what are the hindrances. Inventory people including skills, injuries and mental state as well as equipment and the environment (e.g., weather, currents). Doing so will help you to make good decisions that will help you survive.
3. **Shelter** – Effective shelters provide insulation (or shade in the tropics) and protection from the elements. Clothes are your primary shelter. Shelter can also be an immersion suit, a raft, or an overturned vessel—anything that protects you against the loss (or gain) of body heat. Water can take heat away from your body much quicker than air, so shelter also helps you keep as dry as possible. High heat loss areas, including the head and neck, need to be protected most. The added buoyancy of a PFD helps to keep your head and neck out of water, therefore conserving heat. In a shore survival situation, the seven steps to survival start over again and shelter is your first priority after you inventory the situation. It takes hours to construct adequate shelter on shore and you must do so as soon as possible.
4. **Signals** - Anything that attracts attention and conveys a message is a signal. Radios, EPIRBs, and flares are signals carried by vessels. Immersion suits and PFDs sometimes have lights attached. You may have a signal mirror in your personal survival kit. If abandoning ship, anything buoyant that can be tossed overboard may help an aircraft spot your position. *Anything that makes you bigger, brighter, or different from your surroundings is a signal*, so an attempt to gather items, which float, from a sinking ship should be made. In a shore survival situation, three of anything (fires, buoys, immersions

suits on the beach) is an internationally recognized distress signal. Additional features may include hard angles and contrast to the background. Ground signals should be three times as high as wide.

5. **Water** – Water needs increase with any activity. Life rafts have limited rations of water, so it is advised to gather as much as possible before abandoning ship, if time permits. Have a strategy for gathering extra water in an emergency. In a survival situation, there are only three safe sources of water: boiled, packaged or filtered. ***Never drink seawater or urine.***
6. **Food** - A person can go without food much longer than without water. Never eat food without water—your body requires water to digest food. Life rafts are supplied with limited food rations. In a shore survival situation, many types of edibles can be found near shore. Almost any animal or green plant in the inter-tidal zone are edible, but avoid mussels or clams—they may cause paralytic shellfish poisoning.
7. **Play** - Studies have shown that mental attitude makes a positive difference in a survival situation. Play is anything that keeps you occupied and prevents your mind from dwelling on the difficulties you are facing. Play could be reading, telling jokes or stories, completing a task, improving your shelter—anything that keeps your mind active and focused.

15.9 Types of emergencies

Emergencies can be split into two types: immediate onset and delayed onset (AMSEA 2006). Immediate onset emergencies, as the name implies, happen suddenly with little or no warning. Examples include explosions, collision, capsizing, or person overboard. Delayed onset emergencies start out slowly and accumulate until the situation becomes life threatening. Regardless of whether an emergency happens quickly or is delayed, human emotions such as fear, panic and depression can be life threatening. For instance, in studies of human responses to emergencies 25% act effectively, 50% are unresponsive, and as many as 25% panic. Fear is a normal reaction in an emergency and has a useful function in keeping us aware in dangerous situations. Panic, however, prevents clear thinking, wastes energy and is an obstacle in setting priorities. Depression can also be a problem when it destroys the will to survive. There are several ways to minimize or eliminate panic, fear, and depression:

- Accept the fact that an emergency situation can happen to you
- Make contingency plans
- Acquire relevant training. It will give you procedures to follow that will increase confidence. Practice reduces panic and drills are the best way to practice.
- Recognize your ability to be creative, innovative, and resourceful in a survival situation
- Develop a positive mental attitude. Think like a survivor, not a victim!
- Do something to improve your situation.

The four primary emergencies that occur on board are person overboard, fire, flooding and abandon ship. Each will be discussed individually.

15.9.1 Person Overboard

First thing to remember is to take steps to never fall overboard by avoiding unsafe deck behavior and working on deck when it is not safe.

If you are the one overboard:

1. Attract attention, yell, whistle, etc.
2. Assume the H.E.L.P. position (Figure 15-9). The **H**eat **E**scape **L**essening **P**osition protects the critical body areas and slows down the loss of heat. If two or more people are in the water together, form a **HUDDLE** (Figure 15-9) so that the sides of your bodies are close together.
3. Keep clothes and boots on. They will increase insulation and will not pull you down.
4. Grab any floating objects that will make you more buoyant and more visible.
5. Stay as still as you can.

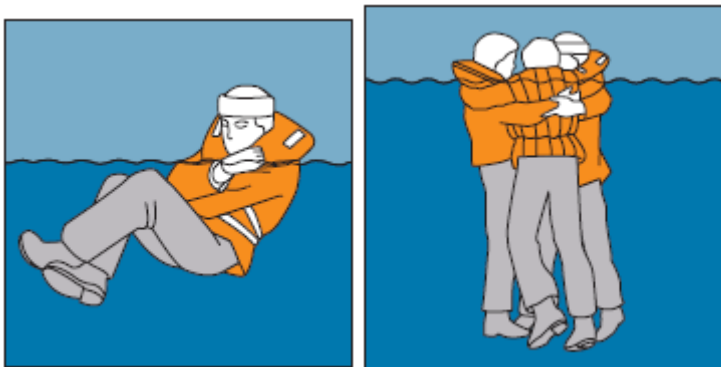

Figure 15-9 H.E.L.P. (left) and HUDDLE (right) positions. (Images from (Transport Canada 2003)).

If you are aboard a vessel and someone goes overboard:

1. Mark position with anything that floats and mark waypoint on GPS if possible. (Many vessels have a man overboard (M.O.B.) button especially for these situations)
2. Sound the alarm (typically 3 blasts for the letter “O” (morse code) repeated at least 4 times)
3. Post a lookout. Eyes and pointing hand should **never** leave victim.
4. Maneuver vessel to return to victim.
5. Rescue swimmer dons immersion suit with rescue line attached. Prepare to launch rescue craft if needed.
6. Recover victim. Bring aboard (horizontally if it takes no more time) over the side or up the stern ramp of the vessel.
7. Treat victim. Look for signs of hypothermia and hyperthermia as well as any other injuries.
8. Contact the Port Authority, Navy, Merchant Marine unit or any vessels in area if victim is not found immediately, or medical advice/attention is needed.

15.9.2 Fire

It is wise to know where fire extinguishers and exits are located in every area of the vessel—especially those areas in which you spend time. Each fire extinguisher has a small quantity of fire retardant, so back-up extinguishers should be located and brought to the fire as soon as the fire is discovered. To effectively use a fire extinguisher, fire in short bursts in a low,

sweeping motion (Figure 15-10). Keep your body low to avoid smoke inhalation and heat. Do not attempt to fight any fire alone (except a small fire e.g. a wastebasket fire).

Procedures include:

1. Sound Alarm, notify wheelhouse and signal alarm (typically 1 long continuous blast 10 seconds or more)
2. De-energize electrical system to area.
3. Close doors to stop the spread of fire and smoke.
4. Fight fire.
 - Smother, cut off air supply*
 - Cool*
 - Interrupt chain reaction*
 - Jettison*
5. Account for personnel.
6. Establish boundary perimeter.
 - Visualize area as a box*
 - Know what is on all **six** sides of the box!*
7. Prepare in case of abandon ship.
8. Ensure everyone knows how to use fire extinguishers.
 - Proper type for fire*
 - Locations*
 - Ensure extinguishers can be found in the dark*

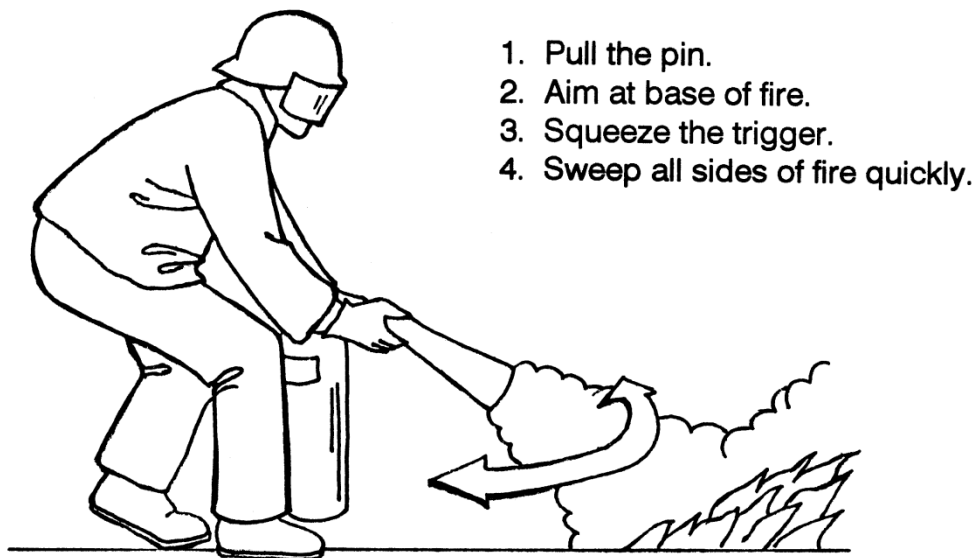

Figure 15-10 The four steps for using a fire extinguisher (P.A.S.S.). Image courtesy of AMSEA.

15.9.3 Flooding

When a vessel is taking on water, usually the crew has time to try and solve the problem. Malfunctioning pumps or leaks in through-hull fittings are not uncommon, and can usually be fixed with equipment on board. If the flooding condition worsens, pumps can sometimes be

delivered to a vessel via aircraft (area dependent). Observers have limited roles in these types of vessel emergencies but should be prepared to assist if needed.

Procedures:

1. Sound alarm (typically 1 long continuous last 10 seconds or more)
2. Close all watertight hatches, doors and air vents
3. Plug holes.
4. Use pumps and buckets of water.
5. Check lines, through-hull fittings and hull for leakage.
6. Maintain stability of vessel
7. Prepare in case of abandon ship.

Remember: **PCP -- PLUG! CLOSE! PUMP!**

15.9.4 Abandon Ship

The worst possible emergency requires a person to give up their shelter—the vessel. Never abandon the ship unless it is certain that being on board the vessel is more dangerous than being in the water. Lives have been lost because ships have been abandoned too soon during fires or flooding. Knowing the nearest exits, mustering areas, life raft locations, immersion suit locations, EPIRB locations, and the emergency equipment available become critical factors in helping you survive an abandon ship emergency.

General Abandon Ship procedures are as follows:

1. Sound Alarm (at least 7 short blasts followed by 1 long blast 10 seconds or more)
2. Send Mayday.
3. Don immersion suits/PFDs. Put on or bring extra warm clothing if possible.
4. Prepare to launch life raft. Attach painter line to vessel.
5. Assemble signal devices to take into life raft. These include EPIRBs, flares, smoke signals, flashlights, handheld radios, etc.
6. Get first aid kit, water, food, and abandon ship (survival) kit.
7. Muster at embarkation station.
8. When sinking is imminent or remaining on board is inappropriate, launch and board life raft.
9. Keep painter attached to vessel. Be prepared to cut painter immediately if there is risk to life raft or vessel sinks
10. Activate EPIRB and commence 7 Steps to Survival.

Boarding the life raft: Ideally, you will want to board the raft from the vessel without entering the water. Enter raft one at a time and assist the next person boarding.

Sometimes the life raft inflates upside down (Figure 15-11). In this case, someone will need to enter the water and follow these steps:

1. Go to side with CO₂ cartridge and orient life raft so that you are facing the wind.
2. Climb the righting strap (looks like a ladder or rope with loops) with your back arched and pull raft back.
3. You want to land on your back. If you do not clear the raft as it comes down, don't panic – either continue to pull yourself from under the raft or if you know you aren't going to clear, put a hand up as it falls to make an air space between the floor and you. Take a breath and calmly pull yourself out from under the raft.



Figure 15-11 Righting the life raft. Wind direction represented by the arrows. Image from (Transport Canada 2003).

Implement the STAY Rules for Surviving an Emergency

Stay afloat – wear your PFD at all times and stay on top of floating objects.

Stay dry – if possible stay with the vessel or board life raft directly.

Stay still – conserve heat loss.

Stay warm – get out of the water and protect the high heat loss areas.

Stay with the boat – the boat can keep you afloat and makes you easier to find.

Stay together – makes you easier to find, improves morale & if in HUDDLE position, increases warmth.

Stay sober – alcohol increases heat loss while decreasing judgment and coordination.

15.10 Psychology of Survival

Often the reason some people survive emergencies and others don't is simply the “will to live” or the “will to survive”. Maintaining a positive attitude in an emergency situation and trying to regain a sense of control over your situation is very important to survive.

Some common themes that run through the stories of survivors:

- Accept your situation, but don't give in to it.
- Act like a survivor, not like a victim.
- Don't give up.
- Be positive.
- Have a plan.
- Pray
- Play. Keep a positive attitude, and find the will to live!

15.11 Forms/Instructions

15.11.1 Safety Checklist

The Safety Checklist is in the Observer Logbook and is designed to aid in familiarizing observers with safety procedures and equipment before departing the dock for your first trip. The Safety Checklist must be completed upon boarding (Figure 15-12).

Field

Definition

Pre-Departure questions

Were you informed of the general safety procedures for the vessel? Circle Yes or No

Were alarm signals demonstrated for each type of emergency? Circle Yes or No

Did you examine escape routes from accommodations and work areas? Circle Yes or No

Where is your muster station in case of an emergency? Examples include wheelhouse, back deck, etc.

Who is the person in charge of medical treatment? E.g. captain, mate

Were you shown the location of radios and provided with instructions for use? Circle Yes or No

Were you shown the location of navigation equipment and provided with instructions for use? Circle Yes or No

Liferafts / Lifeboats

Model Record the brand and/or model of the liferaft or life boat. For each liferaft, note the capacity (# of persons the raft is rated to carry), the last inspection date, note the mounting location and whether its mounted in a position where it will float free (circle Yes or No). Is a hydrostatic release present and if present, is it attached correctly?

Was there adequate life raft capacity for all on board? Circle Yes or No

Was survival craft packed with a SOLAS kit? Circle Type A, Type B, Other or No

EPIRBs

Model Record the brand and/or model of the EPIRB. For each EPIRB, record the battery expiration date, note the mounting location, is it a category I or II model, and whether its mounted in a position where it will float free (circle Yes or No).

Station bill Check whether present or absent.

Fire extinguishers Check whether present or absent. Are fire extinguishers located in all main areas and corridors? Circle yes or no.

First aid Check whether present or absent.

equipment

High water alarm Check whether present or absent.

Watertight doors Check whether present or absent. Circle yes or no for whether they close properly (i.e., they form a seal).

Distress flares For each flare type (parachute, smoke and hand), not the number on board, whether or not they are expired, and their storage location.

Floation devices Record the number of each type (PFDs, life rings/slings and immersion suits) that are on board.

Were there adequate PFDs for all crew on board? Circle Yes or No

Drills Circle Yes or No for each type of drill (fire, man overboard, abandon ship and flooding) and not the date the drill occurred. This section is completed at the end of the trip.

Did you participate in the drills? Circle Yes or No

Other comments Provide additional comments for future observers or any other safety concerns you had on this vessel.

Safety Checklist

Pre-Departure (Complete before you leave port)						
Were you informed of the general safety procedures for the vessel?					<input checked="" type="radio"/> Yes / <input type="radio"/> No	
Were alarm signals demonstrated for each type of emergency?					<input checked="" type="radio"/> Yes / <input type="radio"/> No	
Did you examine escape routes from accommodations and work areas?					<input checked="" type="radio"/> Yes / <input type="radio"/> No	
Where is your muster station in case of an emergency?				wheelhouse		
Who is the person in charge of medical treatment?				2nd mate		
Where you shown the location of radios and provided with instructions for use?					<input checked="" type="radio"/> Yes / <input type="radio"/> No	
Where you shown the location of navigation equipment and provided with instructions on use?					<input checked="" type="radio"/> Yes / <input type="radio"/> No	
Survival craft		Capacity (persons)	Last inspection date	Location	Float free?	Hydrostatic release Present- Attach properly
Model	Yes/long 1:HD	12	01/01/09	above wheelhouse	<input checked="" type="radio"/> Y / <input type="radio"/> N	<input checked="" type="radio"/> Y / <input type="radio"/> N / <input checked="" type="radio"/> Y / <input type="radio"/> N
Model					Y / N	Y / N / Y / N
Was there adequate life raft capacity for all on board? Yes / <input checked="" type="radio"/> No						
Was survival craft packed with a SOLAS kit? A / B / <input checked="" type="radio"/> Other / No						
EPIRBs		Battery expire date	Location	Category I / II	Float free?	
Model	Ice/Marine 406	01/01/11	Crew cabin 1 - above wheelhouse	II	<input checked="" type="radio"/> Y / <input type="radio"/> N	
Model					Y / N	
Check if Present or Absent		Present	Absent			
Station bill		<input checked="" type="checkbox"/>		In main areas/corridors? <input checked="" type="radio"/> Yes / <input type="radio"/> No		
Fire extinguishers		<input checked="" type="checkbox"/>				
First aid equipment		<input checked="" type="checkbox"/>				
High water alarm		<input checked="" type="checkbox"/>				
Watertight doors		<input checked="" type="checkbox"/>		Do they close properly? Yes / <input checked="" type="radio"/> No		
Distress flares	#	Expired?	Location	Flotation devices		
Parachute	3	<input checked="" type="radio"/> Y / <input type="radio"/> N	Wheelhouse (Waterproof bins)	# Life rings / slings	2	
Smoke	5	<input checked="" type="radio"/> Y / <input type="radio"/> N	Wheelhouse (Waterproof bins)	# PFDs	10	
Hand	9	<input checked="" type="radio"/> Y / <input type="radio"/> N	Wheelhouse (Waterproof bins)	# Immersion suits	0	
		Y / N				
Were there adequate PFDs for all on board? Yes / <input checked="" type="radio"/> No						
Drills (Complete post-trip)						
	Fire	Man overboard	Abandon ship	Flooding	Other?	
Performed?	<input checked="" type="radio"/> Y / <input type="radio"/> N	<input checked="" type="radio"/> Y / <input type="radio"/> N	<input checked="" type="radio"/> Y / <input type="radio"/> N	<input checked="" type="radio"/> Y / <input type="radio"/> N		
Date (dd/mm/yy)	22/12/09	29/12/09	22/12/09	29/12/09		
Did you participate in drills? Yes / <input checked="" type="radio"/> No						
Other Comments: There was an extra engineer on board so liferaft capacity was exceeded by 1; life raft packed w/ a vessel packed kit (sounded similar to Solas B based on description; did not participate other than going to muster station for fire & flooding drills;						
Version 1.1/2009						

Figure 15-12 Example of completed Safety Checklist

16 References

- ACCSP. 2004. The Program Design of the Atlantic Coastal Cooperative Statistics Program, Second Edition.
- AFSC. 1997. North Pacific Groundfish Observer Program, Observer Sampling Manual. North Pacific Groundfish Observer Program. Fisheries Monitoring and Assessment Division, Alaska Fisheries Science Center, 7600 Sand Point Way, NE, Seattle, WA 98115. Access at: <http://www.afsc.noaa.gov/FMA/document.htm>.
- AFSC. 2007. North Pacific Groundfish Observer Program, 2007 Observer Sampling Manual. North Pacific Groundfish Observer Program. Fisheries Monitoring and Assessment Division, Alaska Fisheries Science Center, 7600 Sand Point Way, NE, Seattle, WA 98115. Access at: <http://www.afsc.noaa.gov/FMA/document.htm>.
- Agnew, D. J., J. Pearce, G. Pramod, T. Peatman, R. Watson, J. R. Beddington, and T. J. Pitcher. 2009. Estimating the Worldwide Extent of Illegal Fishing. *PLoS ONE* **4**:e4570. doi:4510.1371/journal.pone.0004570.
- Alaska Fisheries Science Center. 2007. North Pacific Groundfish Observer Manual. North Pacific Groundfish Observer Program, Seattle, WA.
- Alaska Fisheries Science Center. 2009. North Pacific Groundfish Observer Manual for 2010. North Pacific Groundfish Observer Program, Seattle, WA.
- AMSEA. 2006. Marine Safety Instructor Training Manual, 8th Edition. Alaska Marine Safety Education Association, Sitka, AK.
- Anderson, R. O., and S. J. Gutreuter. 1983. Length, Weight, and Associated Structural Indices (Chapter 15). Pages 283-300 in L. A. Nielsen and D. L. Johnson, editors. *Fisheries Techniques*. American Fisheries Society, Bethesda, MD.
- Beddington, J. R., D. J. Agnew, and C. W. Clark. 2007. Current problems in the management of marine fisheries. *Science* **316**:1713-1716.
- Ben-Yami, M. 1994. Purse Seining Manual. FAO and Fishing News Books, Oxford.
- Beverly, S. 2006. Hooks used in longline fishing. *SPC Fisheries Newsletter* **117**:45-48.
- Beverly, S. 2009. Longline terminal gear Identification guide - Draft. Submitted to the Western and Central Pacific Fisheries Commission, Scientific Committee, Fifth Regular Session, 10-21 August 2009, Port Vila, Vanuatu, WCPFC-SC5-2009/FT-IP-01, Secretariat of the Pacific Community, Marine Resources Division, Coastal Fisheries Programme, Noumea Cedex, New Caledonia.
- Bigelow, K., M. K. Musyl, F. Poission, and P. Kleiber. 2006. Pelagic longline gear depth and shoaling. *Fish. Res.* **77**:173-183.
- Bolten, A. B. 1999. Techniques for Measuring Sea Turtles. Pages 110-114 in K. L. Eckert, K. A. Bjorndal, F. A. Abreu-Grobois, and M. Donnelly, editors. *Research and Management Techniques for the Conservation of Sea Turtles*. IUCN/SSC Marine Turtle Specialist Group Publication No. 4.
- Brogan, D., S. Fukofuka, and P. Sharples. 2006. Longline Observer Guide. Secretariat of the Pacific Community Oceanic Fisheries Programme, Noumea, New Caledonia.
- CCAMLR. 2006. Scientific Observers Manual (Observation Guidelines and Reference Materials). CCAMLR, Hobart.
- Cooper, A. B. 2006. A guide to fisheries stock assessment from data to recommendations. University of New Hampshire Sea Grant College Program, Durham, NH.
- Crespi, V., and J. Prado. 2002-2009. Fishing Equipment: Square mesh window. in. FAO Fisheries and Aquaculture Department [online]. Rome. Updated 28 November 2008. <http://www.fao.org/fishery/equipment/squaremeshwindow/en>.
- Davies, S., and H. Lesch. 1998. The Commercial Sampling Programme, Grade One Observer Manual, Version 2.1 - CSP/03. Ministry of Fisheries and Marine Resources, Commercial Sampling Programme, Observer Section, Walvis Bay, Namibia.
- Davies, S. L., and J. E. Reynolds. 2002. Guidelines for developing an at-sea fishery observer programme. FAO Fish. Tech. Paper No. 414.:116 pp.
- Delgado de Molina, A., J. C. Santana, and J. Ariz. No date. Estudio de las causas del incremento de la capturas de patudo en las flotas de cerco Europeas en el Oceano Atlantico. Manual de los observadores embarcados a bordo de atuneros-cerqueros. Programa IEO / ORSTOM. Proyecto financiado por la DGXIV de la UE.
- Eayrs, S. 2007. A Guide to Bycatch Reduction in Tropical Shrimp-Trawl Fisheries. Revised edition, FAO, Rome.

- Everett, G. V. 2005-2009. Fisheries Topics: Governance, Monitoring, Control and Surveillance. *in*. FAO Fisheries and Aquaculture Department [online]. Rome. Updated 27 May 2005.
<http://www.fao.org/fishery/topic/3021/en>
- FAO. 1985. Fishery Information, Data and Information Service and Fishing Technology Service (comps). Definition and classification of fishery vessel types. FAO Fisheries Technical Paper No. 267, FAO, Rome.
- FAO. 1995. The Coordinating Working Party on Fishery Statistics: Its Origin, Role and Structure. FAO Fisheries Circular. No. 903, FAO, Rome.
- FAO. 1999. International Plan of Action for Reducing Incidental Catch of Seabirds in Longline Fisheries. International Plan of Action for the Conservation and Management of Sharks. International Plan of Action for the Management of Fishing Capacity. Food and Agriculture Organization of the United Nations, Rome.
- FAO. 2001a. International Plan of Action to prevent, deter and eliminate illegal, unreported and unregulated fishing. FAO, Rome.
- FAO. 2001b. Tropical shrimp fisheries and their impact on living resources : shrimp fisheries in Asia: Bangladesh, Indonesia and the Philippines; in the near east: Bahrain and Iran; in Africa: Cameroon, Nigeria and the United Republic of Tanzania; in Latin America: Colombia, Costa Rica, Cuba, Trinidad and Tobago, and Venezuela. FAO Fisheries Circular. No. 974, FAO, Rome.
- FAO. 2001-2009. Fishing Gear Types. Purse seines. *in*. FAO Fisheries and Aquaculture Department [online]. Rome. Updated 21 October 2008. [Cited 5 December 2009].
<http://www.fao.org/fishery/geartype/249/en>.
- FAO. 2001-2010. Basic information on Regional Fishery Bodies of the World. *in*. FAO Fisheries and Aquaculture Department [online]. Rome. Updated 22 March 2004. [Cited 9 June 2010].
<http://www.fao.org/fishery/rfb/en>.
- FAO. 2002. Report of the Expert Consultation to Review Port State Measures to Combat Illegal, Unreported and Unregulated Fishing - Rome, 4-6 November 2002. FAO Fisheries Report. No. 692, FAO, Rome.
- FAO. 2008. Report of the Expert Consultation on the Development of a Comprehensive Global Record of Fishing Vessels. Rome, 25–28 February 2008. FAO Fisheries Report No. 865, Food and Agriculture Organization, Rome.
- FAO. 2009a. Global Tuna Catches by Stock, 1950-2007. FAO Fishery Statistical Collections, Online database query December 17, 2009.
- FAO. 2009b. The State of World Fisheries and Aquaculture, 2008. FAO, Rome.
- Ferro, R. S. T., and L. Xu. 1996. An investigation of three methods of mesh size measurement. *Fisheries Research* **25**:171-190.
- Flewelling, P., C. Cullinan, D. Balton, R. P. Sautter, and J. E. Reynolds. 2002. Recent trends in monitoring, control and surveillance systems for capture fisheries. FAO Fisheries Technical Paper. No. 415, FAO, Rome.
- Fonteyne, R., G. Buglioni, I. Leonori, and F. G. O'Neill. 2007. Review of mesh measurement methodologies. *Fisheries Research* **85**:279-284.
- Gaertner, D. No date. Efficacite des senneurs thoniers et efforts reels (ESTHER). Manuel des observateurs embarques a bord des senneurs operant dans l'atlantique et dans l'océan indien. Programme de Recherches IRD / IEO. Projet financé par la DGXIV de l' U.E.
- Garibaldi, L., and S. Busilacchi, (comps.). 2009. ASFIS List of Species for Fishery Statistics Purposes. Downloaded February 2009 version from www.fao.org/fishery/collection/asis/en on 15 August 2009, FAO, Rome.
- Hanrahan, J., D. J. Melindy, and J. V. Pelrine. 1997. At-sea Observer Program Operations Manual: A Training Aid and Field Reference. National At-sea Fisheries Observer Program, Department of Fisheries and Oceans, Ottawa, Canada.
- IATTC. 1999-2005. Field Manual. Inter-American Tropical Tuna Commission, Tuna-Dolphin Program, LaJolla, CA.
- ICCAT. 2009. Compendium: Management Recommendations and Resolutions adopted by ICCAT for the Conservation of Atlantic Tunas and Tuna-like Species. International Commission for the Conservation of Atlantic Tunas, Madrid, Spain.
- ILO. 2000. Safety and Health in the Fishing Industry. Report for discussion at the Tripartite Meeting on Safety and Health in the Fishing Industry. International Labor Organization, Geneva.
- Itano, D. G. 2003. Documentation and classification of fishing gear and technology on board tuna purse seine vessels. 16th Meeting of the Standing Committee on Tuna and Billfish, Mooloolaba, Australia, 9-15 July, 2003, SCTB16 Working Paper FTWG-3.

- Itano, D. G. 2007. An examination of FAD-related gear and fishing strategies useful for data collection and FAD-based management. WCPFC-SC3-FT SWG/WP-3, Western and Central Pacific Fisheries Commission, Scientific Committee, Third Regular Session, 13-24 August, 2007, Honolulu, HI.
- IUCN. 2008. 2008 IUCN Red List of Threatened Species. www.iucnredlist.org. The World Conservation Union, Gland, Switzerland.
- Jensen, S. C., and J. Dzugan. 2005. Beating the Odds on Norther Waters: A Guide to Fishing Safety, 5th Edition. Alaska Sea Grant College Program, University of Alaska Fairbanks and Alaska Marine Safety Education Association (AMSEA), Sitka, AK.
- Kelleher, K. 2005. Discards in the world's marine fisheries: An update. FAO Fisheries Technical Paper, FAO, Rome.
- Kim, S. S., J. R. Koh, J. Y. Kim, D. Y. Moon, Y. S. Kim, S. G. Choi, T. Y. Oh, and H. S. Jo. 2005. The Korean Observer Manual for Purse Seine Fisheries. ED-2005-FR-002, National Fisheries Research and Development Institute, Ministry of Maritime Affairs and Fisheries, Busan, Republic of Korea.
- Kranz, L. 2007. Small Pelagic Fishery: Purse Seine Scientific Observer Manual. Australian Fisheries Management Authority, Canberra.
- Kuletz, K. J., E. A. Labunski, M. Renner, and D. Irons. 2008. The North Pacific Pelagic Seabird Observer Program. NPRB Project 637 Final Report, North Pacific Research Board, Anchorage, AK.
- Laubstein, K. 1999. Fisheries observers on fishing vessels. Pages 161-173 in C. P. Nolan, editor. Proceedings of the International Conference on Integrated Fisheries Monitoring, Sidney, Australia, 1-5 February 1999. FAO, Rome.
- Løkkeborg, S. 2005. Impacts of trawling and scallop dredging on benthic habitats and communities. FAO Fisheries Technical Paper No. 472, Food and Agriculture Organization, Rome.
- Longhurst, A. 1965. A survey of the fish resources of the Eastern Gulf of Guinea. J.Cons.CIEM **29**:302-334.
- Mauchline, J. 1980. Measurement of body length of *Euphausia superba* Dana. BIOMASS Handbook 4.
- McAuliffel, J. A., D. G. Itano, and S. Arceneaux. 2007. Photographic identification guide for billfish, sharks, rays, tuna-like and non-tuna finfish taken in WCPO pelagic longline fisheries (v1). Report submitted to the Western and Central Pacific Fisheries Commission, Scientific Committee, Third Regular Session, 13-24 August 2007, Honolulu, USA, WCPFC-SC3-FT SWG/IP-6.
- National Research Council Committee on Reducing Porpoise Mortality from Tuna Fishing. 1992. Dolphins and the Tuna Industry. National Academy Press, Washington D.C.
- Nedelec, C., and J. Prado. 1990. Definition and classification of fishing gear categories. FAO Fisheries Technical Paper, No. 222, Rev. 1.
- NMFS. 2007a. Northeast Fisheries Observer Program, Biological Sampling Manual. NOAA Fisheries Service, Northeast Fisheries Science Center, Woods Hole, MA.
- NMFS. 2007b. Northeast Fisheries Observer Program, Fisheries Observer Program Manual. NOAA Fisheries Service, Northeast Fisheries Science Center, Woods Hole, MA.
- NMFS. 2008a. American Samoa Observer Program Manual. Pacific Islands Regional Office, Sustainable Fisheries Division.
- NMFS. 2008b. Characterization of the US Gulf of Mexico and Southeastern Atlantic Otter Trawl and Bottom Reef Fish Fisheries - Observer Training Manual. National Marine Fisheries Service, Southeast Fisheries Science Center, Galveston Laboratory, Galveston, TX.
- NOAA Fisheries Service. 2009. Teleost Sampling Procedures, Observer Training. NOAA Fisheries Service, Panama City, FL.
- NWFSC. 2006. West Coast Groundfish Observer Manual. West Coast Groundfish Observer Program, Northwest Fisheries Science Center, Seattle, WA.
- Pauly, D. 1984. Some simple methods for the assessment of tropical fish stocks. FAO Fish. Tech. Paper 234, FAO, Rome.
- PIRO. 2009. Hawaii Longline Observer Program Observer Field Manual. Pacific Islands Regional Office, NMFS, Honolulu, HI.
- Schneider, W. 1990. FAO species identification sheets for fishery purposes. Field guide to the commercial marine resources of the Gulf of Guinea. Prepared and published with the support of the FAO Regional Office for Africa, FAO, Rome.
- SeaTurtle.org. 2008. Sea Turtle Identification Guide. *in*.
- Southeast Fisheries Science Center. 2007. Pelagic Observer Program - Observer Manual. Pelagic Observer Program, Miami, FL.
- SPC. 2007. SPC/FFA Scientific Observer forms. Secretariat of the Pacific Community and Forum Fisheries Agency.
- Transport Canada. 2003. Small Fishing Vessel - Safety Manual. TP 10038E, Transport Canada, Office of Boating Safety.

- United States Coast Guard Auxiliary. 2007. Boating Skills and Seamanship, 13th Edition. International Marine / McGraw-Hill, Camden, ME.
- Van Helvoort, G. 1986. Observer program operations manual. FAO Fisheries Technical Paper 275, FAO, Rome.
- Vendeville, P. 1990. Tropical Shrimp Fisheries: Types of fishing gears used and their selectivity. FAO Fisheries Technical Paper N°. 261 (Rev.1), FAO, Rome.
- Wallace, R. K., and K. M. Fletcher. 2000. Understanding Fisheries Management: A manual for understanding the federal fisheries management process, including analysis of the 1996 Sustainable Fisheries Act, 2nd Edition. Mississippi-Alabama Sea Grant Consortium 00-005, A publication of Auburn University and the University of Mississippi, Auburn University Marine Extension and Research Center, Mississippi-Alabama Sea Grant Legal Program and the Mississippi Law Research Institute pursuant to NOAA Award No. NA86RG0039.
- Watson, R., C. Revenga, and Y. Kura. 2006. Fishing gear associated with global marine catches I. Database development. *Fish. Res.* **79**:97-102.
- WCPFC. 2003. Draft guidelines for the rights, duties and responsibilities for observers, captains and crew. WCPFC Preparatory Conference, Fifth session, Rarotonga, Cook Islands, 29 September – 3 October 2003, WCPFC/PrepCon/WP.17.
- WCPFC. 2009. Standardised procedures for ROP observer deployment. Report submitted to the Western and Central Pacific Fisheries Commission, Regional Observer Programme, Third Intersessional Working Group, Guam, 17th – 21st March, 2009, WCPFC/ROP-IWG3/2009-010.

17 Index

A

Abandon Ship, 15-22
Acronyms, 17-72
Agency Responsibilities, 2-8

B

Backdown procedure, 9-2
Branchlines, 8-13
BRD, 7-3, 7-7
 TED, 7-8
Bycatch, 1-3
 return condition, 8-29, 11-11,
 11-24
Bycatch reduction device. *See* BRD

C

Calculations, 3-2, 17-62
Catch Composition, 5-1
Catch Composition Sampling
 pelagic longline, 8-32
 pelagic Longline, 8-28
 purse seine, 9-27
 trawl, 6-23
Catch Estimation
 trawl, 6-17
CECAF, 1-5, 17-73
chart, 3-7
CITES, 1-5, 17-70
Code of conduct, 2-12
compass, 3-7
Compliance Monitoring, 12-1
 Compliance Checklist, 12-4
Conversions, 17-62

D

Daily Activity Log, 9-9
Density sampling, 6-22
Discard
 condition, 8-29, 11-11, 11-24
 reason, 5-3, 9-25

E

EPIRB, 15-17

F

Fire, 15-20
Fishing effort
 pelagic longline, 8-21
 purse seine, 9-9, 9-22

 trawl, 6-14
Floating Object Record, 9-17
Floating objects
 FADs, 9-2
Flooding, 15-21

G

Glossary, 17-72
GPS, 3-7, 4-4

H

Harassment, 15-8
Haul Selection, 6-25
Hooks, 8-14
Hydrostatic release, 15-14

I

ICCAT, 1-5
IMO. *See* International Maritime
 Organization
International Maritime
 Organization, 4-2
International Radio Call Sign, 4-2
Invertebrates
 species codes, 17-51
IRCS. *See* International Radio Call
 Sign
IUU. *See* IUU Fishing
IUU Fishing, 13-1

J

JTED. *See* BRD

L

Length measurements
 purse seine, 9-28
Length Measurements, 10-1
 generic form, 10-21
 types, 10-22
Life saving equipment, 15-12
Living Conditions, 3-3

M

Man Overboard, 15-20
Marine debris, 14-1
Marine Mammals, 11-1, 11-6, 11-
 16
 species codes, 17-55
Maritime Mobile Service Identity,
 4-2

Mayday, 15-17
MCS, 1-1, 1-2, 1-4
MMSI. *See* Maritime Mobile
 Service Identity

N

Nautical terminology, **3-3**

O

Observer Logbook, ii, iv, 3-1, 3-2,
 3-8, 3-9, 4-1, **5-1**, 6-10, 6-14, 6-
 17, 6-18, 6-20, 6-22, 7-9, 8-26,
 8-32, 9-13, 9-27, 12-3, 12-4,
 15-3, 15-23
Observer Rights and
 Responsibilities, 2-9

P

Pelagic longline, 8-13
 fishing effort, 8-21
 gear deployment, 8-16
 gear description, 8-13, 8-17
Person Overboard, 15-20
PFD, 15-15
Purse seine, 9-1
 catch composition sampling, 9-
 27
 Daily Activity Log, 9-9
 fishing effort, 9-22
 Floating Object Record, 9-17
 gear deployment, 9-4
 gear description, 9-2, 9-5
Purse Seine, 4-7

R

Radar, 3-7, 4-4, 15-5
radio, 3-4
Radio
 emergency channel, 3-4, 3-5
Radio beacon, 3-7, 4-5
radio direction finder. *See* Radio
 beacon
Random sample table, 6-25
Random sampling, 3-8
Regulations, 12-3
Rounding, 3-2

S

Sample Bias, 3-10
Sample Type, 5-2
Sampling Priorities, 2-10

Sea Turtles, 11-1, 11-6, 11-20
species codes, 17-57
Seabirds, 11-6, 11-29
species codes, 17-58
SEAFO, 1-5
Seasickness, 15-7
Seven steps to survival, 15-18
Single Side Band, 3-4
Species codes, 17-10
Species Identification, 10-19
SSB. *See* Single Side Band

T

Tagged animals, 10-17
sea turtles, 11-22

seabirds, 11-29
Tag Encounter & Recovery
form, 10-25
tuna & billfish, 10-18
TED. *See* BRD
Total Catch Estimation
purse seine, 9-27
Trawl, 4-7
Gear deployment, 6-3
Gear description, finfish, 6-1,
6-4
Gear description, shrimp, 7-1,
7-4
Trawl doors, 6-4
Trip Summary, 4-1, 4-11

V

Vessel Hazards, 15-2
Vessel Information, 4-1
Vessel Rights and Responsibilities,
2-8
Vessel transfers, 15-4
VHF, 3-4
VMS, 4-4
Volumetric estimate
bin, 6-20
codend, 6-21

W

wedge guage, 6-7

Appendix 1. Country-Specific Information

Appendix 2. Country-Specific Contacts

Appendix 3. Country-Specific Vessel Names / Codes

Appendix 4. List of Known IUU Vessels

Last updated June 29, 2010.

CCAMLR	ICCAT	NEAFC	NAFO	Name	Previous Names	IMO Number	IRCS	Flag	Previous Flag
	x			Abdi Baba 1	Erol Bulbul	Unknown	Unknown	Bolivia	Turkey
		x	x	Alboran II	White Enterprise	7306570	4VPO	St. Kitts & Nevis	Panama
x				Aldabra		Unknown	5VAA2	Togo	
x				Amorinn	Noemi, Lome, Iceberg II	7036345	5VAN9	Togo	Belize, Togo
x				Bigaro	Lugalpesca, Hoking, Sargo	Unknown	5VBO3	Unknown	Uruguay, Togo
	x			Bigeye		Unknown	FN 003883	Unknown	
	x			Bravo		Unknown	T8AN3	Unknown	
x				Carmela	Mare, Notre Dame, Golden Sun, Gold Dragon	6803961	Unknown	Unknown	Namibia, Bolivia, Equatorial Guinea, Togo
	x			Cevahir	Salih Bayraktar	Unknown	Unknown	Bolivia	Turkey
x				Challenge	Mila, Perseverance	6622642	HO5381	Panama	UK, Equatorial Guinea
x				Chu Lim	Piscis, South Bay, Gale, Ulyses, Thor 33, Ying Peng	8713392	Unknown	Unknown	Uruguay, Equatorial Guinea, Dem. People's Rep. Korea, Togo
			x	Cliff	Ice Bay, Reefer Bay	8028424	XUVV9	Cambodia	
x				Constant	Isla Graciosa, Tropic	6607666	3CM2191	Equatorial Guinea	South Africa, Equatorial Guinea
x				Corvus	Dorita, Magnus, Thule, Eolo, Red Moon, Black Moon, Ina Maka, Galaxy	7322897	3ESP3	Panama	Uruguay, St. Vincent & Grenadines, Equatorial Guinea, Dem. People's Rep. Korea
	x			Daniaa	Carlos	Unknown	Unknown	Unknown	Guinée Rep
		x	x	Dolphin	Ognevka	8422852	UCHF	Russian Federation	Georgia
x				Draco-1	Carran, Hammer, Chilbo San 33, Liberty	9042001	XUUG8	Cambodia	Uruguay, Togo, Dem. People's Republic Korea, Panama
		x		Eros Dos	Furabolos	8604668	HO-5115	Panama	
			x	Furabolos		8604668		Unknown	

	x			Gala 1	MANARA II, ROAGAN	Unknown	Unknown	Unknown	Libya
x				Good Hope	Sea Ranger V, Toto	7020126	5NMU	Nigeria	Belize
		x	x	Gorilero	Gran Sol	6719419	9LYF36	Sierra Leone	Panama
x				Heavy Sea	Serpa Uno, Keta, Duero	7322926	3ENF8	Panama	Uruguay, Panama
		x	x	Iannis 1		7332218	H03374	Panama	
	x			Lila No. 10		Unknown	Unknown	Unknown	Panama
x				Limpopo	Lena, Alos, Ross	7388267	Unknown	Unknown	Seychelles, Ghana, Togo
	x			Madura 2		Unknown	Unknown	Unknown	
	x			Madura 3		Unknown	Unknown	Unknown	
		x	x	Maine		8707240	3XLU	Guinea Conakry	
	x			Maria		Unknown	FN 003882	Unknown	
	x			Melilla No. 101		Unknown	Unknown	Unknown	Panama
	x			Melilla No. 103		Unknown	Unknown	Unknown	Panama
		x	x	Murtosa		7385174	ZDBLI	Togo	
		x	x	Nemanskiy		8721595	Unknown	Unknown	
			x	Nicolay Chudotvoretz	Santa Nikolas	8421937	UDIB	Russian Federation	Honduras
	x			No 2 Choyo		Unknown	Unknown	Unknown	Honduras
	x			No. 101 Gloria	Golden Lake	Unknown	Unknown	Unknown	Panama
x				North Ocean	Boston, Boston-1, Jian Yuan	9230658	BZZW5	China	Bolivia, Russia, Georgia
	x			Ocean Diamond		Unknown	Unknown	Unknown	
	x			Oriente No. 7		Unknown	Unknown	Unknown	Honduras
		x	x	Red	Kabou	6706084	3EJ13	Panama	Guinea Conakry
x				Rex	Cisne Azul, Viking, Inca, Condor	6818930	Unknown	Unknown	Belize, Seychelles, Togo
	x			Sharon 1	Manara I, Poseidon	Unknown	Unknown	Unknown	Libya
	x			Southern Star 136		Unknown	Unknown	Unknown	St. Vincent and Grenadines
		x	x	Sunny Jane		7347407	V3KG2	Unknown	Belize
x				Trosky	Paloma V	9319856	Unknown	Cambodia	Uruguay, Namibia
x				Typhoon-1	Arctic Ranger, Rubin	6905408	5VTN6	Togo	UK, Seychelles
x				West Ocean	Darwin, Darwin-1, Kiev	9230672	BZTX8	China	Bolivia, Russia, Georgia
		x	x	Yucatan Basin	Enxembre, Fonte Nova, Jawhara	7321374	3EGV5	Panama	Morocco
x				Zeus	Kinsho Maru, No.18, Triton-1	9037537	Unknown	Unknown	Japan, Sierra Leone, Togo

Appendix 5. Country & IRCS Codes

FAO ISO list of 3-letter country codes (<http://www.fao.org/countryprofiles/iso3list.asp>) and International Radio Call Sign prefixes (<http://www.smeter.net/stations/call-prefixes-by-country.php>) issued to each country.

Country or Organization	Coun-try Code	Call Sign Series	Country or Organization	Coun-try Code	Call Sign Series	Country or Organization	Coun-try Code	Call Sign Series	
Afghanistan	AFG	T6A-T6Z	Central African Republic	CAF	TLA-TLZ	France	FRA	FAA-FZZ	
Albania	ALB	YAA-YAZ	Chad	TCD	TTA-TTZ			HWA-HYZ	
Algeria	DZA	7RA-7RZ	Chile	CHL	CAA-CEZ			THA-THZ	
Andorra	AND	7TA-7YZ	China	CHN	XQA-XRZ			TKA-TKZ	
Angola	AGO	C3A-C3Z			3GA-3GZ			TMA-TMZ	
Antigua and Barbuda	ATG	D2A-D3Z	Colombia	COL	BAA-BZZ			TOA-TQZ	
Argentine Republic	ARG	V2A-V2Z			3HA-3UZ			Gabonese Republic	GAB
		AYA-AZZ	HJA-HKZ	Gambia	GMB			C5A-C5Z	
		LOA-LWZ	5JA-5KZ	Georgia	GEO			4LA-4LZ	
Armenia	ARM	L2A-L9Z	Comoros	COM	D6A-D6Z			Germany	DEU
Australia	AUS	EKA-EKZ	Congo (DRC)	COD	90A-9TZ	Ghana	GHA	DAA-DRZ	
		AXA-AXZ	Congo	COG	TNA-TNZ	Greece	GRC	9GA-9GZ	
		VHA-VNZ	Cook Islands	COK	E5A-E5Z	Grenada	GRD	J4A-J4Z	
VZA-VZZ	Costa Rica	CRI	TEA-TEZ	SVA-SZZ					
Austria	AUT	OEA-OEZ	Côte d'Ivoire	CIV	TIA-TIZ	Guatemala	GTM	J3A-J3Z	
Azerbaijani Republic	AZE	4JA-4KZ	Croatia	HRV	TUA-TUZ			TDA-TDZ	
Bahamas	BHS	C6A-C6Z	Cuba	CUB	9AA-9AZ	Guinea	GIN	TGA-TGZ	
Bahrain	BHR	A9A-A9Z	Cyprus	CYP	CLA-CMZ	Guinea-Bissau	GNB	3XA-3XZ	
Bangladesh	BGD	S2A-S3Z			COA-COZ	Guyana	GUY	J5A-J5Z	
Barbados	BRB	8PA-8PZ	Czech Republic	CZE	T4A-T4Z	Haiti	HTI	8RA-8RZ	
Belarus	BLR	EUA-EWZ			C4A-C4Z	Honduras	HND	HHA-HHZ	
Belgium	BEL	ONA-OTZ			H2A-H2Z	Hong Kong	HKG	4VA-4VZ	
Belize	BLZ	V3A-V3Z	Denmark	DNK	P3A-P3Z	Hungary	HUN	HQA-HRZ	
Benin	BEN	TYA-TYZ			5BA-5BZ	Iceland	ISL	VRA-VRZ	
Bhutan	BTN	A5A-A5Z	Djibouti	DJI	OKA-OLZ	India	IND	HAA-HAZ	
Bolivia	BOL	CPA-CPZ	Dominica	DMA	OUA-OZZ	Indonesia	IDN	HGA-HGZ	
Bosnia and Herzegovina	BIH	T9A-T9Z	Dominican Republic	DOM	XPA-XPZ	International Civil Aviation Organization		TFA-TFZ	
Botswana	BWA	A2A-A2Z	Ecuador	ECU	5PA-5QZ			ATA-AWZ	
Brazil	BRA	80A-8OZ	Egypt	EGY	J2A-J2Z			ATA-AWZ	
		PPA-PYZ	El Salvador	SLV	J7A-J7Z	IND	VTA-VWZ		
Brunei Darussalam	BRN	V8A-V8Z	Ethiopia	ETH	HIA-HIZ	8TA-8YZ			
Bulgaria	BGR	LZA-LZZ	Fiji	FJI	HCA-HDZ	JZA-JZZ			
Burkina Faso	BFA	XTA-XTZ	Finland	FIN	HSA-HSZ	PKA-POZ			
Burundi	BDI	9UA-9UZ	France	FRA	HCA-HDZ	YBA-YHZ			
Cambodia	KHM	XUA-XUZ	France	FRA	SSA-SSM	7AA-7IZ			
		TJA-TJZ	France	FRA	SUA-SUZ	8AA-8IZ			
Cameroon	CMR	CFA-CKZ	France	FRA	6AA-6BZ	4YA-4YZ			
Canada	CAN	CYA-CZZ	France	FRA	HUA-HUZ	Iran	IRN	EPA-EQZ	
		VAA-VGZ	France	FRA	YSA-YSZ			9BA-9DZ	
		VOA-VOZ	France	FRA	3CA-3CZ			HNA-HNZ	
		VXA-VYZ	France	FRA	E3A-E3Z			YIA-YIZ	
		XJA-XOZ	France	FRA	ESA-ESZ			EIA-EJZ	
Cape Verde	CPV	D4A-D4Z	France	FRA	ETA-ETZ	Ireland	IRL	4XA-4XZ	
Jamaica	JAM	6YA-6YZ	France	FRA	9EA-9FZ	Israel	ISR	4ZA-4ZZ	
Japan	JPN	JAA-JSZ	France	FRA	3DN-3DZ	Italy	ITA	1AA-1ZZ	
		JAA-JSZ	France	FRA	OFA-OJZ	Romania	ROU	YOA-YRZ	
		8JA-8NZ	France	FRA	V6A-V6Z	Russian Federation	RUS	RAA-RZZ	
Jordan	JOR	JYA-JYZ	France	FRA	ERA-ERZ	Rwandese Republic	RWA	9XA-9XZ	
Kazakhstan	KAZ	UNA-UQZ	France	FRA	3AA-3AZ	Saint Kitts and Nevis	KNA	V4A-V4Z	
		5YA-5ZZ	France	FRA	JTA-JVZ	Saint Lucia	LCA	J6A-J6Z	
Kenya	KEN	5YA-5ZZ	France	FRA	CNA-CNZ	Saint Vincent and the Grenadines	VCT	J8A-J8Z	
Kiribati	KIR	T3A-T3Z	France	FRA	5CA-5GZ	Samoa	WSM	5WA-5WZ	
Dem People's Rep of Korea	PRK	HMA-HMZ	France	FRA	C8A-C9Z	San Marino	SMR	T7A-T7Z	
		P5A-P9Z	France	FRA	XYA-XZZ	Sao Tome and Principe	STP	S9A-S9Z	
Republic of Korea	KOR	DSA-DTZ	France	FRA	V5A-V5Z	Saudi Arabia	SAU	HZA-HZZ	
		D7A-D9Z	France	FRA	NPL			9NA-9NZ	
		HLA-HLZ	France	FRA	NLD	PAA-PIZ	Senegal	SEN	7ZA-7ZZ
		6KA-6NZ	France	FRA	ABW	P4A-P4Z			8ZA-8ZZ
			France	FRA	ANT	PJA-PJZ	6VA-6WZ		

Country or Organization	Coun-try Code	Call Sign Series	Country or Organization	Coun-try Code	Call Sign Series	Country or Organization	Coun-try Code	Call Sign Series		
Kuwait	KWT	9KA-9KZ	New Zealand	NZL	ZKA-ZMZ	Serbia & Montenegro	SRB & MNE	YTA-YUZ		
Kyrgyz Republic	KGZ	EXA-EXZ	Nicaragua	NIC	HTA-HTZ					YZA-YZZ
Laos	LAO	XWA-XWZ			H6A-H7Z				4NA-4OZ	
Latvia	LVA	YLA-YLZ			YNA-YNZ		Seychelles	SYC	S7A-S7Z	
Lebanon	LBN	ODA-ODZ	Niger	NER	5UA-5UZ	Sierra Leone	SLE	9LA-9LZ		
Lesotho	LSO	7PA-7PZ	Nigeria	NGA	5NA-5OZ	Singapore	SGP	S6A-S6Z		
Liberia	LBR	A8A-A8Z	Norway	NOR	JWA-JXZ					9VA-9VZ
		D5A-D5Z			LAA-LNZ	Slovak Republic	SVK	OMA-OMZ		
		ELA-ELZ			3YA-3YZ	Slovenia	SVN	S5A-S5Z		
		5LA-5MZ	Oman	OMN	A4A-A4Z	Solomon Islands	SLB	H4A-H4Z		
		6ZA-6ZZ	Pakistan	PAK	APA-ASZ	Somali Democratic Republic	SOM	T5A-T5Z		
Libya	LBY	5AA-5AZ			6PA-6SZ			60A-6OZ		
Lithuania	LTU	LYA-LYZ	Palau	PLW	T8A-T8Z	South Africa	ZAF	S8A-S8Z		
Luxembourg	LUX	LXA-LXZ	Palestinian Authority		E4A-E4Z				ZRA-ZUZ	
Macedonia Former Yugoslav	MKD	Z3A-Z3Z	Panama	PAN	HOA-HPZ	Spain	ESP	AMA-AOZ		
Madagascar	MDG	5RA-5SZ			H3A-H3Z					EAA-EHZ
Malawi	MWI	7QA-7QZ			H8A-H9Z	Sri Lanka	LKA	4PA-4SZ		
Malaysia	MYS	9MA-9MZ			3EA-3FZ	Sudan	SDN	SSN-STZ		
Maldives	MDV	8QA-8QZ			P2A-P2Z	Suriname	SUR	PZA-PZZ		
Mali	MLI	TZA-TZZ	Papua New Guinea	PNG	OAA-OCZ	Swaziland	SWZ	3DA-3DM		
Malta	MLT	9HA-9HZ	Paraguay	PRY	4TA-4TZ	Sweden	SWE	SAA-SMZ		
Marshall Islands	MHL	V7A-V7Z	Peru	PER	DUA-DZZ				7SA-7SZ	
Mauritania	MRT	5TA-5TZ	Philippines	PHL	4DA-4IZ	Switzerland	CHE	8SA-8SZ		
Mauritius	MUS	3BA-3BZ	Poland	POL	HFA-HFZ				HBA-HBZ	
Mexico	MEX	XAA-XIZ	Portugal	PRT	SNA-SRZ	Syrian Arab Republic	SYR	HEA-HEZ		
		4AA-4CZ			3ZA-3ZZ				YKA-YKZ	
		6DA-6JZ	Qatar	QAT	A7A-A7Z	Tajikistan	TJK	EYA-EYZ		
Tanzania	TZA	5HA-5IZ	United Arab Emirates	ARE	A6A-A6Z	Uruguay	URY	CVA-CXZ		
Thailand	THA	E2A-E2Z	United Kingdom of Great Britain and Northern Ireland	GBR	GAA-GZZ	Uzbekistan	UZB	UJA-UMZ		
		HSA-HSZ			MAA-MZZ	Vanuatu	VUT	YJA-YJZ		
Timor - Leste	TLS	4WA-4WZ			VPA-VQZ	Vatican City State		HVA-HVZ		
Togolese Republic	TGO	5VA-5VZ			VSA-VSZ	Venezuela	VEN	YVA-YYZ		
Tonga	TON	A3A-A3Z			ZBA-ZJZ	Viet Nam	VNM	4MA-4MZ		
Trinidad and Tobago	TTO	9YA-9ZZ			ZNA-ZOZ				XVA-XVZ	
Tunisia	TUN	TSA-TSZ			ZQA-ZQZ	2AA-2ZZ	World Meteorological Organization		3WA-3WZ	
		3VA-3VZ			United Nations		4UA-4UZ	Yemen	YEM	70A-7OZ
Turkey	TUR	TAA-TCZ			United States of America	USA	AAA-ALZ	Zambia	ZMB	9IA-9JZ
Turkmenistan	TKM	EZA-EZZ			NAA-NZZ		Zimbabwe	ZWE	Z2A-Z2Z	
Tuvalu	TUV	T2A-T2Z	WAA-WZZ							
Uganda	UGA	5XA-5XZ	KAA-KZZ							
Ukraine	UKR	EMA-EOZ								
		URA-UZZ								

Appendix 6. Fishing Gear Codes

Full list of International Standard Statistical Classification Of Fishing Gear (ISSCFG; 29 July 1980) codes (FAO 1995).

Gear Categories	Standard Abbreviation	ISSCFG
SURROUNDING NETS		01.0.0
With purse lines (purse seines)	PS	01.1.0
- one boat operated purse seines	PS1	01.1.1
- two boats operated purse seines	PS2	01.1.2
Without purse lines (lampara)	LA	01.2.0
SEINE NETS		02.0.0
Beach seines	SB	02.1.0
Boat or vessel seines	SV	02.2.0
- Danish seines	SDN	02.2.1
- Scottish seines	SSC	02.2.2
- pair seines	SPR	02.2.3
Seine nets (not specified)	SX	02.9.0
TRAWLS		03.0.0
Bottom trawls		03.1.0
- beam trawls	TBB	03.1.1
- otter trawls ¹	OTB/OTM	03.1.2
- pair trawls	PTB	03.1.3
- nephrops trawls	TBN	03.1.4
- shrimp trawls	TBS	03.1.5
- bottom trawls (not specified)	TB	03.1.9
Midwater trawls		03.2.0
- otter trawls ¹	OTM	03.2.1
- pair trawls	PTM	03.2.2
- shrimp trawls	TMS	03.2.3
- midwater trawls (not specified)	TM	03.2.9
Otter twin trawls	OTT	03.3.0
Otter trawls (not specified)	OT	03.4.9
Pair trawls (not specified)	PT	03.5.9
Other trawls (not specified)	TX	03.9.0
DREDGES		04.0.0
Boat dredges	DRB	04.1.0
Hand dredges	DRH	04.2.0
LIFT NETS		05.0.0
Portable lift nets	LNP	05.1.0
Boat-operated lift nets	LNB	05.2.0
Shore-operated stationary lift nets	LNS	05.3.0
Lift nets (not specified)	LN	05.9.0

Gear Categories	Standard Abbreviation	ISSCFG
FALLING GEAR		06.0.0
Cast nets	FCN	06.1.0
Falling gear (not specified)	FG	06.9.0
GILLNETS AND ENTANGLING NETS		07.0.0
Set gillnets (anchored)	GNS	07.1.0
Driftnets	GND	07.2.0
Encircling gillnets	GNC	07.3.0
Fixed gillnets (on stakes)	GNF	07.4.0
Trammel nets	GTR	07.5.0
Combined gillnets-trammel nets	GTN	07.6.0
Gillnets and entangling nets (not specified)	GEN	07.9.0
Gillnets (not specified)	GN	07.9.1
TRAPS		08.0.0
Stationary uncovered pound nets	FPN	08.1.0
Pots	FPO	08.2.0
Fyke nets	FYK	08.3.0
Stow nets	FSN	08.4.0
Barriers, fences, weirs, etc.	FWR	08.5.0
Aerial traps	FAR	08.6.0
Traps (not specified)	FIX	08.9.0
HOOKS AND LINES		09.0.0
Handlines and pole-lines (hand-operated) ²	LHP	09.1.0
Handlines and pole-lines (mechanized) ²	LHM	09.2.0
Set longlines	LLS	09.3.0
Drifting longlines	LLD	09.4.0
Longlines (not specified)	LL	09.5.0
Trolling lines	LTL	09.6.0
Hooks and lines (not specified) ³	LX	09.9.0
GRAPPLING AND WOUNDING		10.0.0
Harpoons	HAR	10.1.0
HARVESTING MACHINES		11.0.0
Pumps	HMP	11.1.0
Mechanized dredges	HMD	11.2.0
Harvesting machines (not specified)	HMX	11.9.0
MISCELLANEOUS GEAR⁴	MIS	20.0.0
RECREATIONAL FISHING GEAR	RG	25.0.0
GEAR NOT KNOWN OR NOT SPECIFIED	NK	99.9.0

¹ Fishery agencies may indicate side and stern bottom, and side and stern midwater trawls, as OTB-1 and OTB-2, and OTM-1 and OTM-2, respectively; ² Including jigging lines; ³ Code LDV for dory-operated line gears will be maintained for historical data purposes; ⁴ This item includes: hand and landing nets, drive-in-nets, gathering by hand with simple hand implements with or without diving equipment, poisons and explosives, trained animals, electrical fishing

Appendix 7. Species Names and Codes

The species are sorted by generalized group name (e.g., bony vs. cartilaginous fish), then order, family and scientific name. Species may be listed multiple times for cross-referencing. There are separate tables for fish (including sharks and rays), invertebrates (includes plants and rubbish), marine mammals, marine reptiles and sea birds. Source: (Garibaldi and Busilacchi 2009). Nei, nca and nep = unidentified or unclassified. If code is blank, leave the code blank on your forms but record the species name.

Fish (bony & cartilaginous)

CODE	Scientific_name	English_name	French_name	Spanish_name	Family	Order
SUR	Acanthuridae	Surgeonfishes nei	Chirurgiens nca	Navajones nep	Acanthuridae	ACANTHUROIDEI
AQH	Acanthurus chirurgus	Doctorfish			Acanthuridae	ACANTHUROIDEI
MDO	Acanthurus monroviae	Monrovia doctorfish	Chirurgien chas-chas	Navajón caniveta	Acanthuridae	ACANTHUROIDEI
NUF	Prionurus biafraensis	Biafra doctorfish			Acanthuridae	ACANTHUROIDEI
HRL	Chaetodipterus lippei	West African spadefish			Ephippidae	ACANTHUROIDEI
SPA	Ephippidae	Spadefishes nei	Chèvres, disques nca	Pagualas nep	Ephippidae	ACANTHUROIDEI
HUO	Ephippus goreensis	East Atlantic African spadefish			Ephippidae	ACANTHUROIDEI
BOF	Albula vulpes	Bonefish	Banane de mer	Macabí	Albulidae	ALBULIFORMES
ALU	Albulidae	Bonefishes nei	Albulidés nca	Macabíes nep	Albulidae	ALBULIFORMES
BNF	Pterothrissus belloci	Longfin bonefish	Banane gisu	Macabí badejo	Albulidae	ALBULIFORMES
	Chlopsis olokun				Chlopsidae	ANGUILLIFORMES
	Coloconger cadenati				Colocongridae	ANGUILLIFORMES
	Ariosoma anele	Longtrunk conger			Congridae	ANGUILLIFORMES
ARB	Ariosoma balearicum	Bandtooth conger			Congridae	ANGUILLIFORMES
CBV	Bathydroconger vicinus	Large-toothed conger			Congridae	ANGUILLIFORMES
COE	Conger conger	European conger	Congre d'Europe	Congrio común	Congridae	ANGUILLIFORMES
COS	Conger orbignyanus	Argentine conger	Congre argentin	Congrio argentino	Congridae	ANGUILLIFORMES
CGZ	Conger spp	Conger eels nei	Congres nca	Congrios nep	Congridae	ANGUILLIFORMES
COX	Congridae	Conger eels, etc. nei	Congres, etc. nca	Congrios, etc. nep	Congridae	ANGUILLIFORMES
ACL	Heteroconger	Brown garden eel			Congridae	ANGUILLIFORMES

	longissimus					
ACJ	Japonoconger africanus				Congridae	ANGUILLIFORMES
	Paraconger notialis	Guinean conger			Congridae	ANGUILLIFORMES
RCH	Rhechias bertini				Congridae	ANGUILLIFORMES
	Uroconger syringinus	Threadtail conger			Congridae	ANGUILLIFORMES
AHP	Panturichthys isognathus				Heterenchelyidae	ANGUILLIFORMES
	Panturichthys longus				Heterenchelyidae	ANGUILLIFORMES
	Panturichthys mauritanicus	Mauritanian shortface eel			Heterenchelyidae	ANGUILLIFORMES
	Pythonichthys macrurus				Heterenchelyidae	ANGUILLIFORMES
	Pythonichthys microphthalmus				Heterenchelyidae	ANGUILLIFORMES
GPC	Cynoponticus ferox	Guinean pike conger	Murénésoce de Guinée	Morenocio de Guinea	Muraenesocidae	ANGUILLIFORMES
AMP	Echidna peli	Pebbletooth moray			Muraenidae	ANGUILLIFORMES
	Enchelycore nigricans	Mulatto conger			Muraenidae	ANGUILLIFORMES
	Gymnothorax afer	Dark moray			Muraenidae	ANGUILLIFORMES
	Gymnothorax mareei	Spotjaw moray			Muraenidae	ANGUILLIFORMES
MMH	Muraena helena	Mediterranean moray			Muraenidae	ANGUILLIFORMES
MME	Muraena melanotis	Honeycomb moray			Muraenidae	ANGUILLIFORMES
MMO	Muraena robusta	Stout moray			Muraenidae	ANGUILLIFORMES
MUI	Muraenidae	Morays	Murènes	Morenas	Muraenidae	ANGUILLIFORMES
	Uropterygius wheeleri				Muraenidae	ANGUILLIFORMES
AMC	Myroconger compressus	Red eel			Myrocongridae	ANGUILLIFORMES
ANV	Avocettina infans	Avocet snipe eel			Nemichthyidae	ANGUILLIFORMES
ANU	Nemichthys curvirostris	Boxer snipe eel			Nemichthyidae	ANGUILLIFORMES
ANM	Nemichthys scolopaceus	Slender snipe eel			Nemichthyidae	ANGUILLIFORMES
	Facciolella oxyrhyncha	Facciola's sorcerer			Nettastomatidae	ANGUILLIFORMES
	Hoplunnis punctata				Nettastomatidae	ANGUILLIFORMES
NVP	Venefica proboscidea	Whipsnout sorcerer			Nettastomatidae	ANGUILLIFORMES

	<i>Apterichtus gracilis</i>				Ophichthidae	ANGUILLIFORMES
	<i>Apterichtus monodi</i>				Ophichthidae	ANGUILLIFORMES
	<i>Bascanichthys ceciliae</i>				Ophichthidae	ANGUILLIFORMES
	<i>Brachysomophis atlanticus</i>				Ophichthidae	ANGUILLIFORMES
	<i>Callechelys guineensis</i>	Shorttail snake eel			Ophichthidae	ANGUILLIFORMES
	<i>Callechelys leucoptera</i>				Ophichthidae	ANGUILLIFORMES
	<i>Dalophis boulengeri</i>				Ophichthidae	ANGUILLIFORMES
	<i>Dalophis cephalopeltis</i>				Ophichthidae	ANGUILLIFORMES
	<i>Dalophis multidentatus</i>				Ophichthidae	ANGUILLIFORMES
AOD	<i>Dalophis obtusirostris</i>				Ophichthidae	ANGUILLIFORMES
AOM	<i>Echelus myrus</i>	Painted eel			Ophichthidae	ANGUILLIFORMES
	<i>Echelus pachyrhynchus</i>				Ophichthidae	ANGUILLIFORMES
	<i>Echiophis creutzbergi</i>	Spoon-nose eel			Ophichthidae	ANGUILLIFORMES
	<i>Ethadophis epinepheli</i>				Ophichthidae	ANGUILLIFORMES
AOH	<i>Hemerorhinus opici</i>				Ophichthidae	ANGUILLIFORMES
	<i>Myrichthys pardalis</i>	Leopard eel			Ophichthidae	ANGUILLIFORMES
	<i>Myrophis plumbeus</i>	Leaden worm eel			Ophichthidae	ANGUILLIFORMES
	<i>Mystriophis crosnieri</i>				Ophichthidae	ANGUILLIFORMES
	<i>Mystriophis rostellatus</i>	African spoon-nose eel			Ophichthidae	ANGUILLIFORMES
OWX	Ophichthidae	Snake eels nei	Serpentons nca	Tiesos, serpentones nep	Ophichthidae	ANGUILLIFORMES
	<i>Ophichthus ophis</i>	Spotted snake eel			Ophichthidae	ANGUILLIFORMES
	<i>Ophichthus regius</i>	Ornate Snake Eel			Ophichthidae	ANGUILLIFORMES
OOS	<i>Ophisurus serpens</i>	Serpent eel			Ophichthidae	ANGUILLIFORMES
	<i>Pisodonophis semicinctus</i>				Ophichthidae	ANGUILLIFORMES
OPS	<i>Pseudomyrophis atlanticus</i>				Ophichthidae	ANGUILLIFORMES
ASB	<i>Serrivomer beani</i>	Bean's sawtooth eel			Serrivomeridae	ANGUILLIFORMES
AWK	<i>Serrivomer spp</i>	Sawtooth eels nei			Serrivomeridae	ANGUILLIFORMES
	<i>Dysomma brevirostre</i>	Pignosed arrowtooth			Synaphobranchid	ANGUILLIFORMES

		eel			ae	
SVY	Synaphobranchidae	Cutthroat eels nei			Synaphobranchid ae	ANGUILLIFORMES
	Synaphobranchus affinis	Grey cutthroat			Synaphobranchid ae	ANGUILLIFORMES
	Atherina lopeziana				Atherinidae	ATHERINIFORMES
	Aulopus cadenati	Guinean flagfin			Aulopidae	AULOPIFORMES
ULF	Aulopus filamentosus	Royal flagfin			Aulopidae	AULOPIFORMES
	Chlorophthalmus agassizi	Shortnose greeneye			Chlorophthalmida e	AULOPIFORMES
PFS	Parasudis fraserbrunneri				Chlorophthalmida e	AULOPIFORMES
EVO	Evermannella balbo	Balbo sabretooth			Evermannellidae	AULOPIFORMES
ODM	Odontostomops normalops	Undistinguished sabretooth			Evermannellidae	AULOPIFORMES
	Bathymicrops regis				Ipnopidae	AULOPIFORMES
BDU	Bathypterois dubius	Spiderfish			Ipnopidae	AULOPIFORMES
	Bathypterois grallator	Tripodfish			Ipnopidae	AULOPIFORMES
	Bathypterois quadrifilis				Ipnopidae	AULOPIFORMES
	Bathytyphlops sewelli				Ipnopidae	AULOPIFORMES
AIY	Ahliesaurus berryi				Notosudidae	AULOPIFORMES
	Scopelosaurus argenteus	Waryfish			Notosudidae	AULOPIFORMES
	Scopelosaurus lepidus	Blackfin waryfish			Notosudidae	AULOPIFORMES
VSH	Scopelosaurus spp				Notosudidae	AULOPIFORMES
DLF	Dolichosudis fuliginosa				Paralepididae	AULOPIFORMES
	Lestidiops cadenati				Paralepididae	AULOPIFORMES
	Lestidiops sphyrenoides				Paralepididae	AULOPIFORMES
	Benthalbella infans	Zugmayer's pearleye			Scopelarchidae	AULOPIFORMES
OUA	Scopelarchus analis	Short fin pearleye			Scopelarchidae	AULOPIFORMES
BHF	Bathysaurus ferox	Deep-sea lizardfish			Synodontidae	AULOPIFORMES
	Bathysaurus mollis	Highfin lizardfish			Synodontidae	AULOPIFORMES
	Saurida brasiliensis	Brazilian lizardfish			Synodontidae	AULOPIFORMES

TCY	Trachinocephalus myops	Snakefish			Synodontidae	AULOPIFORMES
BBL	Batrachoides liberiensis	Hairy toadfish			Batrachoididae	BATRACHOIDIFORMES
TDF	Batrachoides spp	Toadfishes nei	Crapauds nca	Sapos nep	Batrachoididae	BATRACHOIDIFORMES
TFD	Batrachoididae	Toadfishes, etc. nei	Crapauds, etc. nca	Sapos, etc. nep	Batrachoididae	BATRACHOIDIFORMES
BHD	Halobatrachus didactylus	Lusitanian toadfish	Crapaud-lusitanien	Sapo lusitánico	Batrachoididae	BATRACHOIDIFORMES
BPE	Perulibatrachus elminensis	Guinean toadfish			Batrachoididae	BATRACHOIDIFORMES
	Perulibatrachus rosignoli	Rosignol toadfish			Batrachoididae	BATRACHOIDIFORMES
BAF	Ablennes hians	Flat needlefish	Orphie plate	Agujón sable	Belonidae	BELONIFORMES
BEN	Belonidae	Needlefishes, etc. nei	Aiguilles, orphies nca	Agujones, maraos nep	Belonidae	BELONIFORMES
	Strongylura senegalensis	Senegal needlefish			Belonidae	BELONIFORMES
AND	Tylosurus acus	Agujon needlefish	Aiguille voyeuse	Marao ojón (=Aguja imperial)	Belonidae	BELONIFORMES
BTS	Tylosurus crocodilus crocodilus	Hound needlefish	Aiguille crocodile	Marao lisero	Belonidae	BELONIFORMES
NED	Tylosurus spp	Needlefishes nei	Aiguilles nca	Maraos nep	Belonidae	BELONIFORMES
	Cheilopogon cyanopterus	Margined flyingfish			Exocoetidae	BELONIFORMES
	Cheilopogon melanurus	Atlantic flyingfish			Exocoetidae	BELONIFORMES
	Cheilopogon milleri	Guinean flyingfish			Exocoetidae	BELONIFORMES
ECG	Cheilopogon nigricans	Blacksail flyingfish			Exocoetidae	BELONIFORMES
	Cheilopogon pinnatibarbatus pinnatibarbatus	Bennett's flyingfish			Exocoetidae	BELONIFORMES
FLY	Exocoetidae	Flyingfishes nei	Exocets nca	Voladores nep	Exocoetidae	BELONIFORMES
FOA	Fodiator acutus	Sharpchin flyingfish			Exocoetidae	BELONIFORMES
FFV	Hirundichthys affinis	Fourwing flyingfish	Exocet hirondelle	Volador golondrina	Exocoetidae	BELONIFORMES
PXB	Parexocoetus brachypterus	Sailfin flyingfish			Exocoetidae	BELONIFORMES
	Prognichthys	Bluntnose flyingfish			Exocoetidae	BELONIFORMES

	<i>gibbifrons</i>					
BAL	<i>Hemiramphus brasiliensis</i>	Ballyhoo halfbeak	Demi-bec brésilien	Agujeta brasileña	Hemiramphidae	BELONIFORMES
HAX	<i>Hemiramphus</i> spp	Halfbeaks nei	Demi-becs nca	Agujetas nep	Hemiramphidae	BELONIFORMES
	<i>Hyporhamphus picarti</i>	African halfbeak			Hemiramphidae	BELONIFORMES
	<i>Oxyporhamphus micropterus similis</i>	False halfbeak			Hemiramphidae	BELONIFORMES
	<i>Scomberesox simulans</i>	Dwarf saury	Balaou atlantique	Paparda del Atlántico	Scomberesocidae	BELONIFORMES
SFN	<i>Diretmichthys parini</i>	Parin's spinyfish	Dirette de Parin	Malcarado de Parin	Diretmidae	BERYCIFORMES
	<i>Diretmoides pauciradiatus</i>	Longwing spinyfin	Dirette de Parin	Malcarado de Parin	Diretmidae	BERYCIFORMES
DUU	<i>Diretmus argenteus</i>	Silver spinyfin			Diretmidae	BERYCIFORMES
HCZ	Holocentridae	Squirrelfishes nei	Marignons nca	Candiles nep	Holocentridae	BERYCIFORMES
HOO	<i>Holocentrus ascensionis</i>	Squirrelfish			Holocentridae	BERYCIFORMES
	<i>Sargocentron hastatum</i>	Red squirrelfish	Marignan sabre	Candil sable	Holocentridae	BERYCIFORMES
	<i>Melamphaes leprus</i>				Melamphidae	BERYCIFORMES
PMC	<i>Poromitra crassiceps</i>	Crested bigscale			Melamphidae	BERYCIFORMES
GXW	<i>Gephyroberyx darwinii</i>	Darwin's slimehead			Trachichthyidae	BERYCIFORMES
HPR	<i>Hoplostethus mediterraneus</i>	Mediterranean slimehead	Hoplostète argenté	Reloj mediterráneo	Trachichthyidae	BERYCIFORMES
TRC	Trachichthyidae	Slimeheads nei	Poissons-montres nca	Relojes nep	Trachichthyidae	BERYCIFORMES
AEB	<i>Alestes baremoze</i>	Silversides			Alestiidae	CHARACIFORMES
AED	<i>Alestes dentex</i>	Characin			Alestiidae	CHARACIFORMES
	<i>Alestes liebrechtsii</i>				Alestiidae	CHARACIFORMES
	<i>Alestes macrophthalmus</i>	Torpedo Robber			Alestiidae	CHARACIFORMES
	<i>Distichodus antonii</i>				Citharinidae	CHARACIFORMES
	<i>Distichodus brevipinnis</i>				Citharinidae	CHARACIFORMES
	<i>Distichodus engycephalus</i>	Perch			Citharinidae	CHARACIFORMES
	<i>Distichodus fasciolatus</i>	Sharktail distichodus			Citharinidae	CHARACIFORMES

	Distichodus hypostomatus				Citharinidae	CHARACIFORMES
	Distichodus kolleri				Citharinidae	CHARACIFORMES
	Distichodus lusosso	Longsnout distichodus			Citharinidae	CHARACIFORMES
DTM	Distichodus maculatus	Spotted citharinid			Citharinidae	CHARACIFORMES
DTN	Distichodus niloticus				Citharinidae	CHARACIFORMES
	Distichodus notospilus				Citharinidae	CHARACIFORMES
	Distichodus rostratus	Grass-eaters			Citharinidae	CHARACIFORMES
DTX	Distichodus sexfasciatus	Sixbar distichodus			Citharinidae	CHARACIFORMES
DSE	Distichodus spp	Grass-eaters nei			Citharinidae	CHARACIFORMES
	Eugnathichthys macroterolepis				Citharinidae	CHARACIFORMES
	Hemigrammocharax ocellicauda				Citharinidae	CHARACIFORMES
IHB	Ichthyborus besse				Citharinidae	CHARACIFORMES
	Ichthyborus monodi				Citharinidae	CHARACIFORMES
MSO	Mesoborus crocodilus				Citharinidae	CHARACIFORMES
NNU	Nannaethiops unitaeniatus	Oneline tetra			Citharinidae	CHARACIFORMES
	Nannocharax ansorgii				Citharinidae	CHARACIFORMES
	Nannocharax fasciatus				Citharinidae	CHARACIFORMES
	Nannocharax intermedius				Citharinidae	CHARACIFORMES
	Nannocharax latifasciatus				Citharinidae	CHARACIFORMES
	Nannocharax lineomaculatus				Citharinidae	CHARACIFORMES
	Nannocharax micros				Citharinidae	CHARACIFORMES
	Nannocharax niloticus				Citharinidae	CHARACIFORMES
	Nannocharax occidentalis				Citharinidae	CHARACIFORMES
	Nannocharax reidi				Citharinidae	CHARACIFORMES
	Nannocharax				Citharinidae	CHARACIFORMES

	rubrolabiatus					
	Nannocharax usongo				Citharinidae	CHARACIFORMES
	Nannocharax zebra				Citharinidae	CHARACIFORMES
NLA	Neolebias ansorgii				Citharinidae	CHARACIFORMES
	Neolebias trewavasae				Citharinidae	CHARACIFORMES
	Neolebias unifasciatus				Citharinidae	CHARACIFORMES
PDD	Paradistichodus dimidiatus				Citharinidae	CHARACIFORMES
	Phago loricatus	African pike-characin			Citharinidae	CHARACIFORMES
XES	Xenocharax spilurus				Citharinidae	CHARACIFORMES
CLP	Clupeidae	Herrings, sardines nei	Harengs, sardines nca	Arenques, sardinas nep	Clupeidae	CLUPEIFORMES
BOA	Ethmalosa fimbriata	Bonga shad	Ethmalose d'Afrique	Sábalo africano	Clupeidae	CLUPEIFORMES
PLO	Pellonula leonensis	Smalltoothed pellonula	Spratelle de Guinée	Sardinita guineana	Clupeidae	CLUPEIFORMES
	Pellonula vorax	Bigtoothed pellonula	Spratelle de Guinée	Sardinita guineana	Clupeidae	CLUPEIFORMES
PIL	Sardina pilchardus	European pilchard(=Sardine)	Sardine commune	Sardina europea	Clupeidae	CLUPEIFORMES
SAA	Sardinella aurita	Round sardinella	Allache	Alacha	Clupeidae	CLUPEIFORMES
SAE	Sardinella maderensis	Madeiran sardinella	Grande allache	Machuelo	Clupeidae	CLUPEIFORMES
	Sardinella rouxi	Yellowtail sardinella	Sardinelle miyako	Sardinela sinda	Clupeidae	CLUPEIFORMES
SIX	Sardinella spp	Sardinellas nei	Sardinelles nca	Sardinelas nep	Clupeidae	CLUPEIFORMES
ANX	Engraulidae	Anchovies, etc. nei	Anchois, etc. nca	Anchoas, etc. nep	Engraulidae	CLUPEIFORMES
ANE	Engraulis encrasicolus	European anchovy	Anchois	Boquerón	Engraulidae	CLUPEIFORMES
ILI	Ilisha africana	West African ilisha	Alose rasoir	Sardineta africana	Pristigasteridae	CLUPEIFORMES
CLU	Clupeoidei	Clupeoids nei	Clupéoidés nca	Clupeoideos nep		CLUPEIFORMES
CEC	Elops lacerta	West African ladyfish	Guinée d'Afrique occidentale	Malacho de Africa occidental	Elopidae	ELOPIFORMES
CEG	Elops senegalensis	Senegalese ladyfish	Guinée du Sénégal	Malacho senegalés	Elopidae	ELOPIFORMES
TAR	Megalops atlanticus	Tarpon	Tarpon argenté	Tarpón	Megalopidae	ELOPIFORMES
BMA	Bregmaceros atlanticus	Antenna codlet			Bregmacerotidae	GADIFORMES
	Bregmaceros nectabanus	Smallscale codlet			Bregmacerotidae	GADIFORMES
	Bathygadus favosus				Macrouridae	GADIFORMES

BGO	Bathygadus macrops	Bullseye grenadier			Macrouridae	GADIFORMES
BGN	Bathygadus melanobranchus	Vaillant's grenadier			Macrouridae	GADIFORMES
CKP	Cetonurus globiceps	Globehead grenadier			Macrouridae	GADIFORMES
	Coelorinchus geronimo	Hollowsnout grenadier			Macrouridae	GADIFORMES
HYS	Hymenocephalus italicus	Glasshead grenadier			Macrouridae	GADIFORMES
RTX	Macrouridae	Grenadiers, rattails nei		Granaderos, colas de ratón nep	Macrouridae	GADIFORMES
MLL	Malacocephalus laevis	Softhead grenadier			Macrouridae	GADIFORMES
MLO	Malacocephalus occidentalis	Western softhead grenadier			Macrouridae	GADIFORMES
NZA	Nezumia aequalis	Common Atlantic grenadier	Grenadier lisse	Granadero liso	Macrouridae	GADIFORMES
NZD	Nezumia duodecim	Twelve-rayed grenadier			Macrouridae	GADIFORMES
NZM	Nezumia micronychodon	Smalltooth grenadier			Macrouridae	GADIFORMES
NZS	Nezumia sclerorhynchus	Roughtip grenadier			Macrouridae	GADIFORMES
SUQ	Squalogadus modificatus	Tadpole whiptail			Macrouridae	GADIFORMES
HKB	Merluccius polli	Benguela hake	Merlu d'Afrique tropicale	Merluza de Benguela	Merlucciidae	GADIFORMES
HKM	Merluccius senegalensis	Senegalese hake	Merlu du Sénégal	Merluza del Senegal	Merlucciidae	GADIFORMES
HKX	Merluccius spp	Hakes nei	Merlus nca	Merluzas nep	Merlucciidae	GADIFORMES
LML	Laemonema laureysi	Guinean codling			Moridae	GADIFORMES
	Laemonema yarrellii				Moridae	GADIFORMES
MOR	Moridae	Moras, codlings, nei	Mores nca	Moras nep	Moridae	GADIFORMES
	Physiculus huloti				Moridae	GADIFORMES
PQO	Physiculus spp				Moridae	GADIFORMES
GAD	Gadiformes	Gadiformes nei	Gadiformes nca	Gadiformes nep		GADIFORMES
	Apletodon pellegrini	Chubby clingfish			Gobiesocidae	GOBIESOCIFORMES
	Lepadogaster	Cornish sucker			Gobiesocidae	GOBIESOCIFORMES

	purpurea					
GOC	Opeatogenys cadenati				Gobiesocidae	GOBIESOCIFORMES
	Bostrychus africanus				Eleotridae	GOBIOIDEI
	Dormitator lebretonis			Camote del Pacífico	Eleotridae	GOBIOIDEI
FGB	Eleotridae	Gudgeons, sleepers nei	Gudgeons, dormeurs nca	Durmientes nep	Eleotridae	GOBIOIDEI
	Eleotris senegalensis				Eleotridae	GOBIOIDEI
EOV	Eleotris vittata				Eleotridae	GOBIOIDEI
	Awaous lateristriga	West African freshwater goby			Gobiidae	GOBIOIDEI
EBG	Ebomegobius goodi				Gobiidae	GOBIOIDEI
GPA	Gobiidae	Gobies nei	Gobies nca	Góbidos nep	Gobiidae	GOBIOIDEI
	Gobioides africanus				Gobiidae	GOBIOIDEI
	Gobioides sagitta				Gobiidae	GOBIOIDEI
	Gobionellus occidentalis				Gobiidae	GOBIOIDEI
GCR	Gobius cruentatus	Red-mouthed goby			Gobiidae	GOBIOIDEI
GOB	Gobius spp	Atlantic gobies nei	Gobies de l'Atlantique nca	Góbidos, chaparrudos nep	Gobiidae	GOBIOIDEI
GOJ	Gorogobius nigricinctus				Gobiidae	GOBIOIDEI
	Mauligobius nigri				Gobiidae	GOBIOIDEI
NMI	Nematogobius ansorgii				Gobiidae	GOBIOIDEI
	Nematogobius maindroni				Gobiidae	GOBIOIDEI
	Periophthalmus barbarus	Atlantic mudskipper			Gobiidae	GOBIOIDEI
OGH	Porogobius schlegelii				Gobiidae	GOBIOIDEI
TGN	Thorogobius angolensis				Gobiidae	GOBIOIDEI
	Thorogobius rofeni				Gobiidae	GOBIOIDEI
WHZ	Wheelerigobius maltzani				Gobiidae	GOBIOIDEI
	Wheelerigobius wirtzi	Cameroon goby			Gobiidae	GOBIOIDEI
	Yongeichthys thomasi				Gobiidae	GOBIOIDEI

MDH	<i>Microdesmus aethiopicus</i>				Microdesmidae	GOBIOIDEI
AGA	<i>Guentherus altivela</i>	Jellynose; Highfin tadpole fish			Ateleopodidae	LAMPRIFORMES
	<i>Ijimaia loppei</i>	Loppe's tadpole fish			Ateleopodidae	LAMPRIFORMES
LAG	<i>Lampris guttatus</i>	Opah	Opah	Opa	Lampridae	LAMPRIFORMES
LRE	<i>Radiicephalus elongatus</i>	Tapertail			Radiicephalidae	LAMPRIFORMES
REL	<i>Regalecus glesne</i>	King of herrings	Roi des harengs	Rey de los arenques	Regalecidae	LAMPRIFORMES
LSC	<i>Stylephorus chordatus</i>	Tube-eye			Stylephoridae	LAMPRIFORMES
DSM	<i>Desmodema polystictum</i>	Polka-dot ribbonfish			Trachipteridae	LAMPRIFORMES
TRX	Trachipteridae	Ribbonfishes	Trachyptères, poissons-rubans	Peces cinta	Trachipteridae	LAMPRIFORMES
TRQ	<i>Trachipterus trachipterus</i>	Mediterranean dealfish; ribbonfish	Poisson ruban	Traquíptero	Trachipteridae	LAMPRIFORMES
	<i>Antennarius pardalis</i>				Antennariidae	LOPHIIFORMES
	<i>Antennarius striatus</i>	striated frogfish			Antennariidae	LOPHIIFORMES
ANF	Lophiidae	Anglerfishes nei	Baudroies, etc. nca	Rapes, etc. nep	Lophiidae	LOPHIIFORMES
	<i>Lophiodes kempfi</i>	Longspine African angler			Lophiidae	LOPHIIFORMES
ANK	<i>Lophius budegassa</i>	Blackbellied angler	Baudroie rousse	Rape negro	Lophiidae	LOPHIIFORMES
MNZ	<i>Lophius</i> spp	Monkfishes nei	Baudroies nca	Rapes nep	Lophiidae	LOPHIIFORMES
MVA	<i>Lophius vaillanti</i>	Shortspine African angler	Baudroie africaine	Rape africano	Lophiidae	LOPHIIFORMES
DBA	<i>Dibranchus atlanticus</i>	Atlantic batfish			Ogcocephalidae	LOPHIIFORMES
MLR	<i>Chelon labrosus</i>	Thicklip grey mullet			Mugilidae	MUGILIFORMES
	<i>Liza falcipinnis</i>	Sicklefin mullet			Mugilidae	MUGILIFORMES
	<i>Liza grandisquamis</i>	Largescaled mullet			Mugilidae	MUGILIFORMES
LZD	<i>Liza dumerili</i>	Grooved mullet			Mugilidae	MUGILIFORMES
LZZ	<i>Liza</i> spp				Mugilidae	MUGILIFORMES
	<i>Mugil bananensis</i>	Banana mullet	Mulet sauteur d'Afrique	Galúa africana	Mugilidae	MUGILIFORMES
MUO	<i>Mugil capurrii</i>	Leaping African mullet	Mulet sauteur d'Afrique	Galúa africana	Mugilidae	MUGILIFORMES
MUF	<i>Mugil cephalus</i>	Flathead grey mullet	Mulet à grosse tête	Pardete	Mugilidae	MUGILIFORMES

MGU	Mugil curema	White mullet	Mulet blanc	Lisa blanca	Mugilidae	MUGILIFORMES
MGS	Mugil spp				Mugilidae	MUGILIFORMES
MUL	Mugilidae	Mullets nei	Mulets nca	Lizas nep	Mugilidae	MUGILIFORMES
BHG	Benthoosema glaciale	Glacier lantern fish	Lanterne glaciaire	Linterna oscura	Myctophidae	MYCTOPHIFORMES
BNS	Benthoosema suborbitale	Smallfin lanternfish			Myctophidae	MYCTOPHIFORMES
	Bolinichthys photothorax	Spurcheek lanternfish			Myctophidae	MYCTOPHIFORMES
	Bolinichthys supralateralis	Stubby lanternfish			Myctophidae	MYCTOPHIFORMES
	Centrobranchus nigroocellatus	Roundnose lanternfish			Myctophidae	MYCTOPHIFORMES
	Ceratoscopelus warmingii	Warming's lantern fish	Lanterne de Madère	Carpintero	Myctophidae	MYCTOPHIFORMES
DPB	Diaphus bertelseni				Myctophidae	MYCTOPHIFORMES
DPY	Diaphus brachycephalus	Short-headed lantern fish			Myctophidae	MYCTOPHIFORMES
	Diaphus garmani	Garman's lanternfish			Myctophidae	MYCTOPHIFORMES
DPO	Diaphus holti	Small lantern fish	Lanterne courte	Rafino corto	Myctophidae	MYCTOPHIFORMES
DPL	Diaphus lucidus	Spotlight lanternfish			Myctophidae	MYCTOPHIFORMES
DPI	Diaphus mollis	Soft lanternfish			Myctophidae	MYCTOPHIFORMES
	Diaphus perspicillatus	Transparent lantern fish			Myctophidae	MYCTOPHIFORMES
	Diaphus splendidus	Horned lanternfish			Myctophidae	MYCTOPHIFORMES
	Diaphus taaningi				Myctophidae	MYCTOPHIFORMES
DGA	Diogenichthys atlanticus	Longfin lanternfish			Myctophidae	MYCTOPHIFORMES
ELR	Electrona risso	Electric lantern fish	Étincelle	Chispa	Myctophidae	MYCTOPHIFORMES
	Gonichthys cocco				Myctophidae	MYCTOPHIFORMES
	Hygophum reinhardtii	Reinhardt's lantern fish	Lanterne des Bermudes	Benet negro	Myctophidae	MYCTOPHIFORMES
	Hygophum taaningi		Lanterne des Bermudes	Benet negro	Myctophidae	MYCTOPHIFORMES
	Lampadena anomala				Myctophidae	MYCTOPHIFORMES
LDC	Lampadena chavesi				Myctophidae	MYCTOPHIFORMES
	Lampadena luminosa	Luminous lanternfish			Myctophidae	MYCTOPHIFORMES
LPL	Lampanyctus alatus	Winged lanternfish			Myctophidae	MYCTOPHIFORMES

	Lampanyctus nobilis	Noble lampfish			Myctophidae	MYCTOPHIFORMES
	Lampanyctus tenuiformis				Myctophidae	MYCTOPHIFORMES
	Lepidophanes guentheri				Myctophidae	MYCTOPHIFORMES
LNF	Lobianchia dofleini	Dofleini's lantern fish	Lanterne de Dofleini	Japonés	Myctophidae	MYCTOPHIFORMES
	Lobianchia gemellarii	Cocco's lantern fish	Lanterne de Dofleini	Japonés	Myctophidae	MYCTOPHIFORMES
LXX	Myctophidae	Lanternfishes nei	Lanternules nca	Peces linterna nep	Myctophidae	MYCTOPHIFORMES
	Myctophum affine	Metallic lantern fish			Myctophidae	MYCTOPHIFORMES
	Myctophum asperum	Prickly lanternfish			Myctophidae	MYCTOPHIFORMES
MCU	Myctophum nitidulum				Myctophidae	MYCTOPHIFORMES
	Myctophum obtusirostre	Bluntsnout lanternfish			Myctophidae	MYCTOPHIFORMES
MTP	Myctophum punctatum	Spotted lanternfish			Myctophidae	MYCTOPHIFORMES
LYL	Nannobranchium lineatum				Myctophidae	MYCTOPHIFORMES
NOV	Notolychnus valdiviae	Topside lampfish			Myctophidae	MYCTOPHIFORMES
	Notoscopelus caudispinosus	Lobisomem			Myctophidae	MYCTOPHIFORMES
	Notoscopelus resplendens	Patchwork lampfish			Myctophidae	MYCTOPHIFORMES
LAX	Notoscopelus spp	Patchwork lampfishes			Myctophidae	MYCTOPHIFORMES
	Taaningichthys minimus				Myctophidae	MYCTOPHIFORMES
SYJ	Scopelengys tristis	Pacific blackchin			Neoscopelidae	MYCTOPHIFORMES
	Aldrovandia gracilis				Halosauridae	NOTACANTHIFORMES
	Aldrovandia phalacra	Hawaiian halosaurid fish			Halosauridae	NOTACANTHIFORMES
NHU	Halosaurus ovenii				Halosauridae	NOTACANTHIFORMES
	Cataetyx bruuni				Bythitidae	OPHIDIIFORMES
SNB	Snyderidia canina				Carapidae	OPHIDIIFORMES
BRD	Brotula barbata	Bearded brotula	Brotule barbée	Brótula de barbas	Ophidiidae	OPHIDIIFORMES
OLB	Lamprogrammus brunswigi				Ophidiidae	OPHIDIIFORMES
	Lamprogrammus	Legless cuskeel			Ophidiidae	OPHIDIIFORMES

	exutus					
	Monomitopus metriostoma				Ophidiidae	OPHIDIIFORMES
	Monomitopus metriostoma				Ophidiidae	OPHIDIIFORMES
OPH	Ophidiidae	Cusk-eels, brotulas nei	Abadèches, brotules nca	Brótulas, congribadejos nep	Ophidiidae	OPHIDIIFORMES
OOA	Ophidion barbatum	Snake blenny			Ophidiidae	OPHIDIIFORMES
	Ophidion lozanoi				Ophidiidae	OPHIDIIFORMES
	Rouleina maderensis	Madeiran smooth-head			Alepocephalidae	Osmeriformes
	Conocara macropterus	Longfin smooth-head			Alepocephalidae	Osmeriformes
BVY	Bathylagidae	Deep-sea smelts nei			Bathylagidae	Osmeriformes
	Bathylagoides argyrogaster	Silver deepsea smelt			Bathylagidae	Osmeriformes
	Maulisia maui	Maul's searsid			Platyroctidae	Osmeriformes
	Maulisia microlepis	Smallscale searsid			Platyroctidae	Osmeriformes
BLE	Blenniidae	Combtooth blennies	Blennies(=Baveuses)	Babosas	Blenniidae	OTHER PERCIFORMES
EOC	Entomacrodus cadenati	West African rockhopper			Blenniidae	OTHER PERCIFORMES
HYQ	Hyleurochilus aequipinnis	Oyster blenny			Blenniidae	OTHER PERCIFORMES
	Hyleurochilus langi				Blenniidae	OTHER PERCIFORMES
	Lipophrys bauchotae				Blenniidae	OTHER PERCIFORMES
	Lipophrys velifer				Blenniidae	OTHER PERCIFORMES
	Parablennius incognitus				Blenniidae	OTHER PERCIFORMES
	Parablennius verruckeni				Blenniidae	OTHER PERCIFORMES
YST	Paralipophrys trigloides				Blenniidae	OTHER PERCIFORMES
LLR	Scartella cristata	Molly miller			Blenniidae	OTHER PERCIFORMES
	Draculo shango				Callionymidae	OTHER PERCIFORMES
	Synchiropus phaeton				Callionymidae	OTHER PERCIFORMES
	Labrisomus	Hairy blenny			Labrisomidae	OTHER PERCIFORMES

	nuchipinnis					
MTF	Malacoctenus africanus				Labrisomidae	OTHER PERCIFORMES
BAG	Sphyraena afra	Guinean barracuda	Bécune guinéenne	Espetón de Guinea	Sphyraenidae	OTHER PERCIFORMES
GBA	Sphyraena barracuda	Great barracuda	Barracuda	Picuda barracuda	Sphyraenidae	OTHER PERCIFORMES
YRU	Sphyraena guachancho	Guachanche barracuda			Sphyraenidae	OTHER PERCIFORMES
YRS	Sphyraena sphyraena	European barracuda	Bécune européenne	Espetón	Sphyraenidae	OTHER PERCIFORMES
BAR	Sphyraena spp	Barracudas nei	Bécunes nca	Picudas nep	Sphyraenidae	OTHER PERCIFORMES
BAZ	Sphyraenidae	Barracudas, etc. nei	Bécunes, barracudas, nca	Barracudas, picudas, nep	Sphyraenidae	OTHER PERCIFORMES
TDA	Tripterygion delaisi	Black-faced blenny			Tripterygiidae	OTHER PERCIFORMES
	Synagrops bellus	Blackmouth bass	Macondes nca	Macondas, dentiños nep	Acropomatidae	Perciformes
	Gymnammodytes cicereus	Mediterranean sand eel			Ammodytidae	Perciformes
	Parablennius dialloi				Blenniidae	Perciformes
	Parablennius goreensis				Blenniidae	Perciformes
	Parablennius parvicornis	Rock-pool blenny			Blenniidae	Perciformes
	Parablennius tentacularis	Tentacled blenny			Blenniidae	Perciformes
	Prognathodes marcellae				Chaetodontidae	Perciformes
	Ctenogobius lepturus				Gobiidae	Perciformes
	Gobius rubropunctatus		Gobies de l'Atlantique nca	Góbidos, chaparrudos nep	Gobiidae	Perciformes
	Nematogobius brachynemus				Gobiidae	Perciformes
	Polydactylus spp				Polynemidae	PERCIFORMES
	Chromis cadenati	Cadenat's chromis			Pomacentridae	Perciformes
CMK	Chromis chromis	Damselfish			Pomacentridae	Perciformes
	Chromis limbata	Azores chromis			Pomacentridae	Perciformes
	Nicholsina usta collettei				Scaridae	Perciformes

	Scarus hoefleri	Guinean parrotfish	Perroquet barbe bleue	Loro barba azul	Scaridae	Perciformes
	Pseudotolithus epipercus	Guinea croaker			Sciaenidae	PERCIFORMES
	Pseudotolithus senegallus	Law croaker			Sciaenidae	PERCIFORMES
	Diplodus sargus cadenati	Moroccan white seabream	Sar commun	Sargo	Sparidae	Perciformes
	Diplodus sargus sargus	White seabream	Sar commun	Sargo	Sparidae	Perciformes
	Trachinus armatus	Guinean weever	Vives nca	Arañas nep	Trachinidae	Perciformes
	Trachinus collignoni	Sailfin weever	Vives nca	Arañas nep	Trachinidae	Perciformes
	Trachinus lineolatus	Striped weever	Vives nca	Arañas nep	Trachinidae	Perciformes
	Trachinus pellegrini	Cape Verde weever	Vives nca	Arañas nep	Trachinidae	Perciformes
	Trachinus radiatus	Starry weever	Vives nca	Arañas nep	Trachinidae	Perciformes
	Pachycara crassiceps				Zoarcidae	Perciformes
	Pachycara crossacanthum				Zoarcidae	Perciformes
	Blennius normani				Blenniidae	Perciformes
	Spaniblennius clandestinus				Blenniidae	Perciformes
	Bathygobius burtoni				Gobiidae	Perciformes
	Bathygobius casamancus				Gobiidae	Perciformes
BJO	Bathygobius soporator	Frillfin goby			Gobiidae	Perciformes
	Lesueurigobius koumansi				Gobiidae	Perciformes
	Labrus mixtus	Cuckoo wrasse	Merle	Merlo	Labridae	Perciformes
	Branchiostegus semifasciatus	Zebra tilefish			Malacanthidae	Perciformes
	Sparisoma rubripinne	Redfin parrotfish	Perroquet vieillard	Loro viejo	Scaridae	Perciformes
ACR	Acropomatidae	Glow-bellies, splitfins nei	Macondes, etc. nca	Farolitos nep	Acropomatidae	PERCOIDEI
	Synagrops microlepis	Thinlip splitfin	Macondes nca	Macondas, dentifios nep	Acropomatidae	PERCOIDEI
SYS	Synagrops spp	Splitfins nei	Macondes nca	Macondas, dentifios nep	Acropomatidae	PERCOIDEI

	Apogon imberbis	Cardinalfish			Apogonidae	PERCOIDEI
APO	Apogonidae	Cardinalfishes, etc. nei	Apogonidés nca	Peces cardenal, etc. nep	Apogonidae	PERCOIDEI
TIS	Branchiostegidae	Tilefishes nei	Tiles nca	Blanquillos, paletas nep	Branchiostegidae	PERCOIDEI
ALA	Alectis alexandrinus	Alexandria pompano / African theadfish	Cordonnier bossu	Jurel de Alejandría	Carangidae	PERCOIDEI
LIJ	Alectis ciliaris	African pompano	Cordonnier fil	Pámpano de hebra	Carangidae	PERCOIDEI
VAD	Campogramma glaycos	Vadigo	Liche lirio	Lirio	Carangidae	PERCOIDEI
CGX	Carangidae	Carangids nei	Carangidés nca	Carángidos nep	Carangidae	PERCOIDEI
RUB	Caranx crysos	Blue runner	Carangue coubali	Cojinúa negra	Carangidae	PERCOIDEI
WFF	Caranx fischeri	Longfin crevalle jack	Carangue de Fischer	Jurel de Fischer	Carangidae	PERCOIDEI
CVJ	Caranx hippos	Crevalle jack	Carangue crevalle	Jurel común	Carangidae	PERCOIDEI
NXU	Caranx lugubris	Black jack			Carangidae	PERCOIDEI
HMY	Caranx rhonchus	False scad	Comète coussut	Macarela real	Carangidae	PERCOIDEI
NXS	Caranx senegallus	Senegal jack			Carangidae	PERCOIDEI
TRE	Caranx spp	Jacks, crevalles nei	Chinchards, carangues nca	Jureles, pámpanos nep	Carangidae	PERCOIDEI
BUA	Chloroscombrus chrysurus	Atlantic bumper	Sapater	Casabe	Carangidae	PERCOIDEI
BUZ	Chloroscombrus spp	Bumpers nei	Sapaters nca	Casabes nep	Carangidae	PERCOIDEI
WEC	Decapterus punctatus	Round scad	Comète quiaquia	Macarela chuparaco(=Surela)	Carangidae	PERCOIDEI
SDX	Decapterus spp	Scads nei	Comètes nca	Macarelas nep	Carangidae	PERCOIDEI
RRU	Elagatis bipinnulata	Rainbow runner	Comète saumon	Macarela salmón	Carangidae	PERCOIDEI
HXB	Hemicaranx bicolor	Bicolor jack	Carangue bicolore	Casabe bicolor	Carangidae	PERCOIDEI
LEE	Lichia amia	Leerfish	Liche	Palometón	Carangidae	PERCOIDEI
NAU	Naucrates ductor	Pilotfish	Poisson pilote	Pez piloto	Carangidae	PERCOIDEI
BIS	Selar crumenophthalmus	Bigeye scad	Sélar coulisou	Chicharro oión	Carangidae	PERCOIDEI
LUK	Selene dorsalis	African moonfish	Musso africain	Jorobado africano	Carangidae	PERCOIDEI
RLR	Seriola carpenteri	Guinean amberjack	Sériole guinéenne	Medregal de Guinea	Carangidae	PERCOIDEI
AMB	Seriola dumerili	Greater amberjack	Sériole couronnée	Pez de limón	Carangidae	PERCOIDEI
YTL	Seriola rivoliana	Longfin yellowtail	Sériole limon	Medregal limón	Carangidae	PERCOIDEI

AMX	Seriola spp	Amberjacks nei	Sérioles nca	Medregales nep	Carangidae	PERCOIDEI
TOG	Trachinotus goreensis	Longfin pompano	Pompaneau tacheté	Pámpano cojonovo	Carangidae	PERCOIDEI
TOO	Trachinotus maxillosus	Guinean pompano	Pompaneau chevron	Pámpano galonero	Carangidae	PERCOIDEI
POP	Trachinotus ovatus	Pompano	Palomine	Pámpano blanco	Carangidae	PERCOIDEI
POX	Trachinotus spp	Pompanos nei	Pompaneaux nca	Pámpanos(=Palome tas) nep	Carangidae	PERCOIDEI
TIE	Trachinotus teraia	Shortfin pompano	Pompaneau né-bé	Pámpano terayo	Carangidae	PERCOIDEI
HMC	Trachurus capensis	Cape horse mackerel	Chinchard du Cap	Jurel del Cabo	Carangidae	PERCOIDEI
JAX	Trachurus spp	Jack and horse mackerels nei	Chinchards noirs nca	Jureles nep	Carangidae	PERCOIDEI
HOM	Trachurus trachurus	Atlantic horse mackerel	Chinchard d'Europe	Jurel	Carangidae	PERCOIDEI
HMZ	Trachurus trecae	Cunene horse mackerel	Chinchard du Cunène	Jurel de Cunene	Carangidae	PERCOIDEI
USE	Uraspis secunda	Cottonmouth jack	Carangue coton	Jurel volantín	Carangidae	PERCOIDEI
CEZ	Centracanthidae	Picarels, etc. nei	Picarels, etc. nca	Picareles, etc. nep	Centracanthidae	PERCOIDEI
	Spicara alta	Bigeye picarel	Mendoles, picarels nca	Chuclas, carameles nep	Centracanthidae	PERCOIDEI
TAC	Spicara melanurus	Blackspot picarel	Picarel de l'Atlantique sud-es	Sucla	Centracanthidae	PERCOIDEI
PIC	Spicara spp	Picarels nei	Mendoles, picarels nca	Chuclas, carameles nep	Centracanthidae	PERCOIDEI
CBC	Cepola macrophthalma	Red bandfish	Cépole commune	Cepola	Cepolidae	PERCOIDEI
	Cepola pauciradiata		Cépole commune	Cepola	Cepolidae	PERCOIDEI
HTH	Chaetodon hoefleri	Four-banded butterflyfish			Chaetodontidae	PERCOIDEI
BUS	Chaetodontidae	Butterflyfishes	Papillons	Pescados mariposa	Chaetodontidae	PERCOIDEI
TLR	Tilapia rendalli	Redbreast tilapia			Cichlidae	PERCOIDEI
CFW	Coryphaena equiselis	Pompano dolphinfish			Coryphaenidae	PERCOIDEI
DOL	Coryphaena hippurus	Common dolphinfish	Coryphène commune	Lampuga	Coryphaenidae	PERCOIDEI
DOX	Coryphaenidae	Dolphinfishes nei	Coryphènes nca	Dorados nep	Coryphaenidae	PERCOIDEI
SIC	Drepane africana	African sicklefish	Forgeron ailé	Catemo africano	Drepanidae	PERCOIDEI
ECN	Echeneidae	Suckerfishes, remoras nei	Rémoras nca	Remoras, pegas nep	Echeneidae	PERCOIDEI

EHN	Echeneis naucrates	Live sharksucker	Rémora commun	Pegatimón	Echeneidae	PERCOIDEI
REO	Remora remora	Shark sucker			Echeneidae	PERCOIDEI
EMT	Emmelichthyidae	Bonnetmouths, rubyfishes nei	Andorrèves, poissons rubis nca	Andorreros, peces rubí nep	Emmelichthyidae	PERCOIDEI
EYO	Erythrocles monodi	Atlantic rubyfish			Emmelichthyidae	PERCOIDEI
MFF	Eucinostomus melanopterus	Flagfin mojarra	Blanche drapeau	Mojarrita de ley	Gerreidae	PERCOIDEI
GDJ	Gerreidae	Mojarras, etc. nei	Blanches, etc. nca	Mojarras, etc. nep	Gerreidae	PERCOIDEI
GEZ	Gerres nigri	Guinean striped mojarra	Friture rayée	Mojarra guineana	Gerreidae	PERCOIDEI
MOJ	Gerres spp	Mojarras(=Silver-biddies) nei	Blanches nca	Mojarras nep	Gerreidae	PERCOIDEI
GRB	Brachydeuterus auritus	Bigeye grunt	Lippu pelon	Burro ojón	Haemulidae	PERCOIDEI
GRX	Haemulidae (=Pomadasyidae)	Grunts, sweetlips nei	Grondeurs, diagrammes nca	Burros, roncós nep	Haemulidae	PERCOIDEI
PKC	Parakuhlia macrophthalmus	Dara			Haemulidae	PERCOIDEI
GBL	Plectorhinchus macrolepis	Biglip grunt	Diagramme à grosses lèvres	Burro labiogrueso	Haemulidae	PERCOIDEI
GBR	Plectorhinchus mediterraneus	Rubberlip grunt	Diagramme gris	Burro chiclero	Haemulidae	PERCOIDEI
PBX	Plectorhinchus spp	Sweetlips, rubberlips nei			Haemulidae	PERCOIDEI
BGR	Pomadasy incisus	Bastard grunt	Grondeur métis	Ronco mestizo	Haemulidae	PERCOIDEI
BUR	Pomadasy jubelini	Sompat grunt	Grondeur sompat	Ronco sompat	Haemulidae	PERCOIDEI
PKE	Pomadasy perotaei	Parrot grunt			Haemulidae	PERCOIDEI
	Pomadasy rogerii	Pignout grunt			Haemulidae	PERCOIDEI
BGX	Pomadasy spp				Haemulidae	PERCOIDEI
PKK	Pomadasy suillus				Haemulidae	PERCOIDEI
KYX	Kyphosidae	Sea chubs nei	Calicagères nca	Chopas nep	Kyphosidae	PERCOIDEI
KYP	Kyphosus spp	Kyphosus sea chubs nei	Kyphosus calicagères nca	Kyphosus chopas nep	Kyphosidae	PERCOIDEI
	Bodianus speciosus	Blackbar hogfish			Labridae	PERCOIDEI
WRA	Labridae	Wrasses, hogfishes, etc. nei	Pourceaux, donzelles, etc. nca	Lábridos(=Tordos,m aragotas)nep	Labridae	PERCOIDEI

XYN	Xyrichtys novacula	Pearly razorfish	Donzelle lame	Rao	Labridae	PERCOIDEI
EMP	Lethrinidae	Emperors(=Scavengers) nei	Empereurs nca	Emperadores nep	Lethrinidae	PERCOIDEI
LTN	Lethrinus atlanticus	Atlantic emperor	Empereur atlantique	Emperador atlántico	Lethrinidae	PERCOIDEI
LOB	Lobotes surinamensis	Tripletail	Croupia roche	Dormilona	Lobotidae	PERCOIDEI
AFK	Apsilus fuscus	African forktail snapper	Vivaneau fourche d'Afrique	Pargo tijera	Lutjanidae	PERCOIDEI
SNX	Lutjanidae	Snappers, jobfishes nei	Lutianidés nca	Lutjánidos nep	Lutjanidae	PERCOIDEI
LJA	Lutjanus agennes	African red snapper	Vivaneau africain rouge	Pargo colorado africano	Lutjanidae	PERCOIDEI
LJE	Lutjanus dentatus	African brown snapper	Vivaneau brun d'Afrique	Pargo marrón africano	Lutjanidae	PERCOIDEI
	Lutjanus endecacanthus	Guinea snapper	Vivaneaux nca	Pargos tropicales nep	Lutjanidae	PERCOIDEI
LVN	Lutjanus fulgens	Golden African snapper	Vivaneau doré	Pargo dorado africano	Lutjanidae	PERCOIDEI
LJO	Lutjanus goreensis	Gorean snapper	Vivaneau de Gorée	Pargo de Gorea	Lutjanidae	PERCOIDEI
SNA	Lutjanus spp	Snappers nei	Vivaneaux nca	Pargos tropicales nep	Lutjanidae	PERCOIDEI
	Monodactylus sebae	African moony			Monodactylidae	PERCOIDEI
BSS	Dicentrarchus labrax	European seabass	Bar européen	Lubina	Moronidae	PERCOIDEI
MUM	Mullidae	Goatfishes, red mullets nei	Rougets, etc. nca	Salmonetes, etc. nep	Mullidae	PERCOIDEI
MUT	Mullus barbatus	Red mullet	Rouget de vase	Salmonete de fango	Mullidae	PERCOIDEI
MUX	Mullus spp	Surmullet(=Red mullets) nei	Rougets nca	Salmonetes nep	Mullidae	PERCOIDEI
MUR	Mullus surmuletus	Surmullet	Rouget de roche	Salmonete de roca	Mullidae	PERCOIDEI
GOA	Pseudupeneus prayensis	West African goatfish	Rouget du Sénégal	Salmonete barbudo	Mullidae	PERCOIDEI
GAL	Galeoides decadactylus	Lesser African threadfin	Petit capitaine	Barbudo enano africano	Polynemidae	PERCOIDEI
PET	Pentanemus quinquarius	Royal threadfin	Capitaine royal	Barbudo real	Polynemidae	PERCOIDEI
TGA	Polydactylus quadrifilis	Giant African threadfin	Gros capitaine	Barbudo gigante africano	Polynemidae	PERCOIDEI
THF	Polynemidae	Threadfins,	Barbures, capitaines	Barbudos nep	Polynemidae	PERCOIDEI

		tasselfishes nei	nca			
WRF	Polypriion americanus	Wreckfish	Cernier commun	Cherna	Polyprionidae	PERCOIDEI
	Holacanthus africanus	Guinean angelfish			Pomacanthidae	PERCOIDEI
ANW	Pomacanthidae	Angelfishes nei	Demoiselles nca	Angeles nep	Pomacanthidae	PERCOIDEI
AUU	Abudefduf luridus	Canary damsel			Pomacentridae	PERCOIDEI
ABU	Abudefduf saxatilis	Sergeant-major			Pomacentridae	PERCOIDEI
	Abudefduf taurus	Night sergeant			Pomacentridae	PERCOIDEI
	Microspathodon frontatus	Guinean damselfish			Pomacentridae	PERCOIDEI
	Stegastes imbricatus	Cape Verde gregory			Pomacentridae	PERCOIDEI
TGE	Stegastes leucostictus	Beaugregory			Pomacentridae	PERCOIDEI
POT	Pomatomidae	Bluefishes nei	Tassergals nca	Anchovas nep	Pomatomidae	PERCOIDEI
BLU	Pomatomus saltatrix	Bluefish	Tassergal	Anjova	Pomatomidae	PERCOIDEI
PRI	Priacanthidae	Bigeyes, glasseyes, bulleyes nei	Beauclaires, etc. nca	Catalufas, etc. nep	Priacanthidae	PERCOIDEI
PQR	Priacanthus arenatus	Atlantic bigeye			Priacanthidae	PERCOIDEI
CBA	Rachycentron canadum	Cobia	Mafou	Cobia	Rachycentridae	PERCOIDEI
PWT	Scaridae	Parrotfishes nei	Perroquets nca	Loros nep	Scaridae	PERCOIDEI
PRR	Sparisoma cretense	Parrotfish	Perroquet vieillard	Loro viejo	Scaridae	PERCOIDEI
MGR	Argyrosomus regius	Meagre	Maigre commun	Corvina	Sciaenidae	PERCOIDEI
MIV	Miracorvina angolensis	Angola croaker			Sciaenidae	PERCOIDEI
THZ	Pentheroscion mbizi	Blackmouth croaker			Sciaenidae	PERCOIDEI
CKL	Pseudotolithus brachygnathus	Law croaker	Otolithe gabo	Corvina reina	Sciaenidae	PERCOIDEI
PSE	Pseudotolithus elongatus	Bobo croaker	Otolithe bobo	Corvina bobo	Sciaenidae	PERCOIDEI
UDM	Pseudotolithus moorii	Cameroon croaker			Sciaenidae	PERCOIDEI
PSS	Pseudotolithus senegalensis	Cassava croaker	Otolithe sénégalais	Corvina casava	Sciaenidae	PERCOIDEI
CKW	Pseudotolithus spp	West African croakers nei	Otolithes nca	Corvinas africanas nep	Sciaenidae	PERCOIDEI
PTY	Pseudotolithus typus	Longneck croaker	Otolithe nanka	Corvina bosoro	Sciaenidae	PERCOIDEI
DRS	Pteroscion peli	Boe drum	Courbine pélin	Bombache boe	Sciaenidae	PERCOIDEI

CBM	Sciaena umbra	Brown meagre	Corb commun	Corvallo	Sciaenidae	PERCOIDEI
CDX	Sciaenidae	Croakers, drums nei	Sciaenidés nca	Esciéndidos nep	Sciaenidae	PERCOIDEI
UCA	Umbrina canariensis	Canary drum (=Baardman)	Ombrine bronze	Verrugato de Canarias	Sciaenidae	PERCOIDEI
UMO	Umbrina ronchus	Fusca drum			Sciaenidae	PERCOIDEI
UBS	Umbrina spp	Drums nei	Ombrines nca	Verrugatos nep	Sciaenidae	PERCOIDEI
AHN	Anthias anthias	Swallowtail seaperch			Serranidae	PERCOIDEI
CFQ	Cephalopholis nigri	Niger hind	Mérou du Niger	Cherna del Niger	Serranidae	PERCOIDEI
EFA	Cephalopholis taeniops	Bluespotted seabass; African hind	Mérou à points bleus	Cherna colorada	Serranidae	PERCOIDEI
GPW	Epinephelus aeneus	White grouper	Mérou blanc	Cherna de ley	Serranidae	PERCOIDEI
EFJ	Epinephelus caninus	Dogtooth grouper	Mérou gris	Mero dentón	Serranidae	PERCOIDEI
EPK	Epinephelus costae	Goldblotch grouper	Mérou badèche	Falso abadejo	Serranidae	PERCOIDEI
EEG	Epinephelus goreensis	Dungat grouper	Mérou de Gorée	Mero de Gorea	Serranidae	PERCOIDEI
EEL	Epinephelus haifensis	Haifa grouper	Mérou d'Haifa	Mero de Haifa	Serranidae	PERCOIDEI
EET	Epinephelus itajara	Jewfish	Mérou géant	Mero guasa	Serranidae	PERCOIDEI
GPD	Epinephelus marginatus	Dusky grouper	Mérou noir	Mero moreno	Serranidae	PERCOIDEI
GPX	Epinephelus spp	Groupers nei	Mérous nca	Meros nep	Serranidae	PERCOIDEI
MKU	Mycteroperca rubra	Mottled grouper	Badèche rouge	Gitano	Serranidae	PERCOIDEI
RYC	Rypticus saponaceus	Greater soapfish			Serranidae	PERCOIDEI
	Rypticus subbifrenatus	Spotted soapfish			Serranidae	PERCOIDEI
BSX	Serranidae	Groupers, seabasses nei	Serranidés nca	Meros, chernas, nep	Serranidae	PERCOIDEI
	Serranus accraensis	Ghanean comber	Serran-chèvre	Cabrilla	Serranidae	PERCOIDEI
	Serranus africanus		Serran-chèvre	Cabrilla	Serranidae	PERCOIDEI
CBR	Serranus cabrilla	Comber	Serran-chèvre	Cabrilla	Serranidae	PERCOIDEI
BAS	Serranus spp	Combers nei	Serrans nca	Serranos nep	Serranidae	PERCOIDEI
BOG	Boops boops	Bogue	Bogue	Boga	Sparidae	PERCOIDEI
DEA	Dentex angolensis	Angolan dentex	Denté angolais	Dentón angoleño	Sparidae	PERCOIDEI
	Dentex barnardi	Barnard's dentex	Denté à tache rouge	Chacarona de Canarias	Sparidae	PERCOIDEI
DEN	Dentex canariensis	Canary dentex	Denté à tache rouge	Chacarona de Canarias	Sparidae	PERCOIDEI
DNC	Dentex congoensis	Congo dentex	Denté congolais	Dentón congolés	Sparidae	PERCOIDEI

DEC	Dentex dentex	Common dentex	Denté commun	Dentón	Sparidae	PERCOIDEI
DEP	Dentex gibbosus	Pink dentex	Gros denté rose	Sama de pluma	Sparidae	PERCOIDEI
DEL	Dentex macrophthalmus	Large-eye dentex	Denté à gros yeux	Cachucho	Sparidae	PERCOIDEI
DEM	Dentex maroccanus	Morocco dentex	Denté du Maroc	Sama marroquí	Sparidae	PERCOIDEI
DEX	Dentex spp	Dentex nei	Dentés nca	Dentones, samas, etc. nep	Sparidae	PERCOIDEI
SBZ	Diplodus cervinus	Zebra seabream	Sar à grosses lèvres	Sargo breado	Sparidae	PERCOIDEI
SHR	Diplodus puntazzo	Sharpsnout seabream	Sar à museau pointu	Sargo picudo	Sparidae	PERCOIDEI
SRG	Diplodus spp	Sargo breams nei	Sars, sparillons nca	Sargos, raspallones nep	Sparidae	PERCOIDEI
CTB	Diplodus vulgaris	Common two-banded seabream	Sar à tête noire	Sargo mojarra	Sparidae	PERCOIDEI
SSB	Lithognathus mormyrus	Sand steenbras	Marbré	Herrera	Sparidae	PERCOIDEI
SBS	Oblada melanura	Saddled seabream	Oblade	Oblada	Sparidae	PERCOIDEI
SBA	Pagellus acarne	Axillary seabream	Pageot acarne	Aligote	Sparidae	PERCOIDEI
PAR	Pagellus bellottii	Red pandora	Pageot à tache rouge	Breca chata	Sparidae	PERCOIDEI
PAC	Pagellus erythrinus	Common pandora	Pageot commun	Breca	Sparidae	PERCOIDEI
PAX	Pagellus spp	Pandoras nei	Pageots nca	Brecas nep	Sparidae	PERCOIDEI
	Pagrus africanus	Southern common seabream	Pagre rayé	Pargo sémola	Sparidae	PERCOIDEI
REA	Pagrus auriga	Redbanded seabream	Pagre rayé	Pargo sémola	Sparidae	PERCOIDEI
BSC	Pagrus caeruleostictus	Bluespotted seabream	Pagre à points bleus	Hurta(=Zapata)	Sparidae	PERCOIDEI
RPG	Pagrus pagrus	Red porgy	Pagre rouge	Pargo	Sparidae	PERCOIDEI
SBP	Pagrus spp	Pargo breams nei	Dorades nca	Pargos nep	Sparidae	PERCOIDEI
SLM	Sarpa salpa	Salema	Saupe	Salema	Sparidae	PERCOIDEI
SBX	Sparidae	Porgies, seabreams nei	Dentés, spares nca	Dentones, sargos nep	Sparidae	PERCOIDEI
SBG	Sparus aurata	Gilthead seabream	Dorade royale	Dorada	Sparidae	PERCOIDEI
BRB	Spondyliosoma cantharus	Black seabream	Dorade grise	Chopa	Sparidae	PERCOIDEI
PRC	Percoidei	Percoids nei	Percoides nca	Percoideos nep		PERCOIDEI

FIN	Osteichthyes	Finfishes nei	Poissons téléostéens nca	Peces de escama nep		PISCES MISCELLANEA
MZZ	Osteichthyes	Marine fishes nei	Poissons marins nca	Peces marinos nep		PISCES MISCELLANEA
RGK	Arnoglossus capensis	Cape scaldfish			Bothidae	PLEURONECTIFORMES
RLI	Arnoglossus imperialis	Imperial scaldfish			Bothidae	PLEURONECTIFORMES
MSF	Arnoglossus laterna	Mediterranean scaldfish	Arnoglosse de Méditerranée	Serrandell	Bothidae	PLEURONECTIFORMES
RNH	Arnoglossus thori	Thor's scaldfish			Bothidae	PLEURONECTIFORMES
LEF	Bothidae	Lefteye flounders nei	Arnoglosses, rombous nca	Rodaballos, rombos, etc. nep	Bothidae	PLEURONECTIFORMES
OUB	Bothus podas	Wide-eyed flounder			Bothidae	PLEURONECTIFORMES
	Monolene mertensi	Merten's moonflounder			Bothidae	PLEURONECTIFORMES
CIT	Citharidae	Citharids nei	Feuilles nca	Solletas nep	Citharidae	PLEURONECTIFORMES
CIL	Citharus linguatula	Spotted flounder	Feuille	Solleta	Citharidae	PLEURONECTIFORMES
TOX	Cynoglossidae	Tonguefishes	Cynoglossidés	Cinoglósidos	Cynoglossidae	PLEURONECTIFORMES
	Cynoglossus browni	Nigerian tonguesole			Cynoglossidae	PLEURONECTIFORMES
	Cynoglossus cadenati	Ghanian tonguesole			Cynoglossidae	PLEURONECTIFORMES
YOI	Cynoglossus canariensis	Canary tonguesole	Sole-langue canarienne	Lengua de Canarias	Cynoglossidae	PLEURONECTIFORMES
	Cynoglossus monodi	Guinean tonguesole			Cynoglossidae	PLEURONECTIFORMES
YOE	Cynoglossus senegalensis	Senegalese tonguesole	Sole-langue sénégalaise	Lengua del Senegal	Cynoglossidae	PLEURONECTIFORMES
YOX	Cynoglossus spp	Tonguesole nei	Sole-langues nca	Lenguas nep	Cynoglossidae	PLEURONECTIFORMES
YFU	Symphurus ligulatus	Elongate tonguesole			Cynoglossidae	PLEURONECTIFORMES
	Symphurus vanmelleae				Cynoglossidae	PLEURONECTIFORMES
IYT	Citharichthys stampflii	Smooth flounder			Paralichthyidae	PLEURONECTIFORMES
	Syacium guineensis				Paralichthyidae	PLEURONECTIFORMES
SOT	Psettodes belcheri	Spottail spiny turbot	Turbot épineux tacheté	Perro	Psettodidae	PLEURONECTIFORMES
PSB	Psettodes bennettii	Spiny turbot	Turbot épineux	Lenguado espinudo	Psettodidae	PLEURONECTIFORMES
	Bathysolea polli				Soleidae	PLEURONECTIFORMES
	Bathysolea profundicola	Deepwater sole			Soleidae	PLEURONECTIFORMES
GSM	Buglossidium luteum	Solenette			Soleidae	PLEURONECTIFORMES

DHZ	Dicologlossa hexophthalma	Ocellated wedge sole	Céteau ocellé	Acedía ocelada	Soleidae	PLEURONECTIFORMES
	Heteromycteris proboscideus	True sole			Soleidae	PLEURONECTIFORMES
	Microchirus boscanion	Lusitanian sole			Soleidae	PLEURONECTIFORMES
	Microchirus frechkopi	Frechkop's sole			Soleidae	PLEURONECTIFORMES
MRK	Microchirus ocellatus	Foureyed sole			Soleidae	PLEURONECTIFORMES
THS	Microchirus spp	Thickback soles	Soles-perdix	Golletas	Soleidae	PLEURONECTIFORMES
	Microchirus theophila	Bastard sole			Soleidae	PLEURONECTIFORMES
MKG	Microchirus variegatus	Thickback sole			Soleidae	PLEURONECTIFORMES
	Microchirus wittei	Banded sole			Soleidae	PLEURONECTIFORMES
MHH	Monochirus hispidus	Whiskered sole			Soleidae	PLEURONECTIFORMES
SOS	Pegusa lascaris	Sand sole	Sole-pole	Lenguado de arena	Soleidae	PLEURONECTIFORMES
OAL	Solea senegalensis	Senegalese sole	Sole du Sénégal	Lenguado senegalés	Soleidae	PLEURONECTIFORMES
SOL	Solea solea	Common sole	Sole commune	Lenguado común	Soleidae	PLEURONECTIFORMES
SOO	Solea spp				Soleidae	PLEURONECTIFORMES
SOX	Soleidae	Soles nei	Soles nca	Lenguados nep	Soleidae	PLEURONECTIFORMES
YNY	Synaptura cadenati	Guinean sole	Sole-ruardon du Golfe	Lenguado de Guinea	Soleidae	PLEURONECTIFORMES
YNU	Synaptura lusitanica	Portuguese sole			Soleidae	PLEURONECTIFORMES
VNC	Vanstraelenia chirophthalmus	African solenette			Soleidae	PLEURONECTIFORMES
	Pegusa triophthalma	Cyclope sole			Soleidae	PLEURONECTIFORMES
FLX	Pleuronectiformes	Flatfishes nei	Poissons plats nca	Peces planos nep		PLEURONECTIFORMES
PZC	Alepocephalidae				Alepocephalidae	SALMONIFORMES
	Alepocephalus australis	small scaled borwn slickhead			Alepocephalidae	SALMONIFORMES
PHO	Alepocephalus rostratus	Risso's smooth-head		Talisman	Alepocephalidae	SALMONIFORMES
ALH	Alepocephalus spp	Slickheads nei		Talismans	Alepocephalidae	SALMONIFORMES
AQC	Asquamiceps caeruleus				Alepocephalidae	SALMONIFORMES
	Bathytroctes michaelisarsari	Michael Sars smooth-head			Alepocephalidae	SALMONIFORMES
AYM	Bathytroctes	Smallscale smooth-			Alepocephalidae	SALMONIFORMES

	microlepis	head				
	Einara macrolepis	Loosescale smooth-head			Alepocephalidae	SALMONIFORMES
AEK	Herwigia krefftii	Krefft's smooth-head			Alepocephalidae	SALMONIFORMES
	Leptoderma macrops	Grenadier smooth-head			Alepocephalidae	SALMONIFORMES
PHP	Photostylus pycnopterus	Starry smooth-head			Alepocephalidae	SALMONIFORMES
	Talismania antillarum	Antillean smooth-head			Alepocephalidae	SALMONIFORMES
	Talismania homoptera	Hairfin smooth-head			Alepocephalidae	SALMONIFORMES
	Talismania longifilis	Longtail slickhead			Alepocephalidae	SALMONIFORMES
	Talismania mekistonema	Threadfin smooth-head			Alepocephalidae	SALMONIFORMES
AXC	Xenodermichthys copei	Bluntnout smooth-head			Alepocephalidae	SALMONIFORMES
	Glossanodon polli		Argentina du Pacifique	Argentina del Pacifico	Argentinidae	SALMONIFORMES
LLG	Leptoichthys agassizii	Agassiz' smooth-head			Leptoichthyidae	SALMONIFORMES
ODB	Dolichopteryx binocularis				Opisthoproctidae	SALMONIFORMES
OOL	Opisthoproctus soleatus	Barrel-eye			Opisthoproctidae	SALMONIFORMES
OWT	Winteria telescopa	Binocular fish			Opisthoproctidae	SALMONIFORMES
PBC	Barbantus curvifrons	Palebelly searsid			Platyroctidae	SALMONIFORMES
PHN	Holtbyrnia anomala	Bighead searsid			Platyroctidae	SALMONIFORMES
	Holtbyrnia innesi	Teardrop tubeshoulder			Platyroctidae	SALMONIFORMES
	Holtbyrnia macrops	Bigeye searsid			Platyroctidae	SALMONIFORMES
PMO	Normichthys operosus	Multipore searsid			Platyroctidae	SALMONIFORMES
PYA	Platyroctes apus	Legless searsid			Platyroctidae	SALMONIFORMES
	Sagamichthys schnakenbecki	Schnakenbeck's searsid			Platyroctidae	SALMONIFORMES
PSO	Searsia koefoedi	Koefoed's searsid			Platyroctidae	SALMONIFORMES
SLX	Salmonoidei	Salmonoids nei	Salmonoidés nca	Salmonoideos nep		SALMONIFORMES

DLT	Diplospinus multistriatus	Striped escolar	Escolier rayé	Escolar rayado	Gempylidae	SCOMBROIDEI
GEP	Gempylidae	Snake mackerels, escolars nei	Escoliers, rouvets nca	Escolares, sierras nep	Gempylidae	SCOMBROIDEI
GES	Gempylus serpens	Snake mackerel	Escolier serpent	Escolar de canal	Gempylidae	SCOMBROIDEI
LEC	Lepidocybium flavobrunneum	Escolar	Escolier noir	Escolar negro	Gempylidae	SCOMBROIDEI
NLT	Nealotus tripes	Black snake mackerel	Escolier reptile	Escolar oscuro	Gempylidae	SCOMBROIDEI
NEN	Nesiarchus nasutus	Black gemfish	Escolier long nez	Escolar narigudo	Gempylidae	SCOMBROIDEI
PRP	Promethichthys prometheus	Roudi escolar	Escolier clair	Escolar prometeo	Gempylidae	SCOMBROIDEI
OIL	Ruvettus pretiosus	Oilfish	Rouvet	Escolar clavo	Gempylidae	SCOMBROIDEI
BIL	Istiophoridae	Marlins, sailfishes, etc. nei	Makaires, marlins, voilier s nca	Agujas, marlines, peces vela nep	Istiophoridae	SCOMBROIDEI
SAI	Istiophorus albicans	Atlantic sailfish	Voilier de l'Atlantique	Pez vela del Atlántico	Istiophoridae	SCOMBROIDEI
BLM	Makaira indica	Black marlin	Makaire noir	Aguja negra	Istiophoridae	SCOMBROIDEI
BUM	Makaira nigricans	Blue marlin	Makaire bleu	Aguja azul	Istiophoridae	SCOMBROIDEI
WHM	Tetrapturus albidus	Atlantic white marlin	Makaire blanc de l'Atlantique	Aguja blanca del Atlántico	Istiophoridae	SCOMBROIDEI
SSP	Tetrapturus angustirostris	Shortbill spearfish	Makaire à rostre court	Marlín trompa corta	Istiophoridae	SCOMBROIDEI
SPF	Tetrapturus pfluegeri	Longbill spearfish	Makaire bécune	Aguja picuda	Istiophoridae	SCOMBROIDEI
WAH	Acanthocybium solandri	Wahoo	Thazard-bâtard	Peto	Scombridae	SCOMBROIDEI
BLT	Auxis rochei	Bullet tuna	Bonitou	Melva(=Melvera)	Scombridae	SCOMBROIDEI
FRI	Auxis thazard	Frigate tuna	Auxide	Melva	Scombridae	SCOMBROIDEI
FRZ	Auxis thazard, A. rochei	Frigate and bullet tunas	Auxide et bonitou	Melva y melvera	Scombridae	SCOMBROIDEI
LTA	Euthynnus alletteratus	Little tunny(=Atl.black skipj)	Thonine commune	Bacoreta	Scombridae	SCOMBROIDEI
SKJ	Katsuwonus pelamis	Skipjack tuna	Listao	Listado	Scombridae	SCOMBROIDEI
BOP	Orcynopsis unicolor	Plain bonito	Palomette	Tasarte	Scombridae	SCOMBROIDEI
BON	Sarda sarda	Atlantic bonito	Bonite à dos rayé	Bonito del Atlántico	Scombridae	SCOMBROIDEI
BZX	Sarda spp	Bonitos nei	Bonites nca	Bonitos nep	Scombridae	SCOMBROIDEI

MAS	Scomber japonicus	Chub mackerel	Maquereau espagnol	Estornino	Scombridae	SCOMBROIDEI
MAZ	Scomber spp	Scomber mackerels nei	Maquereaux scomber nca	Caballas scomber nep	Scombridae	SCOMBROIDEI
KGX	Scomberomorus spp	Seerfishes nei	Thazards nca	Carites nep	Scombridae	SCOMBROIDEI
MAW	Scomberomorus tritor	West African Spanish mackerel	Thazard blanc	Carite lusitánico	Scombridae	SCOMBROIDEI
MAX	Scombridae	Mackerels nei	Maquereaux nca	Caballas nep	Scombridae	SCOMBROIDEI
ALB	Thunnus alalunga	Albacore	Germon	Atún blanco	Scombridae	SCOMBROIDEI
YFT	Thunnus albacares	Yellowfin tuna	Albacore	Rabil	Scombridae	SCOMBROIDEI
BET	Thunnus obesus	Bigeye tuna	Thon obèse(=Patudo)	Patudo	Scombridae	SCOMBROIDEI
TUS	Thunnus spp	True tunas nei	Thons Thunnus nca	Atunes verdaderos nep	Scombridae	SCOMBROIDEI
BFT	Thunnus thynnus	Atlantic bluefin tuna	Thon rouge de l'Atlantique	Atún rojo del Atlántico	Scombridae	SCOMBROIDEI
BEH	Benthodesmus spp	Frostfishes			Trichiuridae	SCOMBROIDEI
	Benthodesmus tenuis	Slender frostfish			Trichiuridae	SCOMBROIDEI
SFS	Lepidopus caudatus	Silver scabbardfish	Sabre argenté	Pez cinto	Trichiuridae	SCOMBROIDEI
	Lepidopus dubius	Doubtful scabbardfish	Sabre argenté	Pez cinto	Trichiuridae	SCOMBROIDEI
CUT	Trichiuridae	Hairtails, scabbardfishes nei	Poissons-sabres, sabres nca	Peces sable, cintos nep	Trichiuridae	SCOMBROIDEI
LHT	Trichiurus lepturus	Largehead hairtail	Poisson-sabre commun	Pez sable	Trichiuridae	SCOMBROIDEI
SWO	Xiphias gladius	Swordfish	Espadon	Pez espada	Xiphiidae	SCOMBROIDEI
TUX	Scombroidei	Tuna-like fishes nei	Poissons type thon nca	Peces parec. a los atunes nep		SCOMBROIDEI
DYX	Dactylopteridae	Flying gurnards nei	Grondins volants nca	Dactilópteros nep	Dactylopteridae	SCORPAENIFORMES
DYL	Dactylopterus volitans	Flying gurnard	Grondin volant	Alón volador	Dactylopteridae	SCORPAENIFORMES
LPX	Liparidae	Snailfishes nei	Limaces de mer nca	Babosos nep	Liparidae	SCORPAENIFORMES
PCJ	Paraliparis copei				Liparidae	SCORPAENIFORMES
PJC	Peristedion cataphractum	African armoured searobin			Peristediidae	SCORPAENIFORMES
FLH	Platycephalidae	Flatheads nei	Platycéphalidés nca	Platicefálidos nep	Platycephalidae	SCORPAENIFORMES
	Solitas gruveli	Guinea flathead			Platycephalidae	SCORPAENIFORMES
PIS	Pontinus accraensis	Ghanean rockfish			Scorpaenidae	SCORPAENIFORMES
	Pontinus leda	Speckled deepwater scorpionfish			Scorpaenidae	SCORPAENIFORMES

SSW	Scorpaena angolensis	Angola rockfish			Scorpaenidae	SCORPAENIFORMES
	Scorpaena elongata	Slender rockfish			Scorpaenidae	SCORPAENIFORMES
SLQ	Scorpaena laevis	Senegalese rockfish			Scorpaenidae	SCORPAENIFORMES
	Scorpaena maderensis	Madeira rockfish			Scorpaenidae	SCORPAENIFORMES
SCS	Scorpaena normani	Norman's rockfish	Rascasses nca	Rascacios, cabrachos nep	Scorpaenidae	SCORPAENIFORMES
SNQ	Scorpaena notata	Small red scorpionfish			Scorpaenidae	SCORPAENIFORMES
RSE	Scorpaena scrofa	Red scorpionfish	Rascasse rouge	Cabracho	Scorpaenidae	SCORPAENIFORMES
SCS	Scorpaena spp	Scorpionfishes, rockfishes nei	Rascasses nca	Rascacios, cabrachos nep	Scorpaenidae	SCORPAENIFORMES
SCS	Scorpaena stephanica	Spotted-fin rockfish	Rascasses nca	Rascacios, cabrachos nep	Scorpaenidae	SCORPAENIFORMES
SCO	Scorpaenidae	Scorpionfishes nei	Rascasses, etc. nca	Rascacios, gallinetas nep	Scorpaenidae	SCORPAENIFORMES
SOF	Scorpaenodes africanus				Scorpaenidae	SCORPAENIFORMES
	Scorpaenodes elongatus				Scorpaenidae	SCORPAENIFORMES
TZY	Trachyscorpia cristulata echinata	Spiny scorpionfish	Rascasse épineuse	Rascacio espinoso	Scorpaenidae	SCORPAENIFORMES
BRF	Helicolenus dactylopterus	Blackbelly rosefish	Sébaste chèvre	Gallineta	Sebastidae	SCORPAENIFORMES
SVG	Setarches guentheri	Channeled rockfish; deepwater scorpionfish			Setarchidae	SCORPAENIFORMES
CGY	Chelidonichthys gabonensis	Gabon gurnard			Triglidae	SCORPAENIFORMES
	Lepidotrigla cadmani	Scalebreast gurnard			Triglidae	SCORPAENIFORMES
LDR	Lepidotrigla carolae	Carol's gurnard			Triglidae	SCORPAENIFORMES
GUX	Triglidae	Gurnards, searobins nei	Grondins, cavillones nca	Cabetes, rubios nep	Triglidae	SCORPAENIFORMES
CTZ	Trigloporus lastoviza	Streaked gurnard			Triglidae	SCORPAENIFORMES
	Phractura fasciata				Amphiliidae	SILURIFORMES
CAX	Ariidae	Sea catfishes nei	Mâchoirons nca	Bagres marinos nep	Ariidae	SILURIFORMES
AUG	Arius gigas	Giant sea catfish	Mâchoiron géant	Bagre gigante	Ariidae	SILURIFORMES

SMC	<i>Arius heudelotii</i>	Smoothmouth sea catfish	Mâchoiron banderille	Bagre bocalisa	Ariidae	SILURIFORMES
AUR	<i>Arius latiscutatus</i>	Rough-head sea catfish			Ariidae	SILURIFORMES
	<i>Arius parkii</i>	Guinean sea catfish			Ariidae	SILURIFORMES
AWX	<i>Arius</i> spp				Ariidae	SILURIFORMES
BPO	<i>Bonapartia pedaliota</i>	Longray fangjaw			Gonostomatidae	STOMIIFORMES
YTB	<i>Cyclothone alba</i>	Bristlemouth			Gonostomatidae	STOMIIFORMES
YTU	<i>Cyclothone braueri</i>	Garrick			Gonostomatidae	STOMIIFORMES
YTV	<i>Cyclothone livida</i>				Gonostomatidae	STOMIIFORMES
YTM	<i>Cyclothone microdon</i>	Veiled anglemouth			Gonostomatidae	STOMIIFORMES
	<i>Cyclothone obscura</i>	Hidden bristlemouth			Gonostomatidae	STOMIIFORMES
YTP	<i>Cyclothone pallida</i>	Tan bristlemouth			Gonostomatidae	STOMIIFORMES
YTX	<i>Cyclothone</i> spp				Gonostomatidae	STOMIIFORMES
DPT	<i>Diplophos taenia</i>	Pacific portholefish			Gonostomatidae	STOMIIFORMES
	<i>Gonostoma atlanticum</i>	Atlantic fangjaw			Gonostomatidae	STOMIIFORMES
GSD	<i>Gonostoma denudatum</i>				Gonostomatidae	STOMIIFORMES
GSL	<i>Gonostoma elongatum</i>	Elongated bristlemouth fish			Gonostomatidae	STOMIIFORMES
BRI	Gonostomatidae	Bristlemouths	Brossés	Moritos	Gonostomatidae	STOMIIFORMES
GSY	<i>Sigmops bathyphilus</i>	Spark anglemouth			Gonostomatidae	STOMIIFORMES
	<i>Manducus maderensis</i>				Gonostomatidae	STOMIIFORMES
OLM	<i>Pollichthys maui</i>	Stareye lightfish			Phosichthyidae	STOMIIFORMES
OLC	<i>Polymetme corythaeola</i>	Rendezvous fish			Phosichthyidae	STOMIIFORMES
VIA	<i>Vinciguerria attenuata</i>	Slender lightfish			Phosichthyidae	STOMIIFORMES
VII	<i>Vinciguerria nimbaria</i>	Oceanic lightfish			Phosichthyidae	STOMIIFORMES
VIP	<i>Vinciguerria poweriae</i>	Power's deep-water bristle-mou			Phosichthyidae	STOMIIFORMES
YAB	<i>Yarella blackfordi</i>				Phosichthyidae	STOMIIFORMES
	<i>Argyropelecus affinus</i>	Pacific hatchet fish			Sternoptychidae	STOMIIFORMES
	<i>Argyropelecus gigus</i>	hatchetfish			Sternoptychidae	STOMIIFORMES
	<i>Argyropelecus hemigymnus</i>	Half-naked hatchetfish			Sternoptychidae	STOMIIFORMES

	<i>Argyropelecus sladeni</i>	Sladen's hatchetfish			Sternoptychidae	STOMIIFORMES
MAV	<i>Maurolicus muelleri</i>	Silvery lightfish			Sternoptychidae	STOMIIFORMES
	<i>Maurolicus weitzmani</i>	Atlantic pearlside			Sternoptychidae	STOMIIFORMES
	<i>Polyipnus polli</i>				Sternoptychidae	STOMIIFORMES
HAF	Sternoptychidae	Hatchetfishes nei	Haches d'argent nca	Hachas de plata nep	Sternoptychidae	STOMIIFORMES
SXD	<i>Sternoptyx diaphana</i>	Diaphanous hatchet fish			Sternoptychidae	STOMIIFORMES
SXP	<i>Sternoptyx pseudobscura</i>	Highlight hatchetfish			Sternoptychidae	STOMIIFORMES
VAT	<i>Valenciennellus tripunctulatus</i>	Constellationfish			Sternoptychidae	STOMIIFORMES
	<i>Aristostomias polydactylus</i>				Stomiidae	STOMIIFORMES
	<i>Aristostomias xenostoma</i>				Stomiidae	STOMIIFORMES
	<i>Astronesthes caulophorus</i>				Stomiidae	STOMIIFORMES
AEG	<i>Astronesthes gemmifer</i>	Snaggletooth			Stomiidae	STOMIIFORMES
AEO	<i>Astronesthes leucopogon</i>				Stomiidae	STOMIIFORMES
	<i>Astronesthes macropogon</i>				Stomiidae	STOMIIFORMES
	<i>Astronesthes micropogon</i>				Stomiidae	STOMIIFORMES
AHR	<i>Astronesthes niger</i>				Stomiidae	STOMIIFORMES
	<i>Astronesthes richardsoni</i>	Richardson's snaggletooth			Stomiidae	STOMIIFORMES
	<i>Bathophilus brevis</i>				Stomiidae	STOMIIFORMES
BTU	<i>Bathophilus digitatus</i>				Stomiidae	STOMIIFORMES
BTN	<i>Bathophilus nigerrimus</i>	Scaleless dragonfish			Stomiidae	STOMIIFORMES
	<i>Bathophilus pawneeii</i>	Pawnee dragonfish			Stomiidae	STOMIIFORMES
	<i>Borostomias elucens</i>				Stomiidae	STOMIIFORMES
BRM	<i>Borostomias mononema</i>	Sickle snaggletooth			Stomiidae	STOMIIFORMES

CUD	<i>Chauliodus danae</i>	Dana viperfish			Stomiidae	STOMIIFORMES
CVS	<i>Chauliodus schmidti</i>				Stomiidae	STOMIIFORMES
CDN	<i>Chauliodus sloani</i>	Sloane's viperfish			Stomiidae	STOMIIFORMES
ECR	<i>Echiostoma barbatum</i>	Threadfin dragonfish			Stomiidae	STOMIIFORMES
	<i>Eustomias achirus</i>	Proud dragonfish			Stomiidae	STOMIIFORMES
	<i>Eustomias dendriticus</i>				Stomiidae	STOMIIFORMES
	<i>Eustomias enbarbatus</i>	Barbate dragonfish			Stomiidae	STOMIIFORMES
	<i>Eustomias filifer</i>				Stomiidae	STOMIIFORMES
	<i>Eustomias lipochirus</i>				Stomiidae	STOMIIFORMES
	<i>Eustomias melanonema</i>				Stomiidae	STOMIIFORMES
	<i>Eustomias melanostigma</i>				Stomiidae	STOMIIFORMES
	<i>Eustomias obscurus</i>				Stomiidae	STOMIIFORMES
FGU	<i>Flagellostomias boureei</i>	Longbarb dragonfish			Stomiidae	STOMIIFORMES
HTO	<i>Heterophotus ophistoma</i>	Wingfin snaggletooth			Stomiidae	STOMIIFORMES
	<i>Leptostomias longibarba</i>				Stomiidae	STOMIIFORMES
MCN	<i>Malacosteus niger</i>	Stoplight loosejaw			Stomiidae	STOMIIFORMES
	<i>Melanostomias bartonbeani</i>	Scaleless black dragonfish			Stomiidae	STOMIIFORMES
MNB	<i>Melanostomias biseriatus</i>				Stomiidae	STOMIIFORMES
MNE	<i>Melanostomias tentaculatus</i>	Tentacle dragonfish			Stomiidae	STOMIIFORMES
	<i>Odontostomias micropogon</i>				Stomiidae	STOMIIFORMES
SCW	<i>Pachystomias microdon</i>	Smalltooth dragonfish			Stomiidae	STOMIIFORMES
	<i>Photonectes dinema</i>				Stomiidae	STOMIIFORMES
	<i>Photonectes leucospilus</i>				Stomiidae	STOMIIFORMES
	<i>Photonectes margarita</i>				Stomiidae	STOMIIFORMES
	<i>Stomias affinis</i>	Günther's boafish			Stomiidae	STOMIIFORMES

	<i>Stomias lampropeltis</i>				Stomiidae	STOMIIFORMES
	<i>Stomias longibarbus</i>	Longbarb scaly dragonfish			Stomiidae	STOMIIFORMES
SWK	<i>Stomias</i> spp				Stomiidae	STOMIIFORMES
	Stomiidae				Stomiidae	STOMIIFORMES
IMB	<i>Ariomma bondi</i>	Silver-rag driftfish			Ariommatidae	STROMATEOIDEI, ANABANTOIDEI
	<i>Ariomma melanum</i>	Brown driftfish	<i>Ariommes nca</i>	<i>Ariomas nep</i>	Ariommatidae	STROMATEOIDEI, ANABANTOIDEI
DRK	<i>Ariomma</i> spp	Driftfishes nei	<i>Ariommes nca</i>	<i>Ariomas nep</i>	Ariommatidae	STROMATEOIDEI, ANABANTOIDEI
HDW	<i>Schedophilus pamarco</i>	Pamarco blackfish	Rouffe rayé	Rufo pamarco	Centrolophidae	STROMATEOIDEI, ANABANTOIDEI
BLB	<i>Stromateus fiatola</i>	Blue butterfish	Fiatole	Palometa fiatola	Stromateidae	STROMATEOIDEI, ANABANTOIDEI
FIP	<i>Fistularia petimba</i>	Red cornetfish	Cornette rouge	Corneta colorada	Fistulariidae	SYNGNATHIFORMES
FIT	<i>Fistularia</i> spp	Flutemouth			Fistulariidae	SYNGNATHIFORMES
FUT	<i>Fistularia tabacaria</i>	Cornetfish	Cornette tachetée	Corneta	Fistulariidae	SYNGNATHIFORMES
	<i>Cosmocampus retropinnis</i>				Syngnathidae	SYNGNATHIFORMES
	<i>Hippocampus algiricus</i>	West African seahorse			Syngnathidae	SYNGNATHIFORMES
	<i>Hippocampus guttulatus</i>	Long-snouted seahorse			Syngnathidae	SYNGNATHIFORMES
HPH	<i>Hippocampus hippocampus</i>	Short snouted seahorse			Syngnathidae	SYNGNATHIFORMES
HIC	<i>Hippocampus</i> spp	Seahorses nei			Syngnathidae	SYNGNATHIFORMES
	<i>Microphis brachyurus aculeatus</i>				Syngnathidae	SYNGNATHIFORMES
	<i>Microphis brachyurus brachyurus</i>	Short-tailed pipefish			Syngnathidae	SYNGNATHIFORMES
SGQ	<i>Syngnathus acus</i>	Greater pipefish			Syngnathidae	SYNGNATHIFORMES
SWY	<i>Syngnathus</i> spp	Pipefishes nei			Syngnathidae	SYNGNATHIFORMES
	<i>Balistes capriscus</i>				Balistidae	TETRAODONTIFORMES
TRG	<i>Balistes carolinensis</i>	Grey triggerfish	Baliste cabri	Pejepuerco blanco	Balistidae	TETRAODONTIFORMES
	<i>Balistes punctatus</i>	Blue spotted			Balistidae	TETRAODONTIFORMES

		triggerfish				
BLV	Balistes vetula	Queen triggerfish			Balistidae	TETRAODONTIFORMES
TRI	Balistidae	Triggerfishes, durgons nei	Balistes nca	Peces-ballesta nep	Balistidae	TETRAODONTIFORMES
CNT	Canthidermis maculatus	Ocean triggerfish			Balistidae	TETRAODONTIFORMES
HJC	Rhinecanthus aculeatus	White-banded triggerfish			Balistidae	TETRAODONTIFORMES
DIY	Diodon hystrix	Spot-fin porcupinefish			Diodontidae	TETRAODONTIFORMES
DIO	Diodontidae	Globefish, porcupine fish	Porcs-epics	Pejerizos, puercoespines	Diodontidae	TETRAODONTIFORMES
MRW	Masturus lanceolatus	Sharptail mola			Molidae	TETRAODONTIFORMES
MOX	Mola mola	Ocean sunfish	Poisson lune	Pez luna	Molidae	TETRAODONTIFORMES
MOP	Mola spp	Sunfish			Molidae	TETRAODONTIFORMES
RZV	Ranzania laevis	Slender sunfish			Molidae	TETRAODONTIFORMES
ALM	Aluterus monoceros	Unicorn leatherjacket filefish			Monacanthidae	TETRAODONTIFORMES
	Aluterus schoepfii	Orange filefishes			Monacanthidae	TETRAODONTIFORMES
ALN	Aluterus scriptus	Scribbled leatherjacket filefi			Monacanthidae	TETRAODONTIFORMES
ALT	Aluterus spp	Leatherjacket filefishes			Monacanthidae	TETRAODONTIFORMES
FFX	Monacanthidae	Filefishes, leatherjackets nei	Poissons-bourses nca	Cachúas, lijas nep	Monacanthidae	TETRAODONTIFORMES
FIK	Stephanolepis hispidus	Planehead filefish		Lija áspera	Monacanthidae	TETRAODONTIFORMES
EFG	Ephippion guttifer	Prickly puffer			Tetraodontidae	TETRAODONTIFORMES
LFL	Lagocephalus laevigatus	Smooth puffer			Tetraodontidae	TETRAODONTIFORMES
LGH	Lagocephalus lagocephalus	Oceanic puffer			Tetraodontidae	TETRAODONTIFORMES
TSP	Sphoeroides pachygaster	Blunthead puffer			Tetraodontidae	TETRAODONTIFORMES
	Sphoeroides spengleri	Bandtail puffer	Compères de l'Atlantique nca	Tamboriles del Atlántico nep	Tetraodontidae	TETRAODONTIFORMES
PUX	Tetraodontidae	Puffers nei	Compères nca	Tamboriles nep	Tetraodontidae	TETRAODONTIFORMES

	Bembrops greyi	Roundtail duckbill			Percophidae	TRACHINOIDEI
	Bembrops heterurus	Squairetail duckbill			Percophidae	TRACHINOIDEI
TRA	Trachinidae	Weeverfishes nei	Vives, etc. nca	Arañas, escorpiones nep	Trachinidae	TRACHINOIDEI
WEX	Trachinus spp	Weevers nei	Vives nca	Arañas nep	Trachinidae	TRACHINOIDEI
	Uranoscopus albesca	Longspine stargazer	Uranoscopes	Miracielos(=Ratas)	Uranoscopidae	TRACHINOIDEI
	Uranoscopus cadenati	West African stargazer	Uranoscopes	Miracielos(=Ratas)	Uranoscopidae	TRACHINOIDEI
	Uranoscopus polli	Whitespotted stargazer	Uranoscopes	Miracielos(=Ratas)	Uranoscopidae	TRACHINOIDEI
URA	Uranoscopus spp	Stargazers	Uranoscopes	Miracielos(=Ratas)	Uranoscopidae	TRACHINOIDEI
ZAC	Antigonia capros	Deepbody boarfish			Caproidae	ZEIFORMES
BOR	Caproidae	Boarfishes nei	Sangliers nca	Ochavos nep	Caproidae	ZEIFORMES
BOC	Capros aper	Boarfish	Sanglier	Ochavo	Caproidae	ZEIFORMES
GMG	Grammicolepis brachiusculus	Thorny tinsel fish			Grammicolepididae	ZEIFORMES
XED	Xenolepidichthys dalgleishi	Spotted tinsel fish			Grammicolepididae	ZEIFORMES
	Allocyttus guineensis				Oreosomatidae	ZEIFORMES
ORD	Oreosomatidae	Oreo dories nei	Oréos nca	Oreós nep	Oreosomatidae	ZEIFORMES
	Cyttopsis rosea	Rosy dory			Parazenidae	ZEIFORMES
ZEX	Zeidae	Dories nei	Saint Pierres nca	Peces de San Pedro nep	Zeidae	ZEIFORMES
JOS	Zenopsis conchifer	Silvery John dory	Saint Pierre argenté	San Pedro plateado	Zeidae	ZEIFORMES
JOD	Zeus faber	John dory	Saint Pierre	Pez de San Pedro	Zeidae	ZEIFORMES
	Zenion hololepis				Zenionidae	ZEIFORMES
MZJ	Zenion longipinnis				Zenionidae	ZEIFORMES
PWR	Pachycara spp				Zoarcidae	ZOARCOIDEI
LVD	Zoarcidae	Eelpouts nei	Loquettes nca	Loquetas nep	Zoarcidae	ZOARCOIDEI
CAR	Chondrichthyes	Cartilaginous fishes nei	Poissons cartilagineux nca	Peces cartilagosos nep		PISCES MISCELLANEA
SKX	Elasmobranchii	Sharks, rays, skates, etc. nei	Requins, raies, etc. nca	Tiburones, rayas, etc. nep		PISCES MISCELLANEA
CYH	Hydrolagus mirabilis	Large-eyed rabbitfish			Chimaeridae	CHIMAERIFORMES
HYD	Hydrolagus spp	Ratfishes nei	Chimères nca	Quimeras nep	Chimaeridae	CHIMAERIFORMES

CNN	Neoharriotta pinnata	Sicklefin chimaera			Rhinochimaeridae	CHIMAERIFORMES
HOL	Chimaeriformes	Chimaeras, etc. nei	Chimères, etc. nca	Quimeras, etc. nep		CHIMAERIFORMES
RSK	Carcharhinidae	Requiem sharks nei	Requins nca	Cazones picudos, tintoreras nep	Carcharhinidae	CARCHARHINIFORMES
CCA	Carcharhinus altimus	Bignose shark	Requin babosse	Tiburón baboso	Carcharhinidae	CARCHARHINIFORMES
CCF	Carcharhinus amboinensis	Pigeye shark	Requin balestrine	Tiburón baleta	Carcharhinidae	CARCHARHINIFORMES
BRO	Carcharhinus brachyurus	Copper shark	Requin cuivre	Tiburón cobrizo	Carcharhinidae	CARCHARHINIFORMES
CCB	Carcharhinus brevipinna	Spinner shark	Requin tisserand	Tiburón aleta negra	Carcharhinidae	CARCHARHINIFORMES
FAL	Carcharhinus falciformis	Silky shark	Requin soyeux	Tiburón jaquetón	Carcharhinidae	CARCHARHINIFORMES
CCE	Carcharhinus leucas	Bull shark	Requin bouledogue	Tiburón sarda	Carcharhinidae	CARCHARHINIFORMES
CCL	Carcharhinus limbatus	Blacktip shark	Requin bordé	Tiburón macuira	Carcharhinidae	CARCHARHINIFORMES
OCS	Carcharhinus longimanus	Oceanic whitetip shark	Requin océanique	Tiburón oceánico	Carcharhinidae	CARCHARHINIFORMES
DUS	Carcharhinus obscurus	Dusky shark	Requin de sable	Tiburón arenero	Carcharhinidae	CARCHARHINIFORMES
CCP	Carcharhinus plumbeus	Sandbar shark	Requin gris	Tiburón trozo	Carcharhinidae	CARCHARHINIFORMES
CCS	Carcharhinus signatus	Night shark	Requin de nuit	Tiburón de noche	Carcharhinidae	CARCHARHINIFORMES
CWZ	Carcharhinus spp	Carcharhinus sharks nei	Requins Carcharhinus nca	Cazones Carcharhinus nep	Carcharhinidae	CARCHARHINIFORMES
TIG	Galeocerdo cuvier	Tiger shark	Requin tigre commun	Tintorera tigre	Carcharhinidae	CARCHARHINIFORMES
NGB	Negaprion brevirostris	Lemon shark	Requin citron	Tiburón galano	Carcharhinidae	CARCHARHINIFORMES
BSH	Prionace glauca	Blue shark	Peau bleue	Tiburón azul	Carcharhinidae	CARCHARHINIFORMES
RHA	Rhizoprionodon acutus	Milk shark	Requin à museau pointu	Cazón lechoso	Carcharhinidae	CARCHARHINIFORMES
HEI	Paragaleus pectoralis	Atlantic weasel shark	Milandre jaune	Tiburón comadiza	Hemigaleidae	CARCHARHINIFORMES
CLL	Leptocharias smithii	Barbeled houndshark	Émissole barbue	Tiburón barbudo	Leptochariidae	CARCHARHINIFORMES
PTM	Pseudotriakis microdon	False catshark	Requin à longue dorsale	Musolón de aleta larga	Pseudotriakidae	CARCHARHINIFORMES
SHO	Galeus melastomus	Blackmouth catshark	Chien espagnol	Pintarroja bocanegra	Scyliorhinidae	CARCHARHINIFORMES

GAQ	Galeus polli	African sawtail catshark	Chien râpe	Pintarroja africana	Scyliorhinidae	CARCHARHINIFORMES
GAU	Galeus spp	Crest-tail catsharks nei	Chiens galeus nca	Pintarrojas nep	Scyliorhinidae	CARCHARHINIFORMES
SYX	Scyliorhinidae	Catsharks, etc. nei	Chiens, holbiches, rouss et. nca	Alitanes, pejegatos, p intar. nep	Scyliorhinidae	CARCHARHINIFORMES
SYC	Scyliorhinus canicula	Small-spotted catshark	Petite roussette	Pintarroja	Scyliorhinidae	CARCHARHINIFORMES
SYE	Scyliorhinus cervigoni	West African catshark	Roussette thalassa	Alitán africano	Scyliorhinidae	CARCHARHINIFORMES
SCL	Scyliorhinus spp	Catsharks, nursehounds nei	Roussettes nca	Alitanes, pintarrojas nep	Scyliorhinidae	CARCHARHINIFORMES
SYT	Scyliorhinus stellaris	Nursehound	Grande roussette	Alitán	Scyliorhinidae	CARCHARHINIFORMES
SPV	Sphyrna couardi	Whitefin hammerhead	Requin-marteau aile blanche	Cornuda aliblanca	Sphyrnidae	CARCHARHINIFORMES
SPL	Sphyrna lewini	Scalloped hammerhead	Requin-marteau halicorne	Cornuda común	Sphyrnidae	CARCHARHINIFORMES
SPK	Sphyrna mokarran	Great hammerhead	Grand requin marteau	Cornuda gigante	Sphyrnidae	CARCHARHINIFORMES
SPN	Sphyrna spp	Hammerhead sharks nei	Requins marteau nca	Cornudas (Peces martillo) nep	Sphyrnidae	CARCHARHINIFORMES
SPZ	Sphyrna zygaena	Smooth hammerhead	Requin-marteau commun	Cornuda cruz(=Pez martillo)	Sphyrnidae	CARCHARHINIFORMES
SPY	Sphyrnidae	Hammerhead sharks, etc. nei	Requins marteau, etc. nca	Cornudas, etc. nep	Sphyrnidae	CARCHARHINIFORMES
GAG	Galeorhinus galeus	Tope shark	Requin-hâ	Cazón	Triakidae	CARCHARHINIFORMES
SMD	Mustelus mustelus	Smooth-hound	Émissole lisse	Musola	Triakidae	CARCHARHINIFORMES
TRK	Triakidae	Houndsharks, smooth hounds nei	Émissoles, requins-hâ nca	Cazones, tollos nep	Triakidae	CARCHARHINIFORMES
CVX	Carcharhiniformes	Ground sharks				CARCHARHINIFORMES
HXT	Heptranchias perlo	Sharpnose sevengill shark	Requin perlon	Cañabota bocadulce	Hexanchidae	HEXANCHIFORMES
SBL	Hexanchus griseus	Bluntnose sixgill shark	Requin grisset	Cañabota gris	Hexanchidae	HEXANCHIFORMES
HXW	Hexanchiformes	Friiled and cow sharks				HEXANCHIFORMES
THR	Alopias spp	Thresher sharks nei	Renards de mer nca	Zorros nep	Alopiidae	LAMNIFORMES
BTH	Alopias superciliosus	Bigeye thresher	Renard à gros yeux	Zorro ojón	Alopiidae	LAMNIFORMES

ALV	<i>Alopias vulpinus</i>	Thresher	Renard	Zorro	Alopiidae	LAMNIFORMES
BSK	<i>Cetorhinus maximus</i>	Basking shark	Pèlerin	Peregrino	Cetorhinidae	LAMNIFORMES
WSH	<i>Carcharodon carcharias</i>	Great white shark	Grand requin blanc	Jaquetón blanco	Lamnidae	LAMNIFORMES
SMA	<i>Isurus oxyrinchus</i>	Shortfin mako	Taupe bleue	Marrajo dientuso	Lamnidae	LAMNIFORMES
MAK	<i>Isurus spp</i>	Mako sharks	Taupes	Marrajos	Lamnidae	LAMNIFORMES
POR	<i>Lamna nasus</i>	Porbeagle	Requin-taupe commun	Marrajo sardinero	Lamnidae	LAMNIFORMES
MSK	Lamnidae	Mackerel sharks, porbeagles nei	Requins taupe nca	Jaquetones, marrajos nep	Lamnidae	LAMNIFORMES
LMP	<i>Megachasma pelagios</i>	Megamouth shark	Requin grande gueule	Tiburón bocudo	Megachasmidae	LAMNIFORMES
LMO	<i>Mitsukurina owstoni</i>	Goblin shark	Requin lutin	Tiburón duende	Mitsukurinidae	LAMNIFORMES
CCT	<i>Carcharias taurus</i>	Sand tiger shark	Requin taureau	Toro bacota	Odontaspidae	LAMNIFORMES
LMZ	Lamniformes	Mackerel sharks				LAMNIFORMES
GNC	<i>Ginglymostoma cirratum</i>	Nurse shark	Requin-nourrice	Gata nodriza	Ginglymostomidae	ORECTOLOBIFORMES
RHN	<i>Rhincodon typus</i>	Whale shark	Requin baleine	Tiburón ballena	Rhincodontidae	ORECTOLOBIFORMES
DCA	<i>Deania calcea</i>	Birdbeak dogfish	Squale savate	Tollo pajarito	Centrophoridae	SQUALIFORMES
SDU	<i>Deania profundorum</i>	Arrowhead dogfish	Squale-savate lutin	Tollo flecha	Centrophoridae	SQUALIFORMES
SCK	<i>Dalatias licha</i>	Kitefin shark	Squale liche	Carocho	Dalatiidae	SQUALIFORMES
SHB	<i>Echinorhinus brucus</i>	Bramble shark	Squale bouclé	Tiburón de clavos	Echinorhinidae	SQUALIFORMES
OXY	<i>Oxynotus centrina</i>	Angular roughshark	Centrine commune	Cerdo marino	Oxynotidae	SQUALIFORMES
OXN	<i>Oxynotus paradoxus</i>	Sailfin roughshark	Humantin	Cerdo marino velero	Oxynotidae	SQUALIFORMES
SYO	<i>Scymnodon obscurus</i>	Smallmouth knifetooth dogfish	Squale-grogneur à queue échan.	Bruja bocachica	Somniosidae	SQUALIFORMES
SYR	<i>Scymnodon ringens</i>	Knifetooth dogfish	Squale-grogneur commun	Bruja	Somniosidae	SQUALIFORMES
GUP	<i>Centrophorus granulosus</i>	Gulper shark	Squale-chagrin commun	Quelvacho	Squalidae	SQUALIFORMES
CPL	<i>Centrophorus lusitanicus</i>	Lowfin gulper shark	Squale-chagrin longue dorsale	Quelvacho lusitanico	Squalidae	SQUALIFORMES
CWO	<i>Centrophorus spp</i>	Gulper sharks nei	Squales-chagrins nca	Quelvachos nep	Squalidae	SQUALIFORMES
GUQ	<i>Centrophorus squamosus</i>	Leafscale gulper shark	Squale-chagrin de l'Atlantique	Quelvacho negro	Squalidae	SQUALIFORMES
CFB	<i>Centroscyllium fabricii</i>	Black dogfish	Aiguillat noir	Tollo negro merga	Squalidae	SQUALIFORMES

CYO	Centroscymnus coelolepis	Portuguese dogfish	Pailona commun	Pailona	Squalidae	SQUALIFORMES
CYY	Centroscymnus cryptacanthus	Shortnose velvet dogfish	Pailona sans épine	Pailona ñata	Squalidae	SQUALIFORMES
CZI	Centroscymnus spp				Squalidae	SQUALIFORMES
DNA	Deania spp	Deania dogfishes nei	Squales-savates nca	Tollos deania nep	Squalidae	SQUALIFORMES
ETT	Etmopterus polli	African lanternshark	Sagre à menton lisse	Tollo lucero africano	Squalidae	SQUALIFORMES
ETP	Etmopterus pusillus	Smooth lanternshark	Sagre nain	Tollo lucero liso	Squalidae	SQUALIFORMES
ETX	Etmopterus spinax	Velvet belly	Sagre commun	Negrito	Squalidae	SQUALIFORMES
SHL	Etmopterus spp	Lanternsharks nei	Sagres nca	Tollos lucero nep	Squalidae	SQUALIFORMES
DGX	Squalidae	Dogfish sharks nei	Squales nca	Galludos, tollos, nep	Squalidae	SQUALIFORMES
DGS	Squalus acanthias	Picked dogfish	Aiguillat commun	Mielga	Squalidae	SQUALIFORMES
QUB	Squalus blainvillei	Longnose spurdog	Aiguillat coq	Galludo	Squalidae	SQUALIFORMES
DOP	Squalus megalops	Shortnose spurdog	Aiguillat nez court	Galludo ñato	Squalidae	SQUALIFORMES
QUK	Squalus mitsukurii	Shortspine spurdog	Aiguillat épinette	Galludo espinilla	Squalidae	SQUALIFORMES
DGZ	Squalus spp	Dogfishes nei	Aiguillats nca	Mielgas nep	Squalidae	SQUALIFORMES
CPU	Squalus uyato	Little gulper shark	Petit squale-chagrin	Galludito	Squalidae	SQUALIFORMES
SUA	Squatina aculeata	Sawback angelshark	Ange de mer épineux	Angelote espinudo	Squatinae	SQUALIFORMES
SUT	Squatina oculata	Smoothback angelshark	Ange de mer ocellé	Pez ángel	Squatinae	SQUALIFORMES
ASK	Squatinae	Angelsharks, sand devils nei	Anges de mer nca	Angelotes, peces ángel nep	Squatinae	SQUALIFORMES
SHX	Squaliformes	Dogfish sharks, etc. nei	Squaliformes nca	Squaliformes nep		SQUALIFORMES
BAI	Batoidimorpha(Hypotr emata)	Batoid fishes nei	Batoïdes nca	Peces batoideos nep		PISCES MISCELLANEA
STT	Dasyatidae	Stingrays, butterfly rays nei	Pastenagues, etc. nca	Pastinacas, etc. nep	Dasyatidae	RAJIFORMES
RDC	Dasyatis centroura	Roughtail stingray			Dasyatidae	RAJIFORMES
RDS	Dasyatis margarita	Daisy stingray			Dasyatidae	RAJIFORMES
RDE	Dasyatis margaritella	Pearl stingray			Dasyatidae	RAJIFORMES
RDQ	Dasyatis marmorata	Marbled stingray			Dasyatidae	RAJIFORMES
JDP	Dasyatis pastinaca	Common stingray	Pastenague commune	Raya látigo común	Dasyatidae	RAJIFORMES
RTB	Taeniura grabata	Round stingray			Dasyatidae	RAJIFORMES
RUA	Urogymnus	Porcupine ray			Dasyatidae	RAJIFORMES

	asperrimus					
RGL	Gymnura altavela	Spiny butterfly ray	Raie-papillon épineuse	Raya mariposa	Gymnuridae	RAJIFORMES
RGI	Gymnura micrura	Smooth butterfly ray			Gymnuridae	RAJIFORMES
RBV	Gymnura spp	Butterfly rays nei	Raies-papillon nca	Rayas mariposa nep	Gymnuridae	RAJIFORMES
RMC	Mobula coilloti				Mobulidae	RAJIFORMES
RMM	Mobula mobular	Devil fish		Manta mobula	Mobulidae	RAJIFORMES
	Mobula rancurelli				Mobulidae	RAJIFORMES
RMN	Mobula rochebrunei	Lesser Guinean devil ray	Petit diable de Guinée	Diablito de Guinea	Mobulidae	RAJIFORMES
RMV	Mobula spp	Mobula nei			Mobulidae	RAJIFORMES
RMO	Mobula thurstoni	Smoothtail mobula			Mobulidae	RAJIFORMES
MAN	Mobulidae	Mantas, devil rays nei	Mantes, diables de mer nca	Mantas, diablos nep	Mobulidae	RAJIFORMES
MAF	Aetobatus flagellum	Longheaded eagle ray			Myliobatidae	RAJIFORMES
MAE	Aetobatus narinari	Spotted eagle ray	Aigle de mer léopard	Chucho pintado	Myliobatidae	RAJIFORMES
AQX	Aetobatus spp				Myliobatidae	RAJIFORMES
EAG	Myliobatidae	Eagle rays nei	Aigles de mer nca	Aguilas de mar nep	Myliobatidae	RAJIFORMES
MYL	Myliobatis aquila	Common eagle ray	Aigle commun	Aguila marina	Myliobatidae	RAJIFORMES
MWX	Myliobatis spp				Myliobatidae	RAJIFORMES
MPO	Pteromylaeus bovinus	Bull ray			Myliobatidae	RAJIFORMES
MRB	Rhinoptera bonasus	Cownose ray			Myliobatidae	RAJIFORMES
MRM	Rhinoptera marginata	Lusitanian cownose ray			Myliobatidae	RAJIFORMES
	Rhinoptera spp.				Myliobatidae	RAJIFORMES
RMB	Manta birostris	Giant manta			Myliobatidae	RAJIFORMES
SAW	Pristidae	Sawfishes	Poissons-scies	Peces sierra	Pristidae	RAJIFORMES
RPM	Pristis microdon	Large tooth sawfish			Pristidae	RAJIFORMES
RPP	Pristis pectinata	Small tooth sawfish			Pristidae	RAJIFORMES
RPR	Pristis pristis	Common sawfish			Pristidae	RAJIFORMES
BYH	Bathyraja hesperaficana	West African skate			Rajidae	RAJIFORMES
BHY	Bathyraja spp	Bathyraja rays nei	Raies bathyraja nca	Rayas bathyraja nep	Rajidae	RAJIFORMES

RJB	Dipturus batis	Blue skate	Pocheteau gris	Noriega	Rajidae	RAJIFORMES
JFD	Dipturus doutrei	Violet skate			Rajidae	RAJIFORMES
RJO	Dipturus oxyrinchus	Longnosed skate	Pocheteau noir	Raya picuda	Rajidae	RAJIFORMES
JFX	Leucoraja leucosticta	Whitedappled skate			Rajidae	RAJIFORMES
RJN	Leucoraja naevus	Cuckoo ray	Raie fleurie	Raya santiguesa	Rajidae	RAJIFORMES
RNA	Neoraja africana	West African pygmy skate			Rajidae	RAJIFORMES
RJC	Raja clavata	Thornback ray	Raie bouclée	Raya de clavos	Rajidae	RAJIFORMES
JAI	Raja miraletus	Brown ray	Raie miroir	Raya de espejos	Rajidae	RAJIFORMES
JAR	Raja radula	Rough ray			Rajidae	RAJIFORMES
RFX	Raja rouxi				Rajidae	RAJIFORMES
SKA	Raja spp	Raja rays nei	Pocheteaux et raies raja nca	Rayas raja nep	Rajidae	RAJIFORMES
RFL	Raja straeleni	Spotted skate			Rajidae	RAJIFORMES
RJU	Raja undulata	Undulate ray	Raie brunette	Raya mosaica	Rajidae	RAJIFORMES
JFV	Rajella leopardus	Leopard skate			Rajidae	RAJIFORMES
RAJ	Rajidae	Rays and skates nei	Rajidés nca	Rayidos nep	Rajidae	RAJIFORMES
RJA	Rostroraja alba	White skate; bottlenose skate	Raie blanche	Raya bramante	Rajidae	RAJIFORMES
GTF	Rhinobatidae	Guitarfishes, etc. nei	Guitares, etc. nca	Guitarras, etc. nep	Rhinobatidae	RAJIFORMES
GUB	Rhinobatos albomaculatus	Whitespotted guitarfish	Poisson-guitare à lunaires	Guitarra pecosa	Rhinobatidae	RAJIFORMES
RHH	Rhinobatos blochii	Bluntnose guitarfish			Rhinobatidae	RAJIFORMES
RBC	Rhinobatos cemiculus	Blackchin guitarfish			Rhinobatidae	RAJIFORMES
RBI	Rhinobatos irvinei	Spineback guitarfish			Rhinobatidae	RAJIFORMES
RBX	Rhinobatos rhinobatos	Common guitarfish			Rhinobatidae	RAJIFORMES
GUZ	Rhinobatos spp	Guitarfishes nei	Guitares nca	Guitarras nep	Rhinobatidae	RAJIFORMES
RCL	Rhynchobatus luebberti	African wedgefish			Rhinobatidae	RAJIFORMES
RZS	Zanobatus schoenleinii	Striped panray			Rhinobatidae	RAJIFORMES
SRX	Rajiformes	Rays, stingrays, mantas nei	Raies, pastenagues, mantes nca	Rayas, pastinacas, mantas nep		RAJIFORMES
TOD	Torpedinidae	Electric rays nei	Torpilles, raies électriq. nca	Tremielgas, torpedos nep	Torpedinidae	TORPEDINIFORMES

TTB	Torpedo bauchotae	Rosette torpedo			Torpedinidae	TORPEDINIFORMES
TTN	Torpedo mackayana	Ringed torpedo			Torpedinidae	TORPEDINIFORMES
TTR	Torpedo marmorata	Marbled electric ray; spotted torpedo;	Torpille marbrée	Tremolina mármol	Torpedinidae	TORPEDINIFORMES
TTO	Torpedo nobiliana	Electric ray	Torpille noire	Tremolina negra	Torpedinidae	TORPEDINIFORMES
TOE	Torpedo spp	Torpedo rays	Torpilles	Tremolinas	Torpedinidae	TORPEDINIFORMES
TTV	Torpedo torpedo	Common torpedo	Torpille ocellée	Tremolina	Torpedinidae	TORPEDINIFORMES

Invertebrates (includes plants & garbage)

CODE	Scientific_name	English_name	French_name	Spanish_name	Family	Order
X1		<i>Garbage - everything except plastic</i>				
X1		<i>Rubbish - everything except plastic</i>				
X2		<i>Garbage - Plastic material</i>				
X2		<i>Plastic material</i>				
X2		<i>Rubbish - Plastic material</i>				
NUQ	Anomura	Anomuran decapods nei	Décapodes anomura nca	Decápodos anomura nep		ANOMURA
GGW	Gorgoniidae	Gorgonians			Gorgoniidae	ANTHOZOA
ATX	Actiniaria	Sea anemones	Actinies	Anémonas de mar		ANTHOZOA
AJZ	Alcyonacea	Soft corals	Corails mous	Corales muelles		ANTHOZOA
AJH	Anthozoa	Corals, anemones, nei				ANTHOZOA
CBL	Non-Scleractinia	Soft corals nei	Corails mous nca	Corales muelles nep		ANTHOZOA
NTW	Pennatulacea	Sea pens				ANTHOZOA
CSS	Scleractinia	Hard corals, madrepores nei	Madrépores nca	Madréporas nep		ANTHOZOA
SSX	Ascidiacea	Sea squirts nei	Ascidiens nca	Ascidas nep		ASCIDIACEA
STF	Asteroidea	Starfishes nei	Astéridés nca	Estrellas nep		ASTEROIDEA
OUK	Alloteuthis africana	African squid	Casseron africain	Calamarín africano	Loliginidae	CEPHALOPODA
OCT	Octopodidae	Octopuses, etc. nei	Pieuvres, poulpes nca	Pulpitos, pulpos nep	Octopodidae	CEPHALOPODA

OQD	Octopus defilippi	Lilliput longarm octopus	Poulpe à longs bras	Pulpito patilargo	Octopodidae	CEPHALOPODA
OCN	Octopus macropus	White-spotted octopus	Poulpe tacheté	Pulpo patudo	Octopodidae	CEPHALOPODA
OCC	Octopus vulgaris	Common octopus	Pieuvre	Pulpo común	Octopodidae	CEPHALOPODA
SQM	Illex coindetii	Broadtail shortfin squid	Encornet rouge	Pota voladora	Ommastrephidae	CEPHALOPODA
EJB	Sepia bertheloti	African cuttlefish	Seiche africaine	Sepia africana	Sepiidae	CEPHALOPODA
EJE	Sepia elegans	Elegant cuttlefish	Seiche élégante	Sepia elegante	Sepiidae	CEPHALOPODA
EJL	Sepia elobyana	Guinean cuttlefish	Seiche de Guinée	Sepia guineana	Sepiidae	CEPHALOPODA
CTC	Sepia officinalis	Common cuttlefish	Seiche commune	Sepia común	Sepiidae	CEPHALOPODA
IAR	Sepia orbignyana	Pink cuttlefish	Seiche rosée	Sepia con punta	Sepiidae	CEPHALOPODA
IAX	Sepia spp	Cuttlefishes nei	Seiches nca	Sepias nep	Sepiidae	CEPHALOPODA
IEO	Sepiella ornata	Ornate cuttlefish	Sépia ornée	Sepia ornada	Sepiidae	CEPHALOPODA
HHP	Heteroteuthis dispar	Odd bobtail squid	Sépiole différente	Globito aberrante	Sepiolidae	CEPHALOPODA
CEP	Cephalopoda	Cephalopods nei	Céphalopodes nca	Cefalópodos nep		CEPHALOPODA
CTL	Sepiidae, Sepiolidae	Cuttlefish, bobtail squids nei	Seiches, sépioles nca	Sepias, choquitos, globitos nep		CEPHALOPODA
CWD	Crinoidea	Feather stars and sea lilies	Crinoïdes	Crinoideos		CRINOIDEA
CRU	Crustacea	Marine crustaceans nei	Crustacés marins nca	Crustáceos marinos nep		CRUSTACEA MISCELLANEA
SPO	Spongidae	Sponges	Éponges	Esponjas	Spongidae	DEMOSPONGIAE
ECH	Echinodermata	Echinoderms	Oursins, bèches-de-mer	Erizos, cohombros de mar		ECHINODERMATA
URX	Echinoidea	Sea urchins, sand dollars, etc. nei	Oursins, etc. nca	Erizos, etc. nep		ECHINOIDEA
YBC	Cymbium cymbium	Pig's snout volute	Volute trompe de cochon	Voluta trompa de cerdo	Volutidae	GASTROPODA
YBG	Cymbium glans	Elephant's snout volute	Volute trompe d'éléphant	Voluta trompa de elephante	Volutidae	GASTROPODA
YBP	Cymbium pepo	Neptune's volute	Volute Neptune	Voluta de Nepruno	Volutidae	GASTROPODA
CXY	Cymbium spp	Volutes nei	Volutes nca	Volutas nep	Volutidae	GASTROPODA
GAS	Gastropoda	Gastropods nei	Gastropodes nca	Gasterópodos nep		GASTROPODA
CUX	Holothurioidea	Sea cucumbers nei	Bèches-de-mer nca	Cohombros de mar nep		HOLOTHURIOIDEA
HQZ	Hydrozoa	Hydrozoans	Hydrozoaires	Hidrozoos		HYDROZOA
CNI	Cnidaria	Cnidarians nei	Cnidaires nca	Cnidarios nep		INVERTEBRATA AQUATICA

						MISCELL.
INV	Invertebrata	Aquatic invertebrates nei	Invertébrés aquatiques nca	Invertebrados acuáticos nep		INVERTEBRATA AQUATICA MISCELL.
ISH	Isopoda	Isopods, pillbugs, sowbugs				ISOPODA
MSH	Ex Mollusca	Marine shells nei	Coquilles marines nca	Conchas marinas nep		MOLLUSCA MISCELLANEA
MOL	Mollusca	Marine molluscs nei	Mollusques marins nca	Moluscos marinos nep		MOLLUSCA MISCELLANEA
OWP	Ophiuroidea	Basket and brittle stars	Ophiures	Ofiuroideos		OPHIUROIDEA
WOR	Polychaeta	Marine worms	Vers marins	Poliquetos		POLYCHAETA
PWJ	Pycnogonida	Sea spiders				PYCNOGONIDA
CZP	Callianassa spp	Ghost shrimps			Callianassidae	REPTANTIA
NEX	Nephropidae	True lobsters, lobsterettes nei	Homards, langoustines nca	Bogavantes, cigalas nep	Nephropidae	REPTANTIA
VLO	Palinuridae	Spiny lobsters nei	Langoustes diverses nca	Langostas diversas nep	Palinuridae	REPTANTIA
SLC	Panulirus argus	Caribbean spiny lobster	Langouste blanche	Langosta común del Caribe	Palinuridae	REPTANTIA
LOY	Panulirus regius	Royal spiny lobster	Langouste royale	Langosta real	Palinuridae	REPTANTIA
SLV	Panulirus spp	Tropical spiny lobsters nei	Langoustes tropicales nca	Langostas tropicales nep	Palinuridae	REPTANTIA
LOS	Scyllaridae	Slipper lobsters nei	Cigales nca	Cigarros nep	Scyllaridae	REPTANTIA
YLK	Scyllarides herklotsii	Red slipper lobster	Cigale rouge	Cigarro rojo	Scyllaridae	REPTANTIA
LOX	Reptantia	Lobsters nei	Langoustes, homards nca	Langostas nep		REPTANTIA
LQH	Lysiosquilla hoevenii	Lizard mantis	Squille lézard géante	Galera gigante	Lysiosquillidae	STOMATOPODA
QLA	Squilla aculeata	Kicking mantis shrimp	Squille frappeuse	Galera pateadora	Squillidae	STOMATOPODA
QLC	Squilla cadenati	Angolan mantis srimp	Squille angolaise	Galera de Angola	Squillidae	STOMATOPODA
MTS	Squilla mantis	Spottail mantis squillid	Squille ocellée	Galera ocelada	Squillidae	STOMATOPODA
SQY	Squillidae	Squillids nei	Squilles nca	Galeras nep	Squillidae	STOMATOPODA
SVX	Stomatopoda	Stomatopods nei	Stomatopodes nca	Estomatopodos nep		STOMATOPODA
CLX	Bivalvia	Clams, etc. nei	Clams, etc. nca	Almejas, etc. nep		BIVALVIA
KAR	Calappa rubroguttata	Spotted box crab	Migraine maculée	Calapa manchada	Calappidae	BRACHYURA
SCR	Maja squinado	Spinous spider crab	Araignée européenne	Centolla europea	Majidae	BRACHYURA

UCG	<i>Uca tangeri</i>	West african fiddler crab	Gelasime africain	Violinista africano	Ocypodidae	BRACHYURA
KLM	<i>Callinectes amnicola</i>	Bigfisted swimcrab	Crabe bicorne	Cangrejo tijeron	Portunidae	BRACHYURA
KLG	<i>Callinectes marginatus</i>	Marbled swimcrab	Crabe marbré	Cangrejo jaspeado	Portunidae	BRACHYURA
KLP	<i>Callinectes pallidus</i>	Gladiator swimcrab	Crabe gladiateur	Cagrejo gladiator	Portunidae	BRACHYURA
CAL	<i>Callinectes</i> spp	Swimcrabs nei	Crabes nca	Jaibas nep	Portunidae	BRACHYURA
KNR	<i>Cronius ruber</i>	Red swimcrab	Crabe rouge	Cangrejo colorado	Portunidae	BRACHYURA
SWM	Portunidae	Swimming crabs, etc. nei	Crabes, étrilles nca	Jaibas, etc. nep	Portunidae	BRACHYURA
OSQ	<i>Portunus hastatus</i>	Lancer swimcrab	Étrille nageuse	Jaiba cornuda	Portunidae	BRACHYURA
CRS	<i>Portunus</i> spp	Portunus swimcrabs nei	Étrilles nca	Jaibas, nécoras nep	Portunidae	BRACHYURA
PVQ	<i>Portunus validus</i>	Senegalese smooth swimcrab	Étrille lisse du Sénégal	Jaiba satinada	Portunidae	BRACHYURA
CRA	Brachyura	Marine crabs nei	Crabes de mer nca	Cangrejos de mar nep		BRACHYURA
ARV	<i>Aristeus varidens</i>	Striped red shrimp	Gambon rayé	Gamba listada	Aristaeidae	NATANTIA
SSH	<i>Plesiopenaeus edwardsianus</i>	Scarlet shrimp	Gambon écarlate	Gamba carabinero	Aristaeidae	NATANTIA
CRN	Crangonidae	Crangonid shrimps nei	Crevettes crangonidés nca	Camarones crangónidos nep	Crangonidae	NATANTIA
ONZ	<i>Pontocaris lacazei</i>	Hardshell shrimp	Crevette crâne	Camarón de casco	Crangonidae	NATANTIA
XHH	<i>Exhippolysmata hastadoides</i>	Companion shrimp	Bouc compagnon	Camarón compañero	Hippolytidae	NATANTIA
NCF	<i>Nematocarcinus africanus</i>	African spider shrimp	Crevette araignée d'Afrique	Camarón araña africano	Nematocarcinidae	NATANTIA
NLH	<i>Nematopalaemon hastatus</i>	West African estuarine prawn	Bouquet étier	Camarón estuarino africano	Palaemonidae	NATANTIA
PAL	Palaemonidae	Palaemonid shrimps nei	Crevettes palémonides nca	Camarones palemónidos nep	Palaemonidae	NATANTIA
HKF	<i>Heterocarpus ensifer</i>	Armed nylon shrimp	Crevette nylon armée	Camarón nylon armado	Pandalidae	NATANTIA
PDZ	Pandalidae	Pandalid shrimps nei	Crevettes pandalides nca	Camarones pandálidos nep	Pandalidae	NATANTIA
PVJ	<i>Parapandalus narval</i>	Narwal shrimp	Crevette narval	Camarón narval	Pandalidae	NATANTIA
LKT	<i>Plesionika martia</i>	Golden shrimp	Crevette dorée	Camarón de oro	Pandalidae	NATANTIA
GFU	<i>Glyphus marsupialis</i>	Kangaroo shrimp	Sivade kangourou	Camarón canguro	Pasiphaeidae	NATANTIA
GUS	<i>Parapenaepsis atlantica</i>	Guinea shrimp	Crevette guinéenne	Camarón guineo	Penaeeidae	NATANTIA
DPS	<i>Parapenaeus longirostris</i>	Deep-water rose shrimp	Crevette rose du large	Gamba de altura	Penaeeidae	NATANTIA

PEZ	Penaeidae	Penaeid shrimps nei	Crevettes pénéidés nca	Camarones peneídos nep	Penaeidae	NATANTIA
TGS	Penaeus kerathurus	Caramote prawn	Caramote	Langostino	Penaeidae	NATANTIA
SOP	Penaeus notialis	Southern pink shrimp	Crevette rose du Sud	Camarón rosado sureño	Penaeidae	NATANTIA
YIA	Sicyonia carinata	Mediterranean rock shrimp	Boucot méditerranéen	Camarón de piedra mediterráneo	Sicyoniidae	NATANTIA
YIG	Sicyonia galeata	Tufted rock shrimp	Sicyonie huppée	Camarón penachudo	Sicyoniidae	NATANTIA
SKF	Solenocera africana	African mud shrimp	Solenocère d'Afrique	Camarón fanguero africano	Solenoceridae	NATANTIA
SOZ	Solenoceridae	Solenocerid shrimps nei	Salicoques, solénocères nca	Camarones solenoceros nep	Solenoceridae	NATANTIA
DCP	Natantia	Natantian decapods nei	Décapodes natantia nca	Decápodos natantia nep		NATANTIA
APL	Plantae aquaticae	Aquatic plants nei	Plantes aquatiques nca	Plantas acuáticas nep		PLANTAE AQUATICAE MISCELLANEA

Marine Mammals

CODE	Scientific_name	English_name	French_name	Spanish_name	Family	Order
MAM	Mammalia	Aquatic mammals unid.	Mammifères aquatiques nca	Mamíferos acuáticos nep		MAMMALIA Unid.
EUA	Eubalaena australis	Southern right whale	Baleine australe	Ballena franca austral	Balaenidae	MYSTICETI
MIW	Balaenoptera acutorostrata	Minke whale	Petit rorqual	Rorcual enano	Balaenopteridae	MYSTICETI
BFW	Balaenoptera bonaerensis	Antarctic minke whale	Petit rorqual antarctique	Rorcual antártico	Balaenopteridae	MYSTICETI
SIW	Balaenoptera borealis	Sei whale	Rorqual de Rudolphi	Rorcual del Norte	Balaenopteridae	MYSTICETI
BRW	Balaenoptera brydei (also B. edeni)	Bryde's whale	Rorqual de Bryde	Rorcual tropical	Balaenopteridae	MYSTICETI
BRW	Balaenoptera edeni (see B.brydei)	Bryde's whale	Rorqual de Bryde	Rorcual tropical	Balaenopteridae	MYSTICETI
BLW	Balaenoptera musculus	Blue whale	Rorqual bleu	Ballena azul	Balaenopteridae	MYSTICETI
FIW	Balaenoptera physalus	Fin whale	Rorqual commun	Rorcual común	Balaenopteridae	MYSTICETI
BAE	Balaenopteridae	Balaenoptid whales unid.		Rorcuales nep	Balaenopteridae	MYSTICETI
HUW	Megaptera novaeangliae	Humpback whale	Baleine à bosse	Rorcual jorobado	Balaenopteridae	MYSTICETI
CPM	Caperea marginata	Pygmy right whale	Baleine pygmée	Ballena franca pigmea	Neobalaenidae	MYSTICETI

MYS	Mysticeti	Baleen whales unid.	Baleines mysticètes nca	Ballenas mysticetas nep		MYSTICETI
HVD	Cephalorhynchus heavisidii	Heaviside's dolphin	Dauphin d'Heaviside	Delfin de Heaviside	Delphinidae	ODONTOCETI
DLP	Delphinidae	Dolphins unid.	Dauphins nca	Delfinidos nep	Delphinidae	ODONTOCETI
DCZ	Delphinus capensis	Long-beaked common dolphin	Dauphin commun a bec large	Delfin común a pico largo	Delphinidae	ODONTOCETI
DCO	Delphinus delphis	Common dolphin	Dauphin commun	Delfin común	Delphinidae	ODONTOCETI
KPW	Feresa attenuata	Pygmy killer whale	Orque pygmée	Orca pigmea	Delphinidae	ODONTOCETI
SHW	Globicephala macrorhynchus	Short-finned pilot whale	Globicéphale tropical	Calderón de aletas cortas	Delphinidae	ODONTOCETI
PIW	Globicephala melas	Long-finned pilot whale	Globicéphale commun	Calderón común	Delphinidae	ODONTOCETI
GLO	Globicephala spp	Pilot whales unid.			Delphinidae	ODONTOCETI
DRR	Grampus griseus	Risso's dolphin	Grampus	Delfin de Risso	Delphinidae	ODONTOCETI
FRD	Lagenodelphis hosei	Fraser's dolphin	Dauphin de Fraser	Delfin de Fraser	Delphinidae	ODONTOCETI
DDU	Lagenorhynchus obscurus	Dusky dolphin	Dauphin sombre	Delfin obscuro	Delphinidae	ODONTOCETI
RSW	Lissodelphis peronii	Southern right whale dolphin	Dauphin aptère austral	Delfin liso austral	Delphinidae	ODONTOCETI
KIW	Orcinus orca	Killer whale	Orque	Orca	Delphinidae	ODONTOCETI
MEW	Peponocephala electra	Melon-headed whale	Péponocéphale	Calderón pequeño	Delphinidae	ODONTOCETI
FAW	Pseudorca crassidens	False killer whale	Faux-orque	Orca falsa	Delphinidae	ODONTOCETI
DHA	Sousa teuszii	Atlantic hump-backed dolphin	Dauphin à bosse de l'Atlantiq.	Delfin jorobado del Atlántico	Delphinidae	ODONTOCETI
DPN	Stenella attenuata	Pantropical spotted dolphin	Dauphin tacheté pantropical	Estenela moteada	Delphinidae	ODONTOCETI
DCL	Stenella clymene	Clymene dolphin	Dauphin de Clyméné	Delfin clymene	Delphinidae	ODONTOCETI
DST	Stenella coeruleoalba	Striped dolphin	Dauphin bleu et blanc	Estenela listada	Delphinidae	ODONTOCETI
DSA	Stenella frontalis	Atlantic spotted dolphin	Dauphin tacheté de l'Atlantiq.	Delfin pintado	Delphinidae	ODONTOCETI
DSI	Stenella longirostris	Spinner dolphin	Dauphin longirostre	Estenela giradora	Delphinidae	ODONTOCETI
DSP	Stenella spp	Spotted dolphins unid.	Dauphins tachetés nca	Estenelas nep	Delphinidae	ODONTOCETI
RTD	Steno bredanensis	Rough-toothed dolphin	Sténo	Esteno	Delphinidae	ODONTOCETI
DBO	Tursiops truncatus	Bottlenose dolphin	Grand dauphin	Tursion	Delphinidae	ODONTOCETI
PYW	Kogia breviceps	Pygmy sperm whale	Cachalot pygmée	Cachalote pigmeo	Kogiidae	ODONTOCETI
DWW	Kogia sima	Dwarf sperm whale	Cachalot nain	Cachalote enano	Kogiidae	ODONTOCETI
SPW	Physeter catodon (P.	Sperm whale	Cachalot	Cachalote	Physeteridae	ODONTOCETI

	macrocephalus)					
BAW	Berardius arnuxii	Arnoux's beaked whale	Béradien d'Arnoux	Ballenato de Arnoux	Ziphiidae	ODONTOCETI
SRW	Hyperoodon planifrons	Southern bottlenose whale	Hyperoodon austral	Ballena nariz de botella sur	Ziphiidae	ODONTOCETI
BBW	Mesoplodon densirostris	Blainville's beaked whale	Baleine à bec de Blainville	Zifio de Blainville	Ziphiidae	ODONTOCETI
BGW	Mesoplodon europaeus	Gervais' beaked whale	Baleine à bec de Gervais	Zifio de Gervais	Ziphiidae	ODONTOCETI
BYW	Mesoplodon grayi	Gray's beaked whale	Baleine à bec de Gray	Zifio de Gray	Ziphiidae	ODONTOCETI
BHW	Mesoplodon hectori	Hector's beaked whale	Baleine à bec d'Hector	Zifio de Hector	Ziphiidae	ODONTOCETI
TSW	Mesoplodon layardii	Strap-toothed whale	Baleine à bec de Layard	Zifio de Layard	Ziphiidae	ODONTOCETI
BTW	Mesoplodon mirus	True's beaked whale	Baleine à bec de True	Zifio de True	Ziphiidae	ODONTOCETI
MEP	Mesoplodon spp	Beaked whales unid.			Ziphiidae	ODONTOCETI
BSW	Tasmacetus shepherdi	Sherpherd's beaked whale	Tasmacète	Ballena picuda de Shepherd	Ziphiidae	ODONTOCETI
BCW	Ziphius cavirostris	Cuvier's beaked whale	Ziphius	Zifio de Cuvier	Ziphiidae	ODONTOCETI
ODN	Odontoceti	Toothed whales unid.	Baleines odontocètes nca	Ballenas odontocetas nep		ODONTOCETI
SEF	Arctocephalus australis	South American fur seal	Otarie d'Amérique du Sud	Lobo fino austral	Otariidae	PINNIPEDIA
SEK	Arctocephalus pusillus	South African fur seal	Otarie du Cap	Lobo marino de dos pelos	Otariidae	PINNIPEDIA
SSF	Arctocephalus tropicalis	Subantarctic fur seal	Otarie sub-antarctique	Lobo fino de subantarctico	Otariidae	PINNIPEDIA
SEL	Otaria byronia	South American sea lion	Lion de mer d'Amérique du Sud	Lobo común	Otariidae	PINNIPEDIA
SMM	Monachus monachus	Mediterranean monk seal	Phoque moine de Méditerranée	Foca monje del Mediterráneo	Phocidae	PINNIPEDIA
SXX	Otariidae, Phocidae	Seals unid.	Phoques nca	Focas nep		PINNIPEDIA
WAM	Trichechus senegalensis	West African manatee	Lamantin d'Afrique	Vaca marina del Africa	Trichechidae	SIRENIA

Marine Turtles

CODE	Scientific_name	English_name	French_name	Spanish_name	Family	Order
TTL	Caretta caretta	Loggerhead turtle	Caouane	Caguama	Cheloniidae	TESTUDINES

TUG	Chelonia mydas	Green turtle	Tortue verte	Tortuga verde	Cheloniidae	TESTUDINES
TTH	Eretmochelys imbricata	Hawksbill turtle	Tortue caret	Tortuga carey	Cheloniidae	TESTUDINES
LKV	Lepidochelys olivacea	Olive ridley turtle	Tortue olivatre	Tortuga golfina	Cheloniidae	TESTUDINES
DKK	Dermochelys coriacea	Leatherback turtle	Tortue luth	Tortuga laud	Dermochelyidae	TESTUDINES
TTX	Testudinata	Marine turtles nei	Tortues de mer nca	Tortugas de mar nep		TESTUDINES

Seabirds

CODE	Scientific_name	English_name	French_name	Spanish_name	Family	Order
LRD	Laridae	Gulls nei			Laridae	CHARADRIIFORMES
SVZ	Sterna spp	Terns nei			Laridae	CHARADRIIFORMES
SZV	Sulidae	Boobies and gannets nei			Sulidae	CICONIIFORMES
PRX	Procellariidae	Petrels and shearwaters nei			Procellariidae	PROCELLARIIFORMES

Appendix 8. International and National Fishing Boundaries – Gulf of Guinea

Need map of Gulf of Guinea region with national boundaries
National EEZs

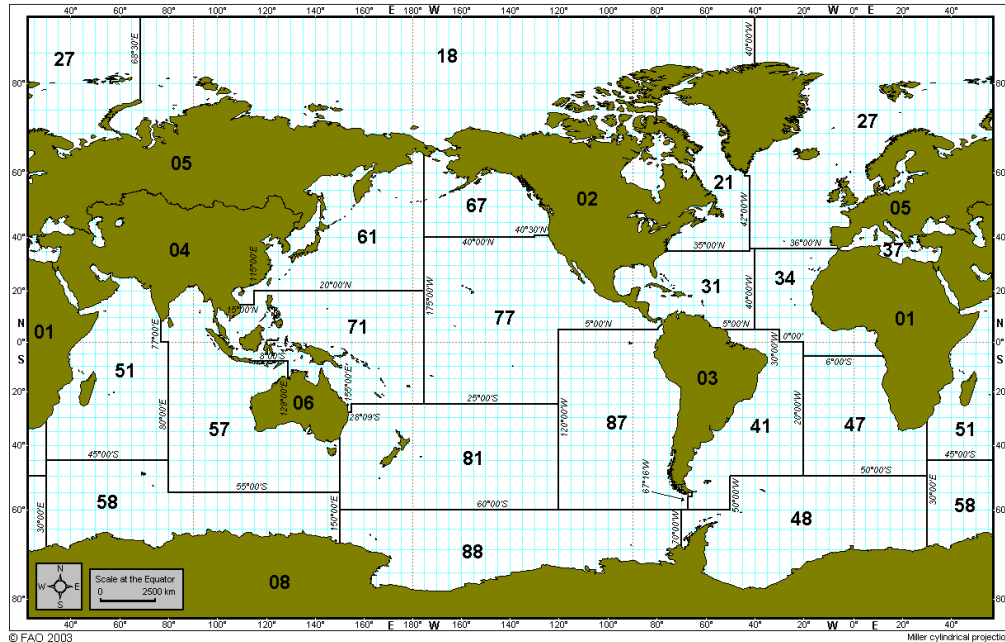

FAO Statistical Areas

Appendix 9. Map of African Time Zones

Map of African time zones indicating difference from UTC. Map from www.wikipedia.org.

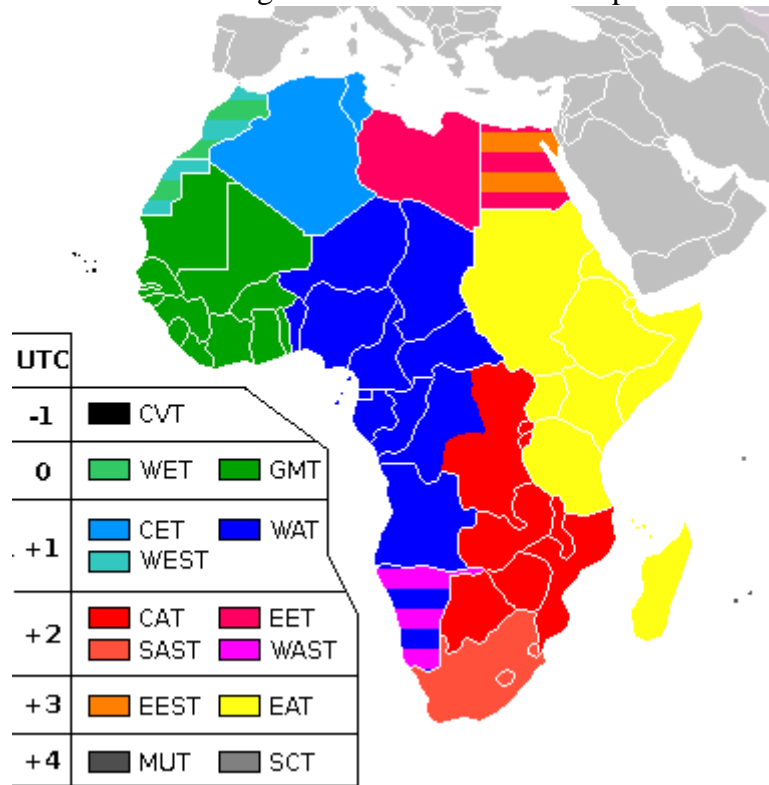

Appendix 10. Common Formulas & Conversion Factors

Abbreviations

Fathoms	f	Metric ton	mt	Latitude	lat
Nautical miles	Nm	Kilogram	kg	Longitude	long
Kilometer	km	Gram	g	Fahrenheit	°F
Meter	m			Celsius	°C
Centimeter	cm	Hour	hr	Knot	Kn
Millimeter	mm	Minute	min	Meters/second	m/s
Liter	L			Radius	r

Common Conversions

Speed

1 knot = 1 nautical mile per hour = 1.852
km/hr = 0.514 m/s

Distance / length

1 nautical mile = 1 min lat = 1.852 km =
1,012.6859 fathoms
1 degree (latitude) = 60 nautical miles
1 fathom = 1.829 meter
1 meter = 100 cm
1 cm = 10 mm
1000 m = 1 km

Weight

1 mt = 1,000 kg
1 kg = 1000 g

Volume

1 L = 1.0567 U.S. qt

Temperature

$F^{\circ} = (1.8 \times C^{\circ}) + 32$
 $C^{\circ} = (F^{\circ} - 32) \times .555$

Area and Volume Formulas

Area of a circle = πr^2 ($\pi = 3.1416$)

Circumference = $2 \pi r$

Area of a square or rectangle = length * width

Area of a triangle = $\frac{1}{2} * \text{base} * \text{height}$

Volume of a right angle cone = $\frac{1}{3} * \pi r^2 h$

Volume of a Sphere = $\frac{4}{3} * \pi * r^3$

Length of the triangle hypotenuse "C" where A and B equal the length of the opposite two sides: $a^2 + b^2 = c^2$ and $\sqrt{c} = c$

Volumetric Formulas:

V = Volume
H = Height
L = Length
W = Width
 $\pi = 3.1416$
D = Diameter
d = diameter
R = Radius

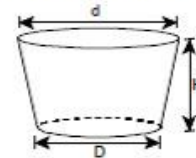
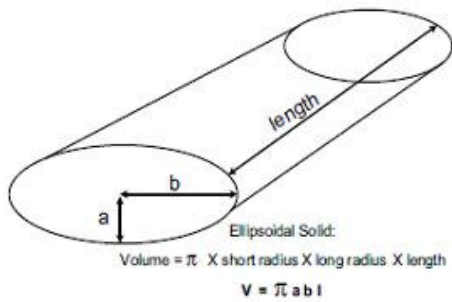
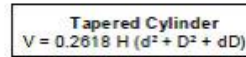
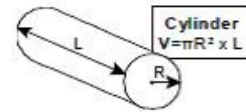
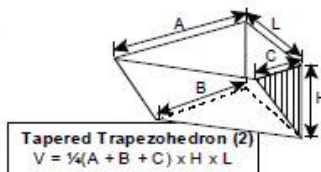
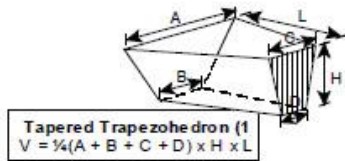
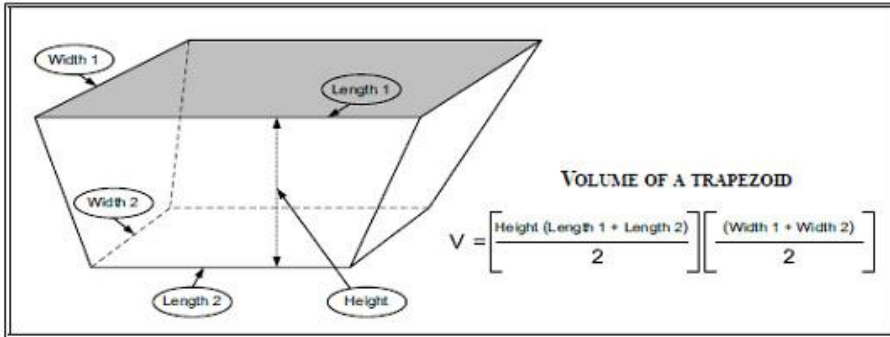
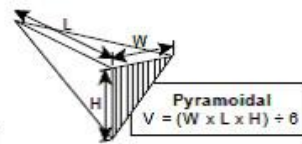
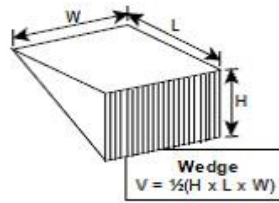
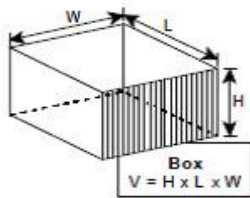

Appendix 11. Random Number Tables

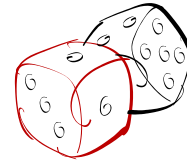

How to Use the Random Number Table

To use the random number table, enter the table at a random point. The easiest way to do this is by closing your eyes and placing your finger on the table. The column and row nearest your finger is the starting point. Determine how many digits in the row you are using: if you need numbers between 1 and 250, use three digits in the row. If you need numbers between 1 and 25, use two digits in the row, and so on. Decide in which direction you will move through the table. Then proceed in any direction through the table (even diagonally), recording appropriate numbers and skipping numbers too high or repeated, until you have enough random numbers. You should decide on a direction and enter the table at a different random starting point every time you use it.

For example, if you need to choose 3 numbers between 1 and 25, you could enter the table by placing your finger on the table to choose a column and row. Your criterion is two digit numbers between 01 and 25 (inclusive). For this example, you decided to work up the column from your starting point. As you move up the column, the first number you encounter is 14. This is a two-digit number between 01 and 25; it fits the criterion, so you write it down. The next number is 09; it also fits the criterion, so you write it down. The next number is 58 and does not fit the criterion so you skip this number. Keep moving up the column, skipping the numbers that do not fit the criterion, until you choose the all the numbers you need.

Random Number Table

1 6 7 8 6	3 9 2 3 6	7 3 5 2 1	5 8 3 8 5	1 1 2 7 9
2 0 8 2 7	2 4 3 9 9	5 3 5 3 7	3 5 7 3 8	0 0 7 2 4
1 5 8 5 1	0 6 2 8 8	7 3 1 3 0	7 5 2 7 8	8 4 0 2 7
3 0 3 9 8	5 0 9 4 4	4 9 1 7 0	6 9 5 8 5	7 4 0 3 7
9 9 6 4 7	1 2 6 5 6	7 6 4 5 2	6 8 0 8 5	7 1 4 0 6
6 5 3 0 1	5 1 4 0 2	8 3 4 8 9	8 3 5 7 9	0 8 3 3 4
8 8 8 4 6	3 8 0 0 6	4 1 5 6 5	2 1 4 9 1	1 8 7 9 3
7 7 2 2 2	1 8 4 9 5	8 0 1 4 5	4 2 2 9 9	9 4 6 3 0
3 8 6 0 1	9 5 8 7 5	0 5 7 0 0	8 1 7 3 2	1 0 6 2 8
1 7 6 6 3	0 9 3 3 2	3 0 9 7 8	4 1 4 6 7	7 2 4 3 2
8 9 6 4 8	8 9 1 2 7	7 3 9 5 5	4 1 4 1 4	4 1 0 5 6
4 0 7 5 3	1 8 9 4 0	8 3 1 3 0	9 3 6 4 1	5 6 1 4 0
7 1 5 2 0	8 1 8 1 4	3 6 2 0 8	4 9 4 0 2	7 1 9 4 1
8 1 6 8 7	3 6 6 3 7	3 6 3 8 1	4 5 4 0 4	5 5 6 4 5
8 9 9 2 9	2 4 3 7 3	2 5 4 0 4	6 6 5 0 2	5 7 2 7 6
2 2 6 7 3	2 3 8 4 7	6 1 7 6 6	1 4 4 0 4	0 2 9 7 6
4 6 3 6 9	3 0 5 0 2	4 4 3 2 3	1 7 6 4 9	7 0 3 6 2
4 6 0 4 5	6 9 3 9 1	2 5 9 2 9	5 3 8 6 5	5 7 2 1 6
1 6 5 0 3	6 0 1 7 1	2 2 5 2 5	9 1 2 1 4	1 2 2 7 7
4 7 3 3 5	8 1 8 8 3	9 7 9 5 4	8 8 8 3 3	5 5 2 4 0
5 3 9 8 8	2 0 9 5 4	3 2 9 5 3	4 2 1 0 0	1 3 7 7 9
7 7 1 5 2	8 0 6 8 6	3 2 6 1 3	5 6 3 8 5	8 4 1 8 4
9 5 2 9 3	2 0 3 7 8	4 9 4 6 9	3 5 6 1 0	1 7 2 9 3
4 0 6 4 6	6 6 2 5 8	2 6 7 0 1	4 4 8 4 4	3 4 5 5 1
7 1 6 0 3	0 1 8 0 5	0 9 0 0 8	5 3 5 5 0	5 6 8 3 2
5 2 0 8 7	3 0 5 4 2	1 1 3 7 0	3 1 1 5 9	7 5 9 8 5
1 4 7 1 0	6 6 8 0 1	1 7 9 7 6	5 9 2 2 5	2 7 2 6 7
7 6 8 6 3	9 6 3 0 6	3 6 7 4 5	7 7 0 8 4	7 3 3 7 2
3 6 4 1 9	8 7 5 2 4	0 8 4 8 6	4 1 5 4 3	9 7 1 1 6
9 3 6 5 4	1 0 0 1 8	1 0 6 4 1	3 8 5 1 5	0 0 8 0 4
1 8 4 9 7	9 5 5 1 1	8 7 8 1 0	7 5 2 9 6	1 3 0 4 4
5 1 8 4 9	8 1 4 7 5	8 0 7 4 6	1 4 0 8 9	7 7 3 1 8
5 5 0 6 1	0 9 8 7 7	0 7 9 5 7	6 1 5 1 1	6 0 0 5 3
6 9 9 7 3	6 9 6 5 9	2 0 7 3 9	2 7 5 3 3	1 0 3 1 0
5 3 6 6 6	4 5 2 5 1	6 2 0 2 7	1 8 7 8 8	8 9 5 5 4
3 0 0 9 1	1 5 9 7 3	6 9 3 9 1	4 0 4 3 9	1 1 0 2 8
8 2 9 0 2	3 8 8 9 8	8 8 8 1 5	7 5 8 1 5	9 7 8 8 5
2 9 7 8 4	1 3 4 6 9	7 9 6 7 9	1 5 0 2 7	9 3 5 0 2
0 8 7 0 7	2 2 8 8 6	5 3 1 4 1	4 2 5 0 1	4 8 6 9 5
6 3 7 4 4	2 7 5 0 7	8 8 0 7 0	7 3 2 3 2	9 4 9 8 4

Appendix 12. Sea State

Beau- fort	Wind Speed (kn)	Wave Height (m)	Description	SPECIFICATIONS FOR USE AT SEA
0	0-1	0	Calm	Sea like a mirror
1	1-3	.1	Light Air	Ripples with the appearance of scales are formed, but without foam crests.
2	4-6	.2	Light Breeze	Small wavelets, still short, but more pronounced. Crests have a glassy appearance and do not break.
3	7-10	.6	Gentle Breeze	Large wavelets. Crests begin to break. Foam of glassy appearance. Perhaps scattered white horses.
4	11-16	1	Moderate Breeze	Small waves, becoming larger; fairly frequent white horses.
5	17-21	2	Fresh Breeze	Moderate waves, taking a more pronounced long form; many white horses are formed. Chance of some spray.
6	22-27	3	Strong Breeze	Large waves begin to form; the white foam crests are more extensive everywhere. Probably some spray.
7	28-33	4	Near Gale	Sea heaps up and white foam from breaking waves begins to be blown in streaks along the direction of the wind.
8	34-40	5.5	Gale	Moderately high waves of greater length; edges of crests begin to break into spindrift. The foam is blown in well-marked streaks along the direction of the wind.
9	41-47	7	Severe Gale	High waves. Dense streaks of foam along the direction of the wind. Crests of waves begin to topple, tumble and roll over. Spray may affect visibility.
10	48-55	9	Storm	Very high waves with long over-hanging crests. The resulting foam, in great patches, is blown in dense white streaks along the direction of the wind. On the whole the surface of the sea takes on a white appearance. The 'tumbling' of the sea becomes heavy and shock-like. Visibility affected.
11	56-63	11.5	Violent Storm	Exceptionally high waves (small and medium-size ships might be for a time lost to view behind the waves). The sea is completely covered with long white patches of foam lying along the direction of the wind. Everywhere the edges of the wave crests are blown into froth. Visibility affected.
12	64-71	14+	Hurricane	The air is filled with foam and spray. Sea completely white with driving spray; visibility very seriously affected.

Appendix 13. Standard Phonetic Alphabet

Letter	Word	Pronunciation
A	Alfa	AL FAH
B	Bravo	BRAH VOH
C	Charlie	CHAR LEE
D	Delta	DELL TAH
E	Echo	ECK OH
F	Foxtrot	FOKS TROT
G	Golf	GOLF
H	Hotel	HOH TELL
I	India	IN DEE AH
J	Juliet	JOO LEE ETT
K	Kilo	KEY LOW
L	Lima	LEE MAH
M	Mike	MIKE
N	November	NO VEM BER
O	Oscar	OSS CAR
P	Papa	PA PAH
Q	Quebec	KWE BECK
R	Romeo	ROW ME OH
S	Sierra	SEE AIR RAH
T	Tango	TANG GO
U	Uniform	YOU NEE FORM
V	Victor	VIK TUR
W	Whiskey	WISS KEY
X	X-ray	ECKS RAY
Y	Yankee	YANG KEY
Z	Zulu	ZOO LOO

Appendix 14. International Conventions Signed by West African Nations

(Source: International Maritime Organization, Status of Conventions by Country, downloaded August 15, 2009)

	IMO Convention 48	IMO amendments 91	IMO amendments 93	SOLAS Convention 74	SOLAS Protocol 78	SOLAS Protocol 88	Stockholm Agreement 96	LOAD LINES Convention 66	LOAD LINES Protocol 88	TONNAGE Convention 69	COLREG Convention 72	CSC Convention 72	CSC amendments 93	SFV Protocol 93	STCW Convention 78	STCW-F Convention 95	SAR Convention 79	STP Agreement 71	STP Protocol 73	INMARSAT Convention 76	INMARSAT OA 76	INMARSAT amendments 94	INMARSAT amendments 98	IMSO amendments 2006	FACILITATION Convention 65	MARPOL 73/78 (Annex I/II)	MARPOL 73/78 (Annex III)	MARPOL 73/78 (Annex IV)	MARPOL 73/78 (Annex V)	MARPOL Protocol 97 (Annex VI)	London Convention 72	London Convention Protocol 96	INTERVENTION Convention 69		
Angola	X			X	X			X		X	X	X			X		X								X	X	X	X	X			X	X		
Benin	X	X		X	X			X		X	X	X			X		X									X	X	X	X	X			X	X	
Burkina Faso																																			
Cameroon	X	X		X				X			X				X		X				X	X				X								X	
Cape Verde	X		X	X				X		X	X	X			X		X									X	X	X	X	X		X			
Chad																																			
Conqo	X	X	X	X				X		X	X				X		X									X	X	X	X	X					
Cote d'Ivoire	X	X	X	X	X			X		X	X				X		X									X	X	X	X	X		X		X	
Dem. Rep. of the Conqo	X			X				X			X				X		X									X	X	X	X	X		X			
Equatorial Guinea	X			X	X	X		X	X	X	X				X											X	X	X	X	X		X		X	
Gabon	X	X		X				X		X	X				X						X	X	X			X	X	X	X	X		X		X	
Gambia	X	X	X	X				X		X	X				X		X				X	X	X			X	X	X	X	X					
Guinea	X			X	X			X		X	X	X			X											X	X	X	X	X					
Guinea-Bissau	X																																		
Liberia	X	X	X	X	X	X		X	X	X	X	X		X	X		X			X	X		X		X	X	X	X	X	X				X	
Mali																																			
Mauritania	X			X	X			X		X	X				X	X										X	X	X	X					X	
Namibia	X	X	X	X	X			X	X	X	X				X	X	X										X	X	X	X					X
Niger																																			
Nigeria	X	X	X	X				X		X	X	X			X		X				X	X		X		X	X	X	X	X		X		X	
Senegal	X	X		X	X			X		X	X				X		X				X	X		X		X	X	X	X					X	
Sierra Leone	X	X	X	X	X	X		X	X	X	X				X	X										X	X	X	X	X	X	X	X	X	
Togo	X	X		X	X			X		X	X				X											X	X	X	X						

	INTERVENTION Protocol 73	CLC Convention 69	CLC Protocol 76	CLC Protocol 92	FUND Convention 71	FUND Protocol 76	FUND Protocol 92	FUND Protocol 2003	NUCLEAR Convention 71	PAL Convention 74	PAL Protocol 76	PAL Protocol 90	PAL Protocol 02	LLMC Convention 76	LLMC Protocol 96	SUA Convention 88	SUA Protocol 88	SUA Convention 2005	SUA Protocol 2005	SALVAGE Convention 89	OPRC Convention 90	HNS Convention 96	OPRC/HNS 2000	BUNKERS CONVENTION 01	ANTI FOULING 01	BALLASTWATER 2004	NAIROBI WRC 2007	HONG KONG SRC 2009
Angola																												
Benin		x			x									x		x	x				x	x						
Burkina Faso																x	x											
Cameroon		d	x	x	x		x																					
Cape Verde				x			x									x	x				x							
Chad																												
Conqo				x			x							x						x	x							
Cote d'Ivoire		x			x																							
Dem. Rep. of the Conqo																												
Equatorial Guinea		x								x				x		x	x											
Gabon		d		x	x		x		x												x							
Gambia		x			x																							
Guinea				x			x									x	x			x	x							
Guinea-Bissau																x	x											
Liberia		x	d	x	x	d	x	x		x	x	x		x	x	x	x			x	x	x	x	x	x	x		
Mali																x	x											
Mauritania		x	x	x		x										x	x				x							
Namibia		x			x		x									x	x				x							
Niager																x	x											
Nigeria		d		x	x		x			x			x		x					x	x					x	x	
Senegal		x												x		x	x				x							
Sierra Leone		d		x	d		x							x	x					x	x	x		x	x	x		
Togo																x	x											

Appendix 15. CITES Listed Marine Vertebrates – Southern & West Africa

Compiled from <http://www.cites.org/eng/app/appendices.shtml>. Accessed January 15, 2010.

Appendix I – Most endangered. Trade in specimens of Appendix I species is normally prohibited, and may be allowed in exceptional circumstances when the purpose of the import is not commercial, for instance, for scientific research.

Marine Mammals

Southern right whale	<i>Eubalaena australis</i>
Minke whale	<i>Balaenoptera acutorostrata</i>
Antarctic minke whale	<i>Balaenoptera bonaerensis</i>
Sei whale	<i>Balaenoptera borealis</i>
Bryde's whale	<i>Balaenoptera byrdei (edeni)</i>
Blue whale	<i>Balaenoptera musculus</i>
Fin whale	<i>Balaenoptera physalus</i>
Humpback whale	<i>Megaptera novaeangliae</i>
Pygmy right whale	<i>Caperea marginata</i>
Atlantic hump-backed dolphin	<i>Sousa teuszii</i>
Sperm whale	<i>Physeter catodon (P. macrocephalus)</i>
Arnoux's beaked whale	<i>Berardius arnuxii</i>
Southern bottlenose whale	<i>Hyperoodon planifrons</i>
Mediterranean monk seal	<i>Monachus monachus</i>

Sea turtles

Leatherback turtle	<i>Dermochelys coriacea</i>
Loggerhead turtle	<i>Caretta caretta</i>
Green turtle	<i>Chelonia mydas</i>
Hawksbill turtle	<i>Eretmochelys imbricata</i>
Olive ridley turtle	<i>Lepidochelys olivacea</i>

Fish

Sturgeon	<i>Acipenser sturio</i>
Smalltooth sawfish	<i>Pristis pectinata</i>
Common sawfish	<i>Pristis pristis</i>

Appendix II – At serious risk. Includes species that are not necessarily threatened with extinction now but may become so unless trade is closely controlled. It also includes so-called “look-alike” species, i.e. species similar in appearance to the species listed for conservation reasons. Trade in Appendix II specimens is only allowed if certain conditions are met, above all that the trade level will not be detrimental to the survival of the species in the wild.

Marine Mammals

Short-finned pilot whale	<i>Globicephala macrorhynchus</i>
Long-finned pilot whale	<i>Globicephala melas</i>
Risso's dolphin	<i>Grampus griseus</i>
Fraser's dolphin	<i>Lagenodelphis hosei</i>
Dusky dolphin	<i>Lagenorhynchus obscurus</i>
Southern right whale dolphin	<i>Lissodelphis peronii</i>
Killer whale	<i>Orcinus orca</i>
Melon-headed whale	<i>Peponocephala electra</i>

False killer whale	<i>Pseudorca crassidens</i>
Pantropical spotted dolphin	<i>Stenella attenuata</i>
Clymene dolphin	<i>Stenella clymene</i>
Striped dolphin	<i>Stenella coeruleoalba</i>
Atlantic spotted dolphin	<i>Stenella frontalis</i>
Spinner dolphin	<i>Stenella longirostris</i>
Rough-toothed dolphin	<i>Steno bredanensis</i>
Bottlenose dolphin	<i>Tursiops truncatus</i>
Pygmy sperm whale	<i>Kogia breviceps</i>
Dwarf sperm whale	<i>Kogia sima</i>
Blainville's beaked whale	<i>Mesoplodon densirostris</i>
Gervais' beaked whale	<i>Mesoplodon europaeus</i>
Gray's beaked whale	<i>Mesoplodon grayi</i>
Hector's beaked whale	<i>Mesoplodon hectori</i>
Strap-toothed whale	<i>Mesoplodon layardii</i>
True's beaked whale	<i>Mesoplodon mirus</i>
Beaked whales nei	<i>Mesoplodon spp</i>
Sherpherd's beaked whale	<i>Tasmacetus shepherdi</i>
Cuvier's beaked whale	<i>Ziphius cavirostris</i>
South American fur seal	<i>Arctocephalus australis</i>
South African fur seal	<i>Arctocephalus pusillus</i>
Subantarctic fur seal	<i>Arctocephalus tropicalis</i>
West African manatee	<i>Trichechus senegalensis</i>
Fish (incl. sharks)	
Great white shark	<i>Carcharodon carcharias</i>
Basking shark	<i>Cetorhinus maximus</i>
Whale shark	<i>Rhincodon typus</i>
Seahorses	<i>Hippocampus spp.</i>

Appendix III - includes species that are protected in at least one country, which has asked other CITES Parties for assistance in controlling the trade.

Appendix 16. Glossary / Acronyms

Abeam – at right angles to the keel of the boat, but not on the boat.

Acoustic Doppler Current Profiler¹ (ADCP or ADP) - sonar that attempts to produce a record of water current velocities for a range of depths.

Aft - Toward the stern of the boat (on the boat); opposite of forward.

Ahead – In front of the boat; opposite of astern

AIS – see Automatic Identification System

Apex⁴ - The section of the backdown channel during a purse seine set furthest from the ship, where the corkline sinks during backdown to allow marine mammals to escape.

Argos system - Satellite-based location and data collection system dedicated to studying the environment, developed as a result of French-American cooperation between the Centre National d'Etudes Spatiales (CNES, the French space agency), the National Aeronautics and Space Administration (NASA, USA) and the National Oceanic and Atmospheric Administration (NOAA, USA). See also: <http://www.argos-system.org>.

Artisanal Fisheries - Small-scale and local fisheries carried out by people who rely on fishing to support their families and communities. Generally subsistence and/or only partly commercial in nature.

Astern - Behind of the boat, opposite of ahead.

Athwartship – across or at right angles to the center line of a boat.

Automatic Identification System¹ (AIS) - a short range coastal tracking system used on ships and by Vessel Traffic Services (VTS) for identifying and locating vessels by electronically exchanging data with other nearby ships and VTS stations. IMO SOLAS requires on vessels > 300 GRT and all passenger vessels regardless of size.

Backdown⁴ - The principal marine mammal release maneuver. The vessel starts to reverse after approximately two-thirds of the net has been rolled aboard and is tied down. This causes the corkline at the apex of the channel formed by the net to sink, thus allowing captured marine mammals to escape without losing the tuna catch.

Batten down - Secure hatches and loose objects both within the hull and on deck.

Beam - vessel width at its widest point.

Bearing - The direction of an object expressed either as a true bearing as shown on the chart, or as a bearing relative to the heading of the boat.

Bight - The part of the rope or line, between the end and the standing part, on which a knot is formed.

Bilge - The interior of the hull below the floor boards.

Bird radar⁴ - A very sensitive, high-resolution radar capable of detecting flocks of birds at distances of up to 15 miles.

Bow - The forward part of a boat.

Brailer³ - net used for transferring the catch of a deep sea seine after it has been brought alongside. It is operated either entirely by hand or partly by hand and partly by power.

BRD – see bycatch reduction device

Branchline – Line connecting a hook to mainline of longline gear.

Breezer – school of fish (yellowtail or tuna usually) swimming close enough to surface to cause what looks like a breeze on the water.

Bridge - The location from which a vessel is steered and its speed controlled.

Bulkhead - A vertical partition separating compartments (a wall).

Bycatch - The parts of a fishery catch containing non-targeted species (including fish, birds or marine mammals) and often discarded at sea.

Bycatch reduction device (BRD) - A device used to allow live escapement of unwanted species or individuals (juveniles) or endangered species.

Bunt – see Sack

Cabin - A compartment for passengers or crew.

Catch Documentation Scheme (CDS) – formal protocol to document fisheries catch and sometimes products

CECAF - FAO Fishery Committee for the Eastern Central Atlantic

Capsize - To turn over.

Capstan³ –consists of one vertically-mounted warping head. Used for hauling ropes, it has the advantage that it can take ropes coming from any horizontal direction without the need for guiding blocks and other rope leading systems, provided that the rope is perpendicular to the capstan shaft and approximately on the same horizontal plane as the warping head.

CDS – see Catch Documentation Scheme

Chart - A map for use by navigators.

Chase⁴ - Pursuing marine mammals with the intention of herding them and setting around them. A chase commences when the first speedboat is launched. Occasionally the seiner will do the chasing, usually in sets on whales.

CSW - Circulating Sea Water; See RSW

Codend – terminal end of a trawl net used to hold fish

Course - The direction in which a boat is steered.

Current - The horizontal movement of water.

Davit - any of various crane-like devices used singly or in pairs for supporting, raising, and lowering esp. boats, anchors, and cargo over a hatchway or side of a ship

Deck - A permanent covering over a compartment, hull or any part thereof.

Demersal – Living / found at or near the bottom of a body of water: e.g. a demersal fish

Derrick¹ – a lifting device composed of one mast or pole which is hinged freely at the bottom. It is controlled by lines (usually four of them) powered by some means such as man-hauling or motors, so that the pole can move in all four directions. A line runs up it and over its top with a hook on the end.

Dolphin Safety Panel (system)⁴ - A small-mesh net strip installed in place of the standard 4¹/₄"-mesh strip, beginning 75 to 100 fathoms from the bow ortza and extending towards the stern end of the net. When correctly installed and aligned, it covers the perimeter of the backdown channel, and reduces the likelihood of marine mammal entanglement. Safety panels were originally made of 2" mesh webbing (Medina panel), but are now made of 1¹/₄" mesh webbing (fine-mesh panel).

DWFN – Distant Water Fishing Nations

Draft¹ (or **draught**) - the vertical distance between the waterline and the bottom of the hull (keel), with the thickness of the hull included.

Ducted propeller – see Kort nozzle

Echo sounder¹ - the technique of using sound pulses directed from the surface or from a submarine vertically down to measure the distance to the bottom by means of sound waves. Device may also be referred to as a depth sounder.

EEZ – see Exclusive Economic Zone

Emergency Position-Indicating Radio Beacon (EPIRB) – One component of a GMDSS.

Exclusive Economic Zone³ (EEZ) - A zone under national jurisdiction (up to 200-nautical miles wide) declared in line with the provisions of 1982 United Nations Convention of the Law of the Sea, within which the coastal State has the right to explore and exploit, and the responsibility to conserve and manage, the living and non-living resourcesj.

eXpendable BathyThermograph (XBT) - a temperature and depth probe that is launched from the bridge wing of a ship using a hand launcher.

FAD – see fish aggregating device

FAO - Food and Agriculture Organization of the United Nations

Fender - A cushion, placed between boats, or between a boat and a pier, to prevent damage.

Fish-Aggregating Device⁴ - There are two types of FAD: those designed and deployed with the sole purpose of attracting fish, or those improvised by fishermen from natural flotsam (a tree trunk, for instance) to which they attach anything that will make it more attractive to the fish.

Flags of Convenience (FoC) - Vessels use the flags of states that either cannot or do not apply and enforce regulations. Countries such as Panama operate an open registry, and make a business from granting flags to foreign owned vessels.

Forepeak - A compartment in the bow of a small boat.

Forward – Toward the front of the boat (on the boat); opposite aft.

Galley - The kitchen area of a boat.

Gangion – see branchline

GCLME - Guinea Current Large Marine Ecosystem

GDP - Gross Domestic Product

Global Maritime Distress Safety System¹ (GMDSS) - an internationally agreed-upon set of safety procedures, types of equipment, and communication protocols used to increase safety and make it easier to rescue distressed ships, boats and aircraft.

Global Positioning System (GPS) –

GMDSS – see Global Maritime Distress Safety System

GPS –see Global Positioning System

Gross register tonnage¹ (**GRT**; also **grt, g.r.t.**) represents the total internal volume of a vessel, with some exemptions for non-productive spaces. A gross register ton is equal to a volume of 100 cubic feet (~2.83 m³).

Gross tonnage¹ - (**GT**; also **G.T., gt**) is a unitless index related to a ship's overall internal volume. Gross Tonnage is different from Gross Register Tonnage. Neither Gross Tonnage nor Gross Register Tonnage are measures of the ship's displacement (mass) and should not be confused with terms such as deadweight tonnage, net tonnage, or displacement. Gross Tonnage is calculated by measuring a ship's volume (from keel to funnel, to the outside of the hull framing) and applying a mathematical formula.

GT – see gross tonnage

GRT – see gross register tonnage

Hatch - An opening in a boat's deck fitted with a watertight cover.

Hanging ratio - the length of a rope on which a net panel is mounted divided by the actual length of stretched netting on the rope

Head - A marine toilet.

Hull - The main body of a vessel.

IPOA - International Plan of Action

IRCS - International Radio Call Sign issued by the International Telecommunications Union

IMO - International Maritime Organization of the United Nations

IUU - Illegal, Unreported and Unregulated Fishing

Kort nozzle¹ – a propeller fitted with a non-rotating nozzle. It may be fixed, with directional control coming from a rudder set in the water flow, or pivoting, where their flow controls the vessel's steering.

Lazarette - A storage space in a boat's stern area.

Lee - The side sheltered from the wind.

Length overall¹ (**LOA**; also **o/a**, **o.a.** or **oa**) - the maximum length of a vessel from the two points on the hull most distant from each other, measured perpendicular to the waterline.

Line - Rope and cordage used aboard a vessel.

LOA – see length overall

Maximum Sustainable Yield³ (**MSY**) - The highest theoretical equilibrium yield that can be continuously taken (on average) from a stock under existing (average) environmental conditions without affecting significantly the reproduction process.

MCS - Monitoring, Control and Surveillance

MSY – see Maximum Sustainable Yield

Net drum³ – a wide powered spool (usually hydraulic) on which a trawl or salmon purse seine net is wound when hauling.

Net Register Tonnage¹ (**NRT**) is the volume of cargo the vessel can carry; ie. the Gross Register Tonnage less the volume of spaces that will not hold cargo (e.g. engine

compartment, helm station, crew spaces, etc., again with differences depending on which port or country is doing the calculations). No longer a standard measure.

Net tonnage¹ - (**NT**; also **N.T.**, **nt**) is a calculated representation of a the internal volume of a ship's cargo holds but has a different formula from Gross Register tonnage. It is expressed in "tons", which are units of volume defined as 100 cubic feet (~2.83 m³). The "ton" as a unit of volume should not be confused with the far more common "ton" as a unit of weight or mass.

NGO - Non-governmental Organization

NT – see net tonnage

NRT – see net register tonnage

Ortza⁴ -A metal triangle to which the end of the net is attached. A typical seine net tapers up gradually from its maximum depth (generally 12-18 strips) to the ortzas. The bow ortza is at the sack end of the net, while the stern ortza is at the end first hauled aboard during a set.

Outrigger¹ - part of a boat's rigging which is rigid and extends beyond the side of a boat.

Pair trawl – two vessels towing one net; may also be called the sweeping net in the Limbe area.

Pitch² –the theoretical distance a prop moves forward in one revolution.

Port - The left side of a boat looking forward. A harbor is also called a port.

Ports of Convenience (PoC) - Where a port State is unwilling or unable to exercise measures to combat IUU fishing activities, such as inspections to detect IUU-caught fish, and prohibitions on landing of illegal catches.

Port state measures - Through denial of access to ports, port inspections, prohibition of landing, and even detention or sanctions, port States can help prevent IUU catches from reaching international markets, an important disincentive to Illegal, Unreported and Unregulated (IUU) fishing.

Power block³ - a mechanized pulley used to haul in nets, purse seine, etc. Also referred to as a **Puretic power block** .

Pursing - the process of retrieving the purse cable in order to draw in and close the bottom of the net.

Radar¹ is an object detection system that uses electromagnetic waves (e.g., microwaves or radio waves) to identify the range, altitude, direction, or speed of both moving and fixed objects such as aircraft, ships, motor vehicles, weather formations, and terrain. The term *RADAR* was coined in 1941 as an acronym for *radio detection and ranging*.

REC - Regional Economic Communities

RFMO - Regional Fishery Management Organizations

RFB – Regional Fishery Bodies

RSW – Refrigerated sea water; also sometimes CSW.

Rudder - A vertical plate or board for steering a boat.

Sack (bunt) - a portion of the net that is used to concentrate the catch and raise it to the surface for loading. It is situated towards the bow end, and is constructed of heavier and stronger twine in order to withstand the weight of large catches.

SAR - Synthetic Aperture Radar

Screw - A boat's propeller.

Scuppers - Drain holes on deck, in the toe rail, or in bulwarks.

Single Side Band Radio (SSB) – Calling range can be thousands of kilometers.

Snood – see branchline

SOLAS - International Convention for the Safety of Life at Sea

Sonar¹ - (**sound navigation and ranging**) is a technique that uses sound propagation (usually underwater) to navigate, communicate with or detect other vessels or objects.

SRFC - Subregional Fisheries Commission (Northwest Africa)

SSB – see single side band

Starboard - The right side of a boat when looking forward.

Streamer line – Seabird mitigation device designed to deter birds from an area around the vessel, especially the stern.

Stern - The after part of the boat; opposite of bow.

Stock³ - A group of individuals in a species occupying a well defined spatial range independent of other stocks of the same species.

TAC - see Total Allowable Catch

Tail bag – see codend

TED – see Turtle excluder device

Tonnage¹ - a measure of the size or cargo capacity of a ship. There are a variety of measurements (see gross tonnage, gross register tonnage, net register tonnage and net tonnage).

Tori line – see Streamer line

Total Allowable Catch³ (TAC) - total catch allowed to be taken from a resource in a specified period (usually a year), as defined in the management plan.

Trawl³ – A cone or funnel-shaped net that is towed through the water by one or more vessels.

Trip – for the purposes of the CSOP, trip is defined as the period of time from when a vessel departs to go fishing and returns to a port (dock to dock).

Try net – a smaller, separate net towed by shrimp trawl vessels which is pulled for brief periods to test for shrimp concentrations or determine other fishing conditions

Turtle Excluder Device (TED) – is any modification to a shrimp trawl designed to reduce the capture of turtles. May also be referred to as a trawl efficiency device as the large animals may also be excluded.

Twin trawl – tow nets towed side by side (i.e., when shrimp trawler is towing 4 nets, there is a twin trawl off each outrigger)

Very Small Aperture Terminal (VSAT) – a two-way satellite ground station with a dish antenna that is smaller than 3 meters

Very High Frequency Radio (VHF) - The VHF band is divided into 71 channels with a frequency range of 156.000 to 163.000 MHz. Calling range is slightly more than line of sight.

Vessel monitoring systems¹ (VMS) are used in commercial fishing to allow environmental and fisheries regulatory organizations to monitor via satellite and in real time, the position, time at a position, and course and speed of fishing vessels (Flewwelling 2002).

VHF – see Very High Frequency

VMS - Vessel Monitoring System

VSAT – see Very Small Aperture Terminal

Winch¹ - a mechanical device that is used to pull in (wind up) or let out (wind out) or otherwise adjust the "tension" of a rope or wire rope (also called "cable" or "wire cable").

XBT – see expendable bathythermograph

¹Definition from *www.Wikipedia.org*

²<http://www.caravelleboats.com/propeller%20info.htm>

³ <http://www.fao.org/fi/glossary/>

⁴ IATTC definition